

dv/dt滤波器 (VTR) dv/dt Filter



产品概述 (Product Introduction)

PWM逆变器直接驱动电机时会产生较高dv/dt的共模电压,并由此产生轴承电流和共模漏电流以及严重的电磁干扰(EMI).特别是当逆变器通过长线电缆与电机连接时,由于电缆中分布参数的影响,会在电机端产生电压反射现象,从而在电机端会产生2倍以上的过电压,导致线圈绝缘失败.dv/dt滤波器降低电机电缆传输线效应电压的增大而衰减率,并最大限度地减少在电机端子上所发生的峰值电压。

When the PWM inverter will produce high common-mode voltage of dv/dt when directly driving the motor, resulting in bearing current and common-mode leakage current as well as severe electromagnetic interference (EMI). Especially when the inverter is connected to the motor with a long cable, the influence of the distribution parameters of the cable will result in voltage reflection, which will produce over-voltage of over two times at the motor terminal, causing failure of the coil insulation. However, dv/dt filters can reduce the rate of decay due to increase of the effect voltage during transmission of the motor cable, and minimize the peak voltage generated at the motor terminal.

产品应用 (Product Application)

dv/dt滤波器是设计用于保护电机的滤波器,由于变频器与电机之间运行电缆过长会引起对电机产生毁灭性影响峰值电压。电缆的长度取决于用在变频器中的电力半导体的开关次数和电机的大小,如果电缆短到2.5米则会导致电机承受的峰值电压超过电机绝缘系统的额定值。然而,如果电缆太长则问题更大,在这种情况下就需要用dv/dt滤波器来保护电机不受峰值电压的毁灭性影响。

The dv/dt filters are designed to protect the motor filter as peak voltage disastrous to the motor will be generated if the cable between the inverter and the motor is too long. The cable length depends on the switching times of the power semiconductor in the inverter and the size of the motor. A cable as short as 2.5m will result in peak voltage of the motor exceeding the rated value of the motor insulation system. However, the problem is even greater if the cable is too long, in which case you need to use a dv/dt filter to protect the motor from the devastating impact of the peak voltage.

技术规格 (Technical Specifications)

- 1.最大工作电压 Work Voltage: 400V AC-1140V AC
- 2.额定电流 Work Current: 5~500A
- 3.频率 Work Frequency: 50-60Hz
- 4.开关频率 Switching frequency: 2~8KHz
- 5.防护等级 Protection class: IP00-IP20
- 6.绝缘等级 Insulation Class: class F,H
- 7.使用环境: -10~+45 °C,额定值不会降低。最高可达+55°C,在45°C以上,每升高1°C,额定电流降低2%
Operation Environment:-10~+45 °C, rated value wont Up to+55 °C, above 45 °C, for every 1 °C increase, the rated current decreases by 2%
- 8.最大电缆长度 Maximum cable length: 1000m
- 9.最大电流 Max Current: 1.5×额定电流,持续60S 1.5 × Rated current,continuous 60S
- 10.噪音 Noise: ≤65dB
- 11.温升 Temperature Rise: ≤85K
- 12.抗电强度: 铁芯-绕组 3000VAC/50Hz/5mA/10s无飞弧击穿(工厂测试)
Dielectric strength: Core Coil 3000VAC/50Hz/5mA/10s no electric arcing puncture (factory test)
- 13.绝缘电阻 Insulation Resistor: 1000VDC insulation resistance value ≥ 100MΩ
- 14.海拔高度不超过2000米。Under seal level 2000m
- 15.运行环境温度-25°C~+45°C,相对湿度不超过90%。
Running ambient temperature -25 °C ~ +45 °C, comparative moisture not over 90%.
- 16.周围无有害气体,无易燃易爆物品。No hazardous gas,no inflammables and explosives
- 17.周围环境应有良好的通风条件,如装在柜内,应加装通风设备。
With well-ventilated condition,ventilation devices shall be mounted if installtioh in panels

典型电路图 (Typical circuit diagram)

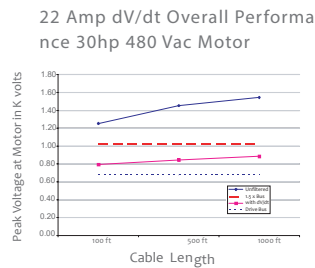
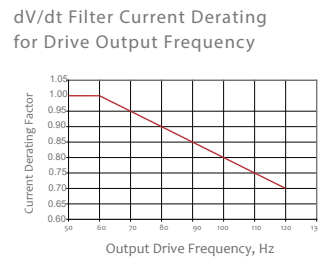
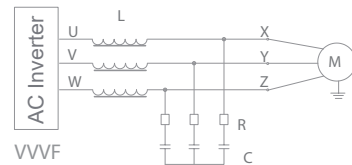

执行标准 (Applicable Standards)

IEC289: 1987 Reactor
GB10229-88 Reactor (eqvIEC289: 1987)
JB9644-1999 Reactors used for semiconductor electrical driving

1000 ft Full Load, 8kHz Switching, Unfiltered Shielded Cable

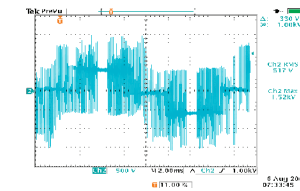

1000 ft Full Load, 8kHz Switching with dv/dt Filter

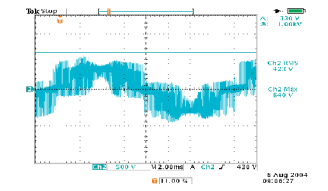

产品尺寸图 (Product Size)

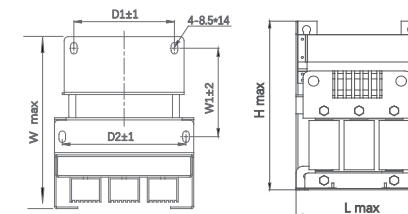

Picture A

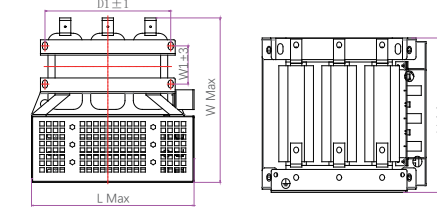

Picture B

380V 滤波器型号 TYPE	适配功率 Power(kw)	图号 Picture NO.	额定电流 Rated Current (A)	绝缘等级 Insulation Class	尺寸 Dimension(±5mm)						
					L(max)	W(max)	H(max)	W1±2	D1±2	D2±2	A*B
VTR-0005-0.4SC	2.2		5	F,H	200	235	270	68	55/95	160	8.5*14/6*15
VTR-0010-0.4SC	3.7-4.5		10	F,H	200	235	270	68	55/95	160	8.5*14/6*15
VTR-0015-0.4SC	5.5		15	F,H	200	240	270	104	130	160	8.5*14
VTR-0020-0.4SC	7.5		20	F,H	200	240	270	120	130	160	8.5*14
VTR-0030-0.4SA	11	图 A	30	F,H	240	240	320	115	150	200	8.5*14
VTR-0040-0.4SA	15	Picture A	40	F,H	240	250	320	135	150	200	8.5*14
VTR-0050-0.4SA	18.5		50	F,H	240	260	325	135	150	200	8.5*14
VTR-0060-0.4SA	22		60	F,H	240	260	330	143	150	200	8.5*14
VTR-0080-0.4SA-YT	30		80	F,H	355	370	255	73	245	245	11*18
VTR-0090-0.4SA-YT	37		90	F,H	355	370	255	73	245	245	11*18
VTR-0120-0.4SA-YT	45		120	F,H	390	385	230	83	280	280	11*18
VTR-0150-0.4SA-YT	55		150	F,H	390	400	285	103	280	280	11*18
VTR-0200-0.4SA-YT	75		200	F,H	390	385	285	87	280	280	11*18
VTR-0250-0.4SA-YT	90/110		250	F,H	370	385	300	87	280	280	11*18
VTR-0290-0.4SA-YT	132	图 B	290	F,H	370	385	300	87	280	280	11*18
VTR-0330-0.4SA-YT	160	Picture B	330	F,H	440	400	300	97	280	280	11*18
VTR-0390-0.4SA-YT	185		390	F,H	440	410	300	107	280	280	11*18
VTR-0490-0.4SA-YT	220/250		490	F,H	370	410	400	97	280	280	11*18

备注: 其他规格尺寸, 可根据用户要求制造。Remark: Dimension can be customization

成品识别码 (Product Identification Code)



690V滤波器型号 reactor Type	适配功率 Power (KW)	图号 Picture NO.	额定电流 Rated Current (A)	绝缘等级 Insulation Class	尺寸 Dimension					
					L(max)	W(max)	H(max)	W1±2	D±2	A*B
VTR-0080-0.7SA	75		80	F	330	290	410	200	280	11*18
VTR-0090-0.7SA	90		90	F	330	290	410	200	280	11*18
VTR-0120-0.7SA	110		120	F	380	340	400	250	330	11*18
VTR-0150-0.7SA	132		150	F	340	390	420	250	265	12*20
VTR-0215-0.7SA	160-200		215	F	340	390	450	250	265	12*20
VTR-0250-0.7SA	220		250	F	350	390	460	250	280	12*20
VTR-0330-0.7SA	250-300		330	F	350	400	500	250	280	12*20
VTR-0390-0.7SA	315-380	图B	390	F	370	390	480	250	300	12*20
VTR-0410-0.7SA	400		410	F	420	445	520	320	350	15*25
VTR-0490-0.7SA	450		575	F	460	445	520	320	390	15*25
VTR-0575-0.7SA	560		575	F	460	445	550	320	390	15*25
VTR-0810-0.7SA	710-800		810	F	510	485	560	320	430	15*25
VTR-1000-0.7SA	900-1000		1000	F						15*25
VTR-1200-0.7SA	1100-1200		1200	F						15*25
VTR-1400-0.7SA	1300-1400		1400	F						15*25

Cabinet structure 柜机结构

最大电缆长度 Maximum cable length: 300m内, 非屏蔽. Within 300m, unshielded

产品尺寸图 (Product Size)

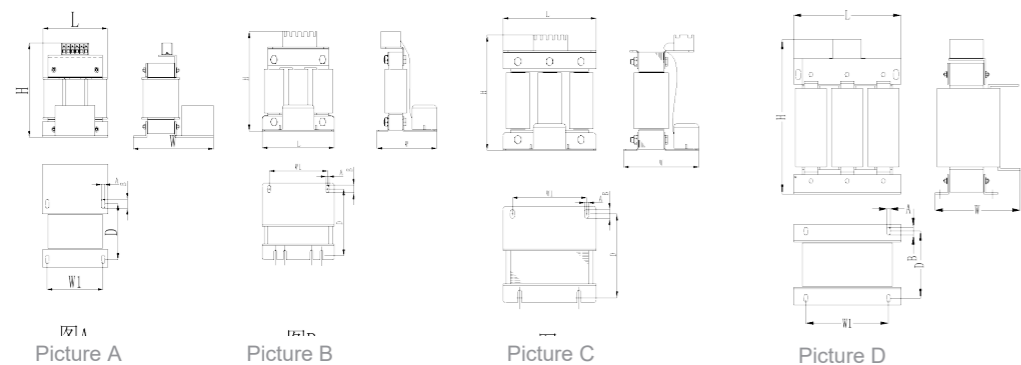

380-480VDUDT滤波器(T1) 380-480VDUDT Filter (T1)

型号 TYPE	材质 material	适配功率 Power(kw)	图号 Picture NO.	额定电流 Rated Current (A)	绝缘等级 Insulation Class	尺寸 Dimension(±5mm)						重量 weight
						L(max)	W(max)	H(max)	W1±2	D1±2	A*B	
VTR-0005-0.4SC(100)	CU铜线	1.1-1.5	图 A	5	F	110	130	130	90	70	6*11	2.3
VTR-0010-0.4SC(100)	CU铜线	2.2-4	Picture A	10	F	110	130	135	90	70	6*11	2.5
VTR-0020-0.4SC(100)	CU铜线	5.5-7.5		20	F	110	130	130	90	70	6*11	2.65
VTR-0030-0.4SC(100)	CU铜线	11	图 B	30	F	155	155	170	120	100	6*12	3.4
VTR-0040-0.4SC(100)	CU铜线	15	Picture B	40	F	155	155	170	120	100	6*12	3.6
VTR-0050-0.4SC(100)	CU铜线	15-22		50	F	155	165	170	120	110	6*12	5.2
VTR-0075-0.4SA(100)	AL线	30	图 C	75	F	190	165	205	150	130	8.5*14	8
VTR-0110-0.4SA(100)	AL线	37-45	Picture C	110	F	190	190	205	150	150	8.5*14	10
VTR-0200-0.4SA(100)	AL线	75-90		200	F	230	180	275	180	98	11*18	15
VTR-0250-0.4SA(100)	AL线	110		250	F	250	175	270	182	98	11*18	17
VTR-0330-0.4SA(100)	AL线	110-132	图 D	330	F	290	200	320	214	107	11*18	25
VTR-0390-0.4SA(100)	AL线	160-200	Picture D	390	F	290	200	315	214	107	11*18	30
VTR-0490-0.4SA(100)	AL线	250		490	F	290	200	315	214	107	11*18	35
VTR-0800-0.4SA(100)	AL线	315-400		800	F	320	250	385	243	140	11*18	55

最大电缆长度 Maximum cable length: 100m内, 非屏蔽. Within 100m, unshielded

备注: 其他规格尺寸, 可根据用户要求制造. Remark: Dimension can be customization

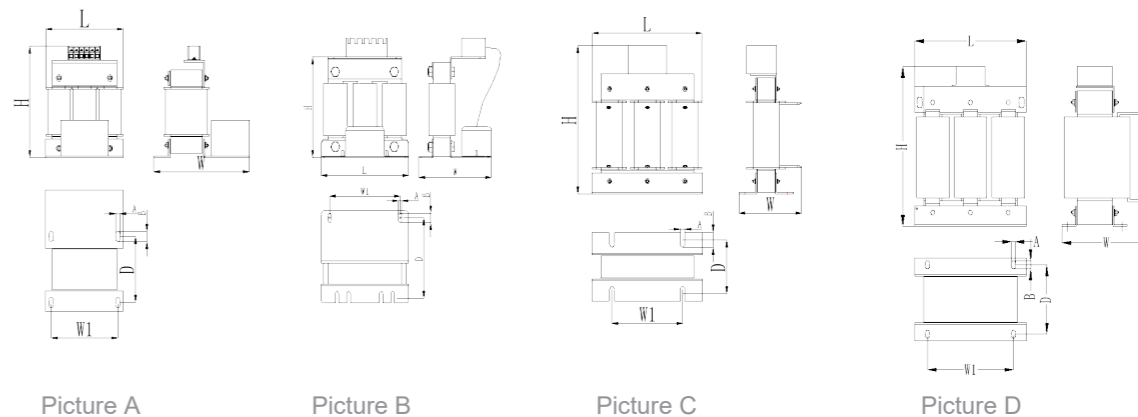

380-480VDUDT滤波器(T2) 380-480VDUDT Filter (T2)

型号 TYPE	材质 material	适配功率 Power(kw)	图号 Picture NO.	额定电流 Rated Current (A)	绝缘等级 Insulation Class	尺寸 Dimension(±5mm)						重量 weight
						L(max)	W(max)	H(max)	W1±2	D1±2	A*B	
VTR-0005-0.4SC (200)	CU铜线	2.2	图 A	5	F	110	140	130	90	70	6*11	3
VTR-0010-0.4SC (200)	CU铜线	3.7-4.5	Picture A	10	F	110	140	135	90	70	6*11	3.8
VTR-0015-0.4SC (200)	CU铜线	5.5	图 B	15	F	155	140	170	120	98	6*12	4.5
VTR-0020-0.4SC (200)	AL线	7.5	Picture B	20	F	155	140	170	120	98	6*12	4.5
VTR-0030-0.4SA (200)	AL线	11		30	F	195	140	220	120	70	8.5*20	10
VTR-0040-0.4SA (200)	AL线	15	图 C	40	F	195	140	220	120	70	8.5*20	10
VTR-0050-0.4SA (200)	AL线	18.5	Picture C	50	F	195	160	220	120	90	8.5*20	11
VTR-0060-0.4SA (200)	AL线	22		60	F	195	160	220	120	90	8.5*20	13
VTR-0080-0.4SA (200)	AL线	30		80	F	195	170	220	120	100	8.5*20	12
VTR-0090-0.4SA (200)	AL线	37		90	F	195	170	220	120	100	8.5*20	12
VTR-0120-0.4SA (200)	AL线	45		120	F	250	225	335	182	118	11*18	27
VTR-0150-0.4SA (200)	AL线	55		150	F	250	225	335	182	118	11*18	28.5
VTR-0200-0.4SA (200)	AL线	75		200	F	250	225	335	182	118	11*18	29.5
VTR-0250-0.4SA (200)	AL线	90/110	图 D	250	F	250	225	335	182	118	11*18	31
VTR-0290-0.4SA (200)	AL线	132		290	F	250	225	335	182	118	11*18	31
VTR-0330-0.4SA (200)	AL线	160	Picture D	330	F	320	210	385	243	114	11*18	38
VTR-0390-0.4SA (200)	AL线	185		390	F	320	230	385	243	134	11*18	38
VTR-0490-0.4SA (200)	AL线	220/250		490	F	320	250	385	243	154	11*18	63

最大电缆长度 Maximum cable length: 200m内, 非屏蔽. Within 200m, unshielded

备注: 其他规格尺寸, 可根据用户要求制造. Remark: Dimension can be customization