

谐波滤波器 (HFR) Harmonic Filter

产品概述 (Product Introduction)

谐波滤波器 (HFR) 包括主电感器L1和L2和电感器L3以及电容器C组合的二级吸收电路,单元可配装互感器TA以及支路接触器KM,吸收电路需要特别调整,可改善以第5次和第5次以上的谐波电流。基波频率50HZ和基波频率60HZ的电路是不同的基波频率。滤波器性能随负载功能的变化而变化。额定负载下, HFR滤波器的性能THDi ≤ 5%或 ≤ 10%

The harmonic filter (HFR) includes a secondary absorption circuit consisting of main inductor L1 and L2, inductor L3, and capacitor C combination. The unit can be equipped with transformer TA and branch contactor KM, and the absorption circuit needs special adjustment to improve the harmonic current of the 5th and above. The circuits with a fundamental frequency of 50Hz and 60Hz have different fundamental frequencies. The filter performance varies with the load function. Under rated load, the performance of HFR filter THDi ≤ 5% or ≤ 10%

产品应用 (Product Application)

适用于各种前端是六脉冲整流的电力设备将谐波电流减小到规定限值以下。

日常用电负载,非线性负载占很大一部分。Applicable to a variety of front-end is six-pulse rectifier power equipment harmonic current to reduce the specified limit below. DailyElectrical Load, nonlinear load accounts for a large part.

HFR谐波滤波器可以快速方便地将标准电机驱动升级为低谐波驱动。

The HFR harmonic filter can quickly and conveniently upgrade the standard motor drive to the low harmonic drive.

其典型应用有: Typical applications include:

- | | |
|---|--|
| <ul style="list-style-type: none"> ■ 配备前端六脉冲整流器的设备
Equipment equipped with a front-end six-pulse rectifier ■ AC和DC电动机驱动器
AC and DC motor drivers ■ 工厂自动化设备
Factory automation equipment ■ UPS及三相电源
UPS and three-phase power supply ■ 水/废水处理设施
Water/wastewater treatment facilities ■ 石油及天然气勘探
Oil and gas exploration | <ul style="list-style-type: none"> ■ 重工业及机械
Heavy industry and machinery ■ 自给式系统 (如船舶)
A self-contained system (as of a ship) ■ 风机及泵应用
Fan and pump applications ■ 电池充电器
Battery Charger ■ 供热通风与空调工程装置
Heating, ventilation and air conditioning engineering equipment ■ 关键工程
Key projects |
|---|--|

技术规格 (Technical Specifications)

额定工作电压 Rated working voltage	3×370 to 500VAC
电压容差范围 Voltage tolerance range	3×342 to 550VAC
工作频率 Operating frequency	50Hz/60Hz
电机驱动输入电流* Motor drives input current	10 to 500A@50° C
电机驱动输入功率 The motor drives the input power	4 to 315KW
总谐波电流畸变THID**	在额定功率下At rated power: THDi ≤ 5%/ ≤ 10%
效率 Efficiency	>98.5%
绝缘等级 Insulation grade	class F,H
抗电强度 Electrical strength	P=>E 2500VAC(1分钟)
防护等级 Protection level	IP00-IP20
冷却 Cooling	风冷 Air-cooled
过载容量 Overload capacity	1.5 * In / 60S
环境温度范围 Ambient temperature range	全操作状态 Full operational status: -25° C to +50° C 降容操作状态 Volume Reduction Operation Status: +50° C to +70° C*** 运输和存放 Transport and storage: -25° C to +85° C

* 谐波滤波器可以通过降低谐波电流和提高功率因数来降低有效输入和峰值电流。

The harmonic filter can reduce the effective input and peak current by reducing the harmonic current and increasing the power factor.

** 系统要求 System requirements: THDi < 2%, 线电压不平衡度 Line voltage unbalance < 1%.

*** Iderated=Inominal*√(85° C-Tamb) /35° C



* 谐波滤波器可以通过降低谐波电流和提高功率因数来降低有效输入和峰值电流。

The harmonic filter can reduce the effective input and peak current by reducing the harmonic current and increasing the power factor.

** 系统要求 System requirements: THDi < 2%, 线电压不平衡度 Line voltage unbalance < 1%.

*** Iderated=Inominal*√(85° C-Tamb) /35° C

对应负载时的THDi	HFR010	HFR005
40%负载	~12%	~7%
70%负载	~11%	~6%
100%负载	<10%	<5
100%负载下的效率*	>98.5%	
真实功率因数*		
40%负载	~81%	~80%
70%负载	~96%	~95%
100%负载	>99%	>98%
冷却	自冷/风冷	

谐波的影响很严重

谐波会降低系统效率,浪费宝贵的能量。谐波电流会导致电力装置、配电变压器、断路器、熔断器、导线等出现过载和过热。它们会使系统提前老化,或者需要增加电力系统的容量。谐波会使VAR补偿设备中的电容器组过载,并导致电子控制器出现故障,敏感医疗设备受到干扰,或者通信网络崩溃。

经济后果

很不幸,降低谐波需要付出较高的成本。在很多情况下,在项目规划阶段的预算中都不会考虑此成本。不过,如果忽视这个问题,可能需要为此付出多得多成本。可能需要增加电力设施的容量。设备可能会提前失效。在出现干扰的情况下可能会导致生产停产。电力公司甚至可能会开出违反电力质量要求的罚单,导致整个工厂必须临时从电网断开。

简单的即插即用操作

HFR滤波器为箱体结构,共有3个输入和3个输出接头。它们可以方便地集成到已有设计方案中,不需要进行深入系统分析,也不需要非常专业的人员操作。HFR滤波器不会从系统其它元器件吸收谐波,也不会导致系统共振。它们可以与安装在同一系统内的直流母线扼流圈以及EMC/EMI滤波器实现平滑操作。

因为采用了出色的电感器设计方案和先进的热控制方法,所以产品是市场上结构最紧凑的滤波器。传统的谐波抑制方法需要采用大型的单体机柜,而HFR体积小,重量轻,可以将滤波器方便地直接集成在电动机传动旁边的电气柜中。

增加设备寿命,保证可靠的生产运行时间

因为HFR滤波器采用了独特的设计,所以可以增加电源的阻抗,从而实现传统交流输入电抗器所有优点。比如,在电动机传动应用中,它们可以消除干扰跳闸,保护整流器和直流母线电容不受市电瞬变电流的影响。通过增加设备使用寿命并保证关键应用的可靠操作功能,可以降低成本并为利润提供保障。

在谐波源头(也就是在各非线性负载处)将其消除是最好的控制方式。只有这样,才能避免谐波电流和电压在整个系统中传播。HFR滤波器采用了独特的设计来解决这个问题,它们针对整流器所需的谐波电流采用了一个低阻抗,从而显著降低了流经配电系统的谐波。这样,非线性负载从电网吸收的电流基本都是正弦电流。

总谐波电流失真率和负荷率曲线

Total harmonic current distortion rate and load rate curve

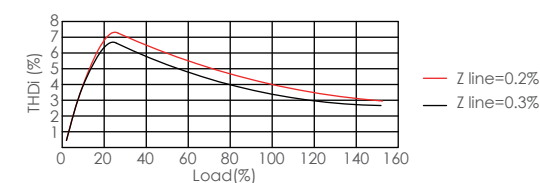

当负载负荷大于70%时,能将电流谐波THDi降到大约5%以下
全功率范围内能将电流谐波失真率THDi抑制在8%以内

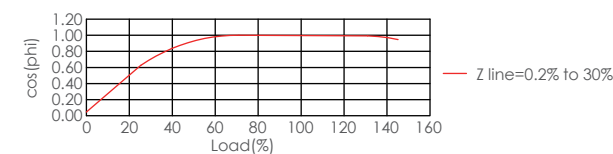

大功率变频器有直流电抗器时,额定功率下,能将电流谐波THDi降到5%以下
大功率变频器有直流电抗器时,全功率范围内,能将电流谐波THDi降到15%以下

变频器直流母线电压

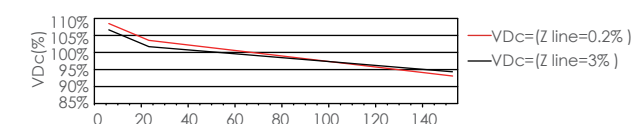

负载轻载时,变频器直流母线电压不超过110%
额定功率时,变频器直流母线电压不低于93%

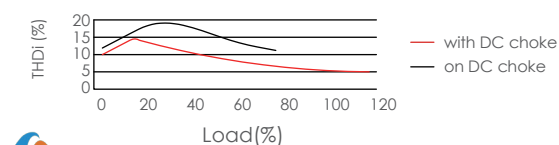

负载轻载时,大功率变频器直流母线电压不超过105%
额定功率时,大功率变频器直流母线电压不低于96%

实现高性能

在很多情况下，制造商只提高全负载条件下的滤波器性能，因为小负载条件下在降低谐波和处理电容电流方面存在困难。HFR滤波器不仅能保证在整个负载范围内的总谐波电流畸变率，而且还能限制所有条件下的电容电流值。

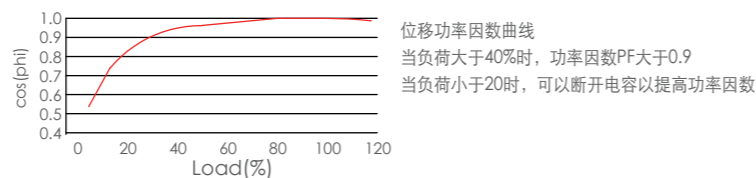

标准滤波器应用于不同行业的各种电网，用户可以选择多种功率，电流，电压和频率规格，因而能够选择最适合的滤波器。当然，用户可能还会有其他电气或机械要求，或者除了产品之外还需要其他服务。

拥有独特优势，能够帮助用户分析问题，提出工程建议，提供测试和测量支持，定制化产品。我们的目标是保证满足您的实际谐波抑制需求。

典型电路图

Typical circuit diagram

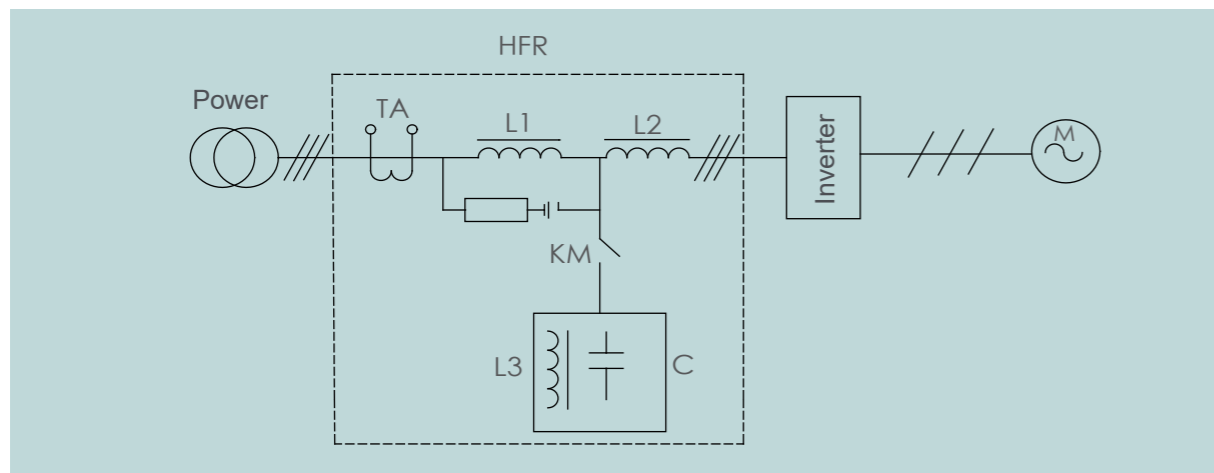

执行标准 (Applicable Standards)

EN61558-2-20
CE(LVD 2006/95/EC)

电气数据 (Electrical data)

无源系列类别目录 Passive series category catalog

电压系统 (V) ±10%	频率 (Hz)	总谐波电流失真 THID	IP 等级	功率范围 (kW)	效率	冷却方式	过载能力	产品无故障时间 MTBF	电流总需求量畸变系数 TDD	环境温度范围	短路电流额定值 SCCR	接地系统	超电压类别
380-415	50±1Hz	≤5% @额定功率	IP20	2.2	>98%	AN	1.6 倍额定电流 可维持 1 分钟 每小时一次	>200,000 小时	根据 IEEE-519 标准	-25°C到+45°C 可正常运行 +45°C到+70°C 需要降低额定值	100 kA	TN, TT, IT	OV III (IEC 60664-1 / UL 61800-5-1)
	50±1Hz	≤5% @额定功率	IP00										
	50±1Hz	≤10% @额定功率	IP20										
	50±1Hz	≤10% @额定功率	IP20										
440-500	50±1Hz	≤5% @额定功率	IP20	315	>98%	AN	1.6 倍额定电流 可维持 1 分钟 每小时一次	>200,000 小时	根据 IEEE-519 标准	-25°C到+85°C 运输和储藏	100 kA	TN, TT, IT	OV III (IEC 60664-1 / UL 61800-5-1)
	50±1Hz	≤5% @额定功率	IP00										
	50±1Hz	≤10% @额定功率	IP20										
	50±1Hz	≤10% @额定功率	IP20										
电压系统 (V) ±10%	频率 (Hz)	总谐波电流失真 THID	IP 等级	标称电机驱动输入功率额定值	效率	冷却方式	过载能力	产品无故障时间 MTBF	电流总需求量畸变系数 TDD	环境温度范围	短路电流额定值 SCCR	接地系统	超电压类别
380-415	60±1Hz	≤5% @额定功率	IP20	1	>98%	AN	1.6 倍额定电流 可维持 1 分钟 每小时一次	>200,000 小时	根据 IEEE-519 标准	-25°C到+45°C 可正常运行 +45°C到+70°C 需要降低额定值	100 kA	TN, TT, IT	OV III (IEC 60664-1 / UL 61800-5-1)
	60±1Hz	≤5% @额定功率	IP00										
	60±1Hz	≤10% @额定功率	IP20										
	60±1Hz	≤10% @额定功率	IP20										
440-500	60±1Hz	≤5% @额定功率	IP20	240	>98%	AN	1.6 倍额定电流 可维持 1 分钟 每小时一次	>200,000 小时	根据 IEEE-519 标准	-25°C到+85°C 运输和储藏	100 kA	TN, TT, IT	OV III (IEC 60664-1 / UL 61800-5-1)
	60±1Hz	≤5% @额定功率	IP00										
	60±1Hz	≤10% @额定功率	IP20										
	60±1Hz	≤10% @额定功率	IP20										

* 系统要求: THVD <2%, 线电压不平衡 <1%

说明: 本手册提供的性能规格参考的是 6 脉冲二极管整流器。

可控硅整流器的前端可能产生不同结果，取决于晶闸管流管的发射角。

THID~5% (在额定功率下，针对 <6 kW 的滤波器)

** 请参阅数据表，了解冷却所要求的进气空气流量

*** I derated = Inominal * (Tmax-Tamb)/(Tmax-Tnominal) = Inom * (70°C-Tamb)/25°C

**** 需要在外部增加 UL 级保险丝。请参阅用户手册

*System requirements: THVD<2%, line voltage imbalance<1%

Explanation: The performance specifications provided in this manual refer to a 6-pulse diode rectifier.

The front-end of a thyristor rectifier may produce different results depending on the emission angle of the thyristor.

THID~5% (at rated power, for filters<6 kW)

**Please refer to the data sheet for the required intake air flow rate for cooling

*** I derated = Inominal * (Tmax-Tamb)/(Tmax-Tnominal) = Inom * (70°C-Tamb)/25°C

****We need to add UL grade fuses externally. Please refer to the user manual

成品识别码 (Product Identification Code)

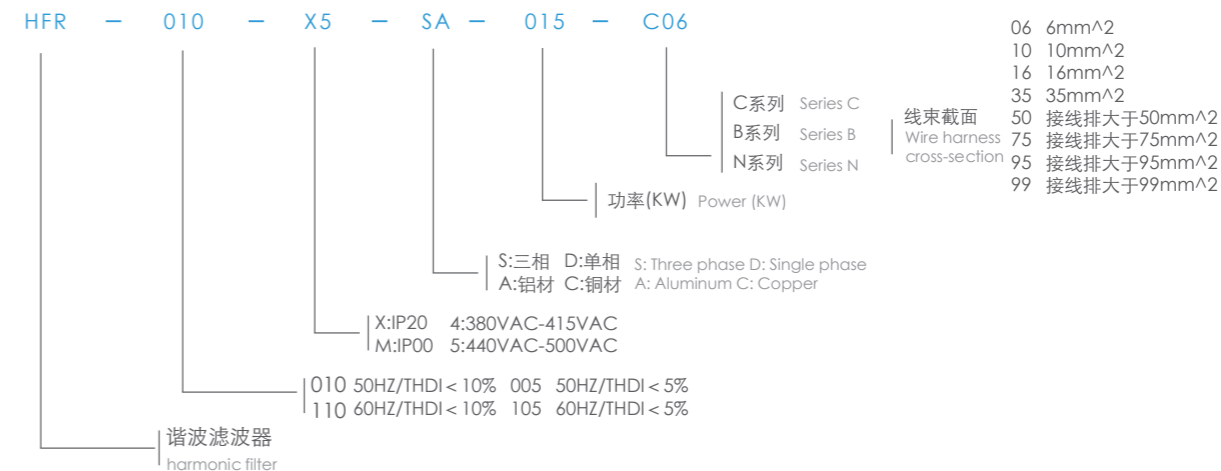

谐波滤波器C系列 380-415V-50Hz-5%-IP20 Harmonic filter C series 380-415V-50Hz-5%-IP20

谐波滤波器型号 Harmonic filter type	额定负荷功率 [kW] Rated load power	电机驱动输入电流 [Arms] Motor drive input current	额定滤波器输入电流 [Arms] Rated filter input current	净重 [kg] Net weight	毛重 [kg] Gross weight	典型损耗 [W] Typical loss	适配电缆 [m²] Adapter cable	机型 model
HFR005X4SC001C06	0.4-1.5	1-3.7	0.5-2.2	10	17.5	29.5	06	H1
HFR005X4SC002C06	2.2	5.5	3.28	14.5	21.75	45	06	H1
HFR005X4SC005C06	3.7-5.5	10-13	8.2	20	30	75	06	H1
HFR005X4SC007C06	7.5	16	11.2	26	39	100	06	H1
HFR005X4SA011C10	11	24	16.5	35	52.5	125	10	H1
HFR005X4SA015C10	15	30	22.5	45	67.5	225	10	H2
HFR005X4SA022C16	18.5-22	44	32.5	52	78	300	16	H2
HFR005X4SA030C16	30	60	44.5	63	94.5	360	16	H3
HFR005X4SA037C35	37	75	54.8	70	105	420	35	H3
HFR005X4SA045C35	45	90	66.8	88	132	470	35	H3
HFR005X4SA055C50	55	110	81.8	103	154.5	560	50	H3
HFR005X4SA075C99	75	150	111	118	177	750	99	H4
HFR005X4SA090C99	90	180	134	135	202.5	850	99	H4
HFR005X4SA110C99	110	210	164	158	237	950	99	H4
HFR005X4SA132C99	132	260	197	245.8	318.7	1050	99	H5
HFR005X4SA160C99	160	320	240	328.5	492.75	1300	99	H5

谐波滤波器C系列 380-415V-50Hz-5%-IP00 Harmonic filter C series 380-415V-50Hz-5%-IP00

谐波滤波器 型号 Harmonic filter type	额定负荷功率 [kW] Rated load power	电机驱动输入 电流 [Arms] Motor drive input current	额定滤波器输入 电流[Arms] Rated filter input current	重量 [kg] weight	毛重 [kg] Gross weight	典型损耗 [W] Typical loss	适配电缆 [m ²] Adapter cable	机型 model
HFR005M4SA075C99	75	150	111	118	177	750	99	H6
HFR005M4SA090C99	90	180	134	135	202.5	850	99	H6
HFR005M4SA110C99	110	210	164	158	237	950	99	H6
HFR005M4SA132C99	132	260	197	245.8	318.7	1050	99	H7
HFR005M4SA160C99	160	320	240	328.5	492.75	1300	99	H7
HFR005M4SA200C99	185-200	400	296	373	559.5	1500	99	H8
HFR005M4SA250C99	220-250	480	356	418.5	627.75	1750	99	H9
HFR005M4SA315C99	285-315	600	444	450	675	2150	99	H10
HFR005M4SA355C99	355	670	500	500	750	2350	99	H11

谐波滤波器C系列 380-415V-50Hz-10%-IP20 Harmonic filter C series 380-415V-50Hz-10%-IP20

谐波滤波器 型号 Harmonic filter type	额定负荷功率 [kW] Rated load power	电机驱动输入 电流 [Arms] Motor drive input current	额定滤波器输入 电流[Arms] Rated filter input current	重量 [kg] weight	毛重 [kg] Gross weight	典型损耗 [W] Typical loss	适配电缆 [m ²] Adapter cable	机型 model
HFR010X4SC001C06	0.4-1.5	1-3.7	0.5-2.2	10	17.5	29.5	06	H1
HFR010X4SC002C06	2.2	5.5	3.28	13	19.5	40.5	06	H1
HFR010X4SC005C06	3.7-5.5	10-13	8.2	18	27	67.5	06	H1
HFR010X4SC007C06	7.5	16	11.2	23.4	35.1	90	06	H1
HFR010X4SA011C10	11	24	16.5	31.5	47.25	112.5	10	H1
HFR010X4SA015C10	15	30	22.5	40.5	60.75	202.5	10	H2
HFR010X4SA022C16	18.5-22	44	32.5	46.8	70.2	270	16	H2
HFR010X4SA030C16	30	60	44.5	56.7	85.05	324	16	H3
HFR010X4SA037C35	37	75	54.8	63	94.5	378	35	H3
HFR010X4SA045C35	45	90	66.8	79.2	118.8	423	35	H3
HFR010X4SA055C50	55	110	81.8	92.7	139.05	504	50	H3
HFR010X4SA075C99	75	150	111	106.2	159.3	675	99	H4
HFR010X4SA090C99	90	180	134	135	202.5	765	99	H4
HFR010X4SA110C99	110	210	164	142.3	213.45	855	99	H4
HFR010X4SA132C99	132	260	197	245.8	318.7	1050	99	H5
HFR010X4SA160C99	160	320	240	328.5	492.75	1300	99	H5

谐波滤波器C系列 380-415V-50Hz-10%-IP00 Harmonic filter C series 380-415V-50Hz-10%-IP00

谐波滤波器 型号 Harmonic filter type	额定负荷功率 [kW] Rated load power	电机驱动输入 电流 [Arms] Motor drive input current	额定滤波器输入 电流[Arms] Rated filter input current	净重 [kg] Net weight	毛重 [kg] Gross weight	典型损耗 [W] Typical loss	适配电缆 [m ²] Adapter cable	机型 model
HFR010M4SA075C99	75	150	111	106.2	159.3	675	99	H6
HFR010M4SA090C99	90	180	134	135	202.5	765	99	H6
HFR010M4SA110C99	110	210	164	142.3	213.45	855	99	H6
HFR010M4SA132C99	132	260	197	245.8	318.7	1050	99	H7
HFR010M4SA160C99	160	320	240	328.5	492.75	1300	99	H7
HFR010M4SA200C99	185-200	400	296	373	559.5	1500	99	H8
HFR010M4SA250C99	220-250	480	356	418.5	627.75	1750	99	H9
HFR010M4SA315C99	285-315	600	444	450	675	2150	99	H10
HFR010M4SA355C99	355	670	500	500	750	2350	99	H11

谐波滤波器C系列 440-500V-50Hz-5%-IP20 Harmonic filter C series 440-500V-50Hz-5%-IP20

谐波滤波器 型号 Harmonic filter type	额定负荷功率@ [kW] Rated load power	净重 [kg] Net weight	毛重 [kg] Gross weight	典型损耗 @25°C/50Hz [W] Typical loss	适配电缆 [m ²] Adapter cable	机型 model
HFR005X5SC001C06	0.4-1.5	10	17.5	29.5	06	H1
HFR005X5SC002C06	2.2	14.5	21.75	45	06	H1
HFR005X5SC004C06	3.7	18.5	27.75	68	06	H1
HFR005X5SC005C06	5.5	20	30	75	06	H1
HFR005X5SC007C06	7.5	26	39	100	06	H1
HFR005X5SA011C06	11	35	52.5	125	06	H1
HFR005X5SA015C06	15	45	67.5	225	06	H2
HFR005X5SA022C10	18.5-22	52	78	300	10	H2
HFR005X5SA030C10	30	63	94.5	360	10	H3
HFR005X5SA037C10	37	70	105	420	10	H3
HFR005X5SA045C16	45	88	132	470	16	H3
HFR005X5SA055C35	55	103	154.5	560	35	H3
HFR005X5SA075C35	75	118	177	750	35	H4
HFR005X5SA090C50	90	135	202.5	850	50	H4
HFR005X5SA110C50	110	158	237	950	50	H4
HFR005X5SA132C75	132	245.8	318.7	1050	75	H5
HFR005X5SA160C95	160	328.5	492.75	1300	95	H5

谐波滤波器C系列 440-500V-50Hz-5%-IP00 Harmonic filter C series 440-500V-50Hz-5%-IP00

谐波滤波器 型号 Harmonic filter type	额定负荷功率@ [kW] Rated load power	净重 [kg] Net weight	毛重 [kg] Gross weight	典型损耗 @25°C/50Hz [W] Typical loss	适配电缆 [m ²] Adapter cable	机型 model
HFR005M5SA075C35	75	118	177	750	35	H6
HFR005M5SA090C50	90	135	202.5	850	50	H6
HFR005M5SA110C50	110	158	237	950	50	H6
HFR005M5SA132C75	132	245.8	318.7	1050	75	H7
HFR005M5SA160C95	160	328.5	492.75	1300	95	H7
HFR005M5SA200C99	185-200	373	559.5	1500	99	H8
HFR005M5SA250C99	220-250	418.5	627.75	1750	99	H9
HFR005M5SA315C99	285-315	480	720	2000	99	H10
HFR005M5SA355C99	355-385	520	780	2500	99	H11

谐波滤波器C系列 440-500V-50Hz-10%-IP00 Harmonic filter C series 440-500V-50Hz-10%-IP00

谐波滤波器 型号 Harmonic filter type	额定负荷功率@ [kW] Rated load power	净重 [kg] Net weight	毛重 [kg] Gross weight	典型损耗 @25°C/50Hz [W] Typical loss	适配电缆 [m ²] Adapter cable	机型 model
HFR010M5SA075C35	75	106.2	159.3	675	35	H6
HFR010M5SA090C50	90	12.5	18.75	765	50	H6
HFR010M5SA110C50	110	142.3	213.45	855	50	H6
HFR010M5SA132C75	132	145.8	218.7	1050	75	H7
HFR010M5SA160C95	160	328.5	492.75	1300	95	H7
HFR010M5SA200C99	185-200	373	559.5	1500	99	H8
HFR010M5SA250C99	220-250	418.5	627.75	1750	99	H9
HFR010M5SA315C99	285-315	480	720	2000	99	H10
HFR010M5SA355C99	355-385	520	780	2500	99	H11

谐波滤波器C系列 380-415V-60Hz-5%-IP20 Harmonic filter C series 380-415V-60Hz-5%-IP20

谐波滤波器型号 Harmonic filter type	额定负荷功率 Rated load power [KW]	电机驱动输入 电流[Arms] Motor drive input current	额定滤波器输入 电流[Arms] Rated filter input current	净重 [kg] Net weight	毛重 [kg] Gross weight	典型损耗 [W] Typical loss	适配电缆 [m ²] Adapter cable	机型 model
HFR105X4SC001C06	0.4-1.5	1-3.7	0.5-2.2	10	17	29.5	06	H1
HFR105X4SC002C06	2.2	7	5	14.5	21.75	88	06	H1
HFR105X4SC005C06	3.7-5.5	14	10.5	20	30	115	06	H1
HFR105X4SC007C06	7.5	21	14.4	26	39	185	06	H1
HFR105X4SA011C10	11	27-34	12	35	52.5	225	10	H1
HFR105X4SA015C10	15	44	29	45	67.5	285	10	H2
HFR105X4SA022C16	22	52-66	40	52	78	300	16	H2
HFR105X4SA030C16	30	83	55	63	94.5	450	16	H3
HFR105X4SA037C35	37	103	66	70	105	650	35	H3
HFR105X4SA055C50	55	128	96	103	154.5	850	50	H3
HFR105X4SA075C99	75	165	150	118	177	950	99	H4
HFR105X4SA090C99	90	208	180	135	202.5	1050	99	H4
HFR105X4SA110C99	110	240	217	158	237	1250	99	H4
HFR105X4SA132C99	132	320	259	205	315	1380	99	H5
HFR105X4SA160C99	160	403	290	265	397.5	1540	99	H5

谐波滤波器C系列 380-415V-60Hz-5%-IP00 Harmonic filter C series 380-415V-60Hz-5%-IP00

谐波滤波器型号 Harmonic filter type	额定负荷功率 Rated load power [KW]	电机驱动输入 电流[Arms] Motor drive input current	额定滤波器输入 电流[Arms] Rated filter input current	净重 [kg] Net weight	毛重 [kg] Gross weight	典型损耗 [W] Typical loss	适配电缆 [m ²] Adapter cable	机型 model
HFR105M4SA075C99	75	165	150	118	177	950	99	H6
HFR105M4SA090C99	90	208	180	135	202.5	1050	99	H6
HFR105M4SA110C99	110	240	217	158	237	1250	99	H6
HFR105M4SA132C99	132	320	259	205	315	1380	99	H7
HFR105M4SA160C99	160	403	290	265	397.5	1540	99	H7
HFR105M4SA200C99	200	495	370	305	457.5	1817	99	H8
HFR105M4SA250C99	250	610	520	350	525	2144	99	H9
HFR105M4SA315C99	315	759	580	403	604.5	2530	99	H10
HFR105M4SA355C99	355	820	650	425	637.5	2850	99	H11

谐波滤波器C系列 380-415V-60Hz-10%-IP20 Harmonic filter C series 380-415V-60Hz-10%-IP20

谐波滤波器型号 Harmonic filter type	额定负荷功率 Rated load power [KW]	电机驱动输入 电流[Arms] Motor drive input current	额定滤波器输入 电流[Arms] Rated filter input current	净重 [kg] Net weight	毛重 [kg] Gross weight	典型损耗 [W] Typical loss	适配电缆 [m ²] Adapter cable	机型 model
HFR110X4SC001C06	0.4-1.5	1-3.7	0.5-2.2	10	17	29.5	06	H1
HFR110X4SC002C06	2.2	7	5	12.5	18.75	80	06	H1
HFR110X4SC005C06	3.7-5.5	14	10.5	18	27	105	06	H1
HFR110X4SC007C06	7.5	21	14.4	23.5	35.25	172	06	H1
HFR110X4SA011C10	11	27-34	12	32	48	210	10	H1
HFR110X4SA015C10	15	44	29	41.5	62.25	255	10	H2
HFR110X4SA022C16	22	52-66	40	48.5	72.75	280	16	H2
HFR110X4SA030C16	30	83	55	59	88.5	395	16	H3
HFR110X4SA037C35	37	103	66	65	97.5	580	35	H3
HFR110X4SA055C50	55	128	96	96	144	760	50	H3
HFR110X4SA075C99	75	165	150	108	162	880	99	H4
HFR110X4SA090C99	90	208	180	118	177	965	99	H4
HFR110X4SA110C99	110	240	217	142	213	1050	99	H4
HFR110X4SA132C99	132	320	259	150	225	1380	99	H5
HFR110X4SA160C99	160	403	290	265	397.5	1540	99	H5

谐波滤波器C系列 380-415V-60Hz-10%-IP00 Harmonic filter C series 380-415V-60Hz-10%-IP00

谐波滤波器型号 Harmonic filter type	额定负荷功率 Rated load power [KW]	电机驱动输入 电流[Arms] Motor drive input current	额定滤波器输入 电流[Arms] Rated filter input current	净重 [kg] Net weight	毛重 [kg] Gross weight	典型损耗 [W] Typical loss	适配电缆 [m ²] Adapter cable	机型 model
HFR110M4SA075C99	75	165	150	108	162	880	99	H6
HFR110M4SA090C99	90	208	180	118	177	965	99	H6
HFR110M4SA110C99	110	240	217	142	213	1050	99	H6
HFR110M4SA132C99	132	320	259	150	225	1380	99	H7
HFR110M4SA160C99	160	403	290	265	397.5	1540	99	H7
HFR110M4SA200C99	200	495	370	305	457.5	1817	99	H8
HFR110M4SA250C99	250	610	520	350	525	2144	99	H9
HFR110M4SA315C99	315	759	580	403	604.5	2530	99	H10
HFR110M4SA355C99	355	820	650	425	637.5	2850	99	H11

谐波滤波器C系列 440-500V-60Hz-5%-IP20 Harmonic filter C series 440-500V-60Hz-5%-IP20

谐波滤波器型号 Harmonic filter type	额定负荷功率 Rated load power [KW]	电机驱动输入 电流[Arms] Motor drive input current	额定滤波器输入 电流[Arms] Rated filter input current	净重 [kg] Net weight	毛重 [kg] Gross weight	典型损耗 [W] Typical loss	适配电缆 [m ²] Adapter cable	机型 model
HFR105X5SC001C06	0.4-1.5	1-3.7	0.5-2.2	10	17	29.5	06	H1
HFR105X5SC002C06	2.2	7	5	14.5	21.75	88	06	H1
HFR105X5SC005C06	3.7-5.5	14	10.5	20	30	115	06	H1
HFR105X5SC007C06	7.5	21	14.4	23	36	165	06	H1
HFR105X5SC011C06	11	27-34	12	26	39	185	06	H1
HFR105X5SC015C06	15	44	29	35	52.5	225	06	H2
HFR105X5SA022C06	22	52-66	40	45	67.5	285	06	H2
HFR105X5SA030C10	30	83	55	52	78	300	10	H3
HFR105X5SA037C10	37	103	66	63	94.5	450	10	H3
HFR105X5SA045C16	45	115	80	70	105	650	16	H3
HFR105X5SA055C35	55	128	96	103	154.5	850	35	H4
HFR105X5SA075C35	75	165	150	118	177	950	35	H4
HFR105X5SA090C50	90	208	180	135	202.5	1050	50	H4
HFR105X5SA110C50	110	240	217	139	208.5	1050	50	H4
HFR105X5SA132C75	132	320	259	175	262.5	1380	75	H5
HFR105X5SA160C95	160	403	290	230	345	1540	95	H5

谐波滤波器C系列 440-500V-60Hz-5%-IP00 Harmonic filter C series 440-500V-60Hz-5%-IP00

谐波滤波器型号 Harmonic filter type	额定负荷功率@ Rated load power [KW]	电机驱动输入 电流[Arms] Motor drive input current	额定滤波器输入 电流[Arms] Rated filter input current	净重 [kg] Net weight	毛重 [kg] Gross weight	典型损耗 [W] Typical loss	适配电缆 [m ²] Adapter cable	机型 model
HFR105M5SA075C35	75	165	150	118	177	950	35	H6
HFR105M5SA090C35	90	208	180	135	202.5	1050	35	H6
HFR105M5SA110C75	110	240	217	139	208.5	1050	75	H6
HFR105M5SA132C75	132	320	259	175	262.5	1380	75	H7
HFR105M5SA160C95	160	403	290	230	345	1540	95	H7
HFR105M5SA200C99	200	495	370	260	390	1817	99	H8
HFR105M5SA250C99	250	610	520	315	472.5	2144	99	H9
HFR105M5SA315C99	315	759	580	345	517.5	2530	99	H10
HFR105M5SA355C99	355	820	650	385	577.5	2950	99	H11

谐波滤波器C系列 440-500V-60Hz-10%-IP20 Harmonic filter C series 440-500V-60Hz-10%-IP20

谐波滤波器型号 Harmonic filter type	额定负荷功率@ Rated load power [KW]	电机驱动输入 电流[A rms] Motor drive input current	额定滤波器输入 电流[A rms] Rated filter input current	净重 [kg] Net weight	毛重 [kg] Gross weight	典型损耗 [W] Typical loss	适配电缆 [mm²] Adapter cable	机型 model
HFR110X5SC001C06	0.4-1.5	1-3.7	0.5-2.2	10	17	29.5	06	H1
HFR110X5SC004C06	2.2	7	5	14.5	21.75	88	06	H1
HFR110X5SC005C06	3.7-5.5	14	10.5	20	30	115	06	H1
HFR110X5SC007C06	7.5	21	14.4	26	39	135	06	H1
HFR110X5SC011C06	11	27-34	12	28.5	43.75	165	06	H1
HFR110X5SC015C06	15	44	29	32.5	48.75	108	06	H2
HFR110X5SA022C06	22	52-66	40	41	61.5	162	06	H2
HFR110X5SA030C06	30	83	55	47.5	71.25	275	06	H3
HFR110X5SA037C10	37	103	66	58.5	87.75	415	10	H3
HFR110X5SA045C10	45	115	80	66	99	620	10	H3
HFR110X5SA055C10	55	128	96	95	142.5	815	10	H4
HFR110X5SA075C35	75	165	150	106	159	905	35	H4
HFR110X5SA090C50	90	208	180	118	177	980	50	H4
HFR110X5SA110C50	110	240	217	139	208.5	1050	50	H4
HFR110X5SA132C75	132	320	259	175	262.5	1380	75	H5
HFR110X5SA160C95	160	403	290	230	345	1540	95	H5

谐波滤波器C系列 440-500V-60Hz-10%-IP00 Harmonic filter C series 440-500V-60Hz-10%-IP00

谐波滤波器型号 Harmonic filter type	额定负荷功率 Rated load power [KW]	电机驱动输入 电流[A rms] Motor drive input current	额定滤波器输入 电流[A rms] Rated filter input current	净重 [kg] Net weight	毛重 [kg] Gross weight	典型损耗 [W] Typical loss	适配电缆 [mm²] Adapter cable	机型 model
HFR110M5SA075C35	75	165	150	106	159	905	35	H6
HFR110M5SA090C50	90	208	180	118	177	980	50	H6
HFR110M5SA110C50	110	240	217	139	208.5	1050	50	H6
HFR110M5SA132C75	132	320	259	175	262.5	1380	75	H7
HFR110M5SA160C95	160	403	290	230	345	1540	95	H7
HFR110M5SA200C99	200	495	370	260	390	1817	99	H8
HFR110M5SA250C99	250	610	520	315	472.5	2144	99	H9
HFR110M5SA315C99	315	759	580	345	517.5	2530	99	H10
HFR110M5SA355C99	355	820	650	385	577.5	2950	99	H11

产品尺寸图 (Product Dimension Drawing)

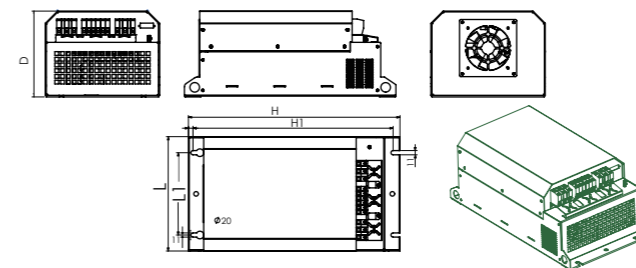

H1/H2/H3

机型 model	尺寸Size (±2mm)					
	L	D	H	L1	H1	A/B
H1	300	230	555	216	525	11*18
H2	410	275	650	350	640	11*15
H3	410	380	700	350	660	11*15

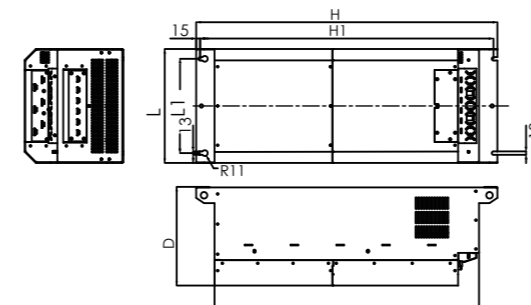

H4

机型 model	尺寸Size (±2mm)					
	L	D	H	L1	H1	A/B
H4	435	377	1150	360	1120	13*20

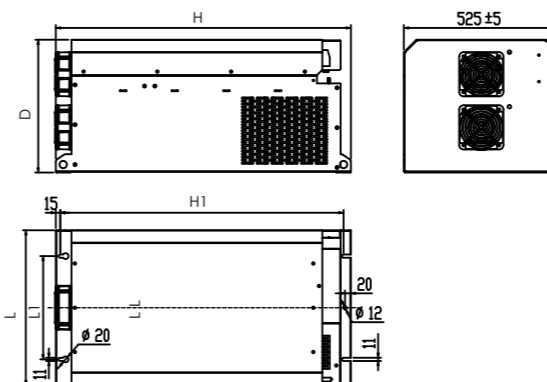

H5

机型 model	尺寸Size (±2mm)					
	L	D	H	L1	H1	A/B
H5	525	450	1000	350	960	11*20

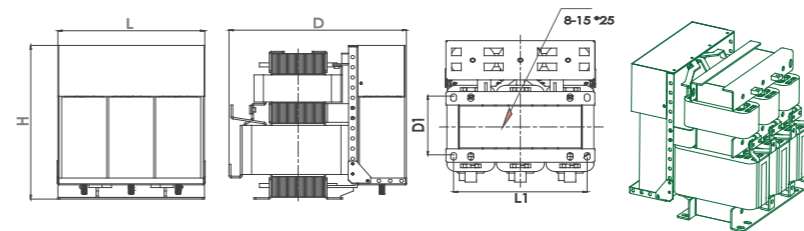

H6/H7/H8/H9

机型 model	尺寸Size (max)					
	L	D	H	L1	D1	A/B
H6	400	490	460	350/260	206	15*25
H7	430	570	735	380	202	12*40
H8	520	570	800	461	164	12*40
H9	520	575	840	461	184	12*40
H10	520	600	840	461	224	12*40
H11	520	615	840	461	224	12*40

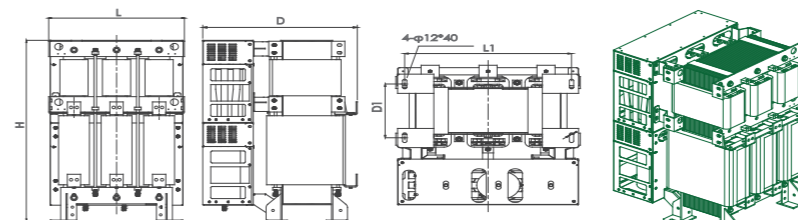

H10/H11

谐波滤波器 B系列 380-415V-50Hz-5%-IP20 Harmonic filter Series B 380-415V-50Hz-5%-IP20

谐波滤波器型号 Harmonic filter type	额定负荷功率 Rated load power [kW]	电机驱动输入 电流 [Arms] Motor drive input current	额定滤波器输入 电流 [Arms] Rated filter input current	净重 [kg] Net weight	毛重 [kg] Gross weight	典型损耗 [W] Typical loss	适配电缆 [m ²] Adapter cable	机型 model
HFR005X4SC001B06	0.4-1.5	1-3.7	0.5-2.2	10	17.5	29.5	06	H1
HFR005X4SC002B06	2.2	5	3.28	23	34.5	45	06	H1
HFR005X4SC005B06	3.7-5.5	10.5	8.2	30	37.5	75	06	H1
HFR005X4SC007B06	7.5	14.4	11.2	40	45	100	06	H1
HFR005X4SA011B10	11	22	16.5	50	60	125	10	H1
HFR005X4SA015B10	15	29	22.5	60	75	225	10	H2
HFR005X4SA022B16	18.5-22	40	32.5	60	90	300	16	H2
HFR005X4SA030B16	30	55	44.5	70	105	360	16	H2
HFR005X4SA037B35	37	66	54.8	80	120	420	35	H3
HFR005X4SA045B35	45	80	66.8	100	150	470	35	H3
HFR005X4SA055B50	55	96	81.8	110	165	560	50	H3
HFR005X4SA075B99	75	150	111	110	165	750	99	H4
HFR005X4SA090B99	90	180	134	120	180	850	99	H4
HFR005X4SA110B99	110	217	164	130	195	950	99	H4

谐波滤波器 B系列 380-415V-50Hz-5%-IP20 Harmonic filter Series B 380-415V-50Hz-5%-IP20

谐波滤波器型号 Harmonic filter type	额定负荷功率 Rated load power [kW]	电机驱动输入 电流 [Arms] Motor drive input current	额定滤波器输入 电流 [Arms] Rated filter input current	净重 [kg] Net weight	毛重 [kg] Gross weight	典型损耗 [W] Typical loss	适配电缆 [m ²] Adapter cable	机型 model
HFR010X4SC001B06	0.4-1.5	1-3.7	0.5-2.2	10	17.5	29.5	06	H1
HFR010X4SC002B06	2.2	5	3.28	23	34.5	45	06	H1
HFR010X4SC005B06	3.7-5.5	10.5	8.2	30	37.5	75	06	H1
HFR010X4SC007B06	7.5	14.4	11.2	40	45	100	06	H1
HFR010X4SA011B10	11	22	16.5	50	60	125	10	H1
HFR010X4SA015B10	15	29	22.5	60	75	225	10	H2
HFR010X4SA022B16	18.5-22	40	32.5	60	90	300	16	H2
HFR010X4SA030B16	30	55	44.5	70	105	360	16	H2
HFR010X4SA037B35	37	66	54.8	80	120	420	35	H3
HFR010X4SA045B35	45	80	66.8	100	150	470	35	H3
HFR010X4SA055B50	55	96	81.8	110	165	560	50	H3
HFR010X4SA075B99	75	150	111	110	165	750	99	H4
HFR010X4SA090B99	90	180	134	120	180	850	99	H4
HFR010X4SA110B99	110	217	164	130	195	950	99	H4

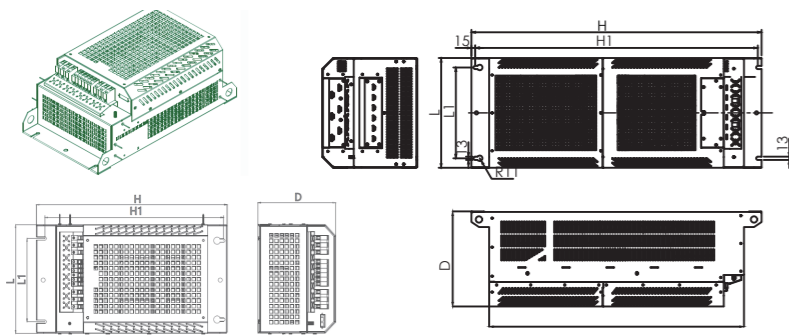

H1/H2/H3

H4

机型 model	尺寸Size (max)					
	L	D	H	L1	H1	A/B
H1	300	230	555	216	525	11*18
H2	410	275	650	350	640	11*15
H3	410	380	700	350	660	11*15
H4	450	390	1160	360	1120	11*15

谐波滤波器 N系列 380-415V-50Hz-5%-IP20 Harmonic filter Series B 380-415V-50Hz-5%-IP20

谐波滤波器型号 Harmonic filter type	额定负荷功率 Rated load power [kW]	电机驱动输入 电流 [Arms] Motor drive input current	额定滤波器输入 电流 [Arms] Rated filter input current	净重 [kg] Net weight	毛重 [kg] Gross weight	典型损耗 [W] Typical loss	适配电缆 [m ²] Adapter cable	机型 model
HFR005X4SC001N06	0.4-1.5	1-3.7	0.5-2.2	10	17.5	29.5	06	H1
HFR005X4SC002N06	2.2	5	3.28	23	34.5	45	06	H1
HFR005X4SC005N06	3.7-5.5	11	8.2	22	33	45	06	H1
HFR005X4SC007N06	7.5	15	11.2	28	42	75	06	H1
HFR005X4SC011N10	11	22	16.5	38	57	100	10	H2
HFR005X4SA015N10	15	30	22.5	48	72	125	10	H3
HFR005X4SA022N16	18.5-22	45	32.5	55	82.5	225	16	H4
HFR005X4SA030N16	30	60	44.5	66	99	300	16	H4
HFR005X4SA037N35	37	80	54.8	72	108	360	35	H4
HFR005X4SA045N35	45	90	66.8	93	139.5	420	35	H5
HFR005X4SA055N50	55	110	81.8	112	168	470	50	H6
HFR005X4SA075N99	75壁挂	150	111	125	187.5	560	99	H7
HFR005X4SA090N99	90壁挂	180	134	145	217.5	750	99	H8
HFR005X4SA110N99	110壁挂	217	164	165	247.5	850	99	H9
HFR005X4SA132N99	132壁挂	259	197	175	262.5	950	99	H10
HFR005X4SA160N99	160	290	240	385	577.5	1300	99	H11
HFR005X4SA200N99	200	370	296	430	645	1500	99	H11
HFR005X4SA250N99	220/250	520	356	485	727.5	1750	99	H11
HFR005X4SA315N99	315	580	444	520	780	2150	99	H11
HFR005X4SA355N99	355	650	500	570	855	2350	99	H11

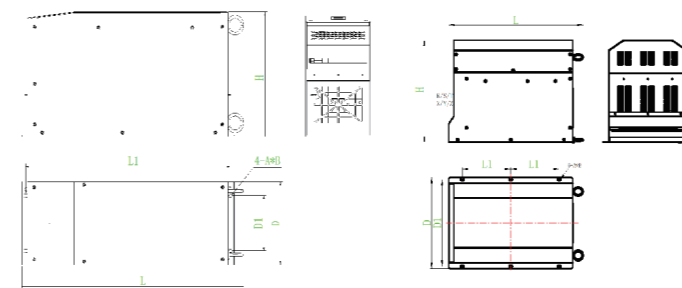

H1/H2/H3/H4/H5/H6

H7/H8/H9/H10

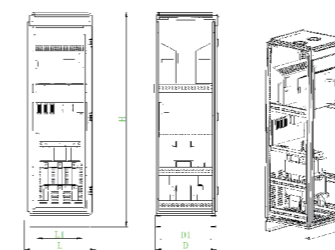

H11

机型 model	尺寸Size (max)					
	L	D	H	L1+2	D1+2	A/B
H1	415	235	215	355	165	φ16φ9
H2	460	265	270	390	200	φ16φ9
H3	585	340	355	490	270	φ16φ9
H4	715	245	350	650	150	φ16φ9
H5	750	330	370	675	150	φ16φ9
H6	750	330	370	675	150	6-10*20
H7	750	475	530	275*2	445	6-10*20
H8	750	475	580	275*2	445	6-10*20
H9	750	475	600	275*2	445	6-10*20
H10	750	475	600	275*2	445	4-φ13
H11	600	600	2200	535	525	4-φ13