

提供专业的电力电子无源器件产品及解决方案
Provide professional electronic electronic passive devices products and solutions



GATALOGUE 2024

Vishayd Semiconductor Co.,Ltd

No 945-947, 9th Floor, No 2,
Lane 1518, Jinshajiang Road
Putuo District, Shanghai, China

Tel/Fax: +86 21 336 346 49
E-mail: info@vahnder.com
Website: vahnder.com



Contents

电抗器系列

交流输入电抗器 (ACR) AC Input Reactor	01
交流输出电抗器 (OCR) AC Output Reactor	04
直流电抗器 (DCR) DC reactor	07
谐波滤波器 (HFR) Harmonic Filter	09
dv/dt滤波器 (VTR) dv/dt Filter	21
正弦波滤波器 (SFR) Sine Wave Filter	25
LCL滤波器 (LCR) LCL Filter	28
中频正弦波滤波器 High frequency SineWave Filter	29
能量回馈电抗器 (EFR) Energy Regenerated Reactor	31
空心电抗器 (HAR) Core reactor	32
变频器尖峰电压吸收器 Inverter peak votlage absorber	33
调谐电抗器 (ATR) Tuning Reactor	35
中压电抗器 Medium voltage reactor	37
水冷电抗器 (WCR) Water-cooled reactor	39
高频电抗器 (HER) High frequency Reactor	41

滤波器系列 (RF)

变频器专用滤波器 Special Filter For Inverter	43
三相四线滤波器 3-phase + Neutral Line Filters	46
单相滤波器 1-phase Filter	48
线噪声滤波器 Line noise filter	50

变压器系列

单/三相隔离变压器 (BKSC) Single/Three-phase Isolation transformer	52
自耦变压器 (BYSC) Autotransformer	55
整流变压器 (ZKSC) Rectifier transformer	56
逆变输出变压器 (NKSC) Inverter transformer	56

电阻器系列

波纹电阻器 (RXHG) Wire Wound Resistor	67
铝壳电阻器 (RXLG) Aluminum shell resistor	69
波纹电阻箱/柜 (BRU / HRU) Resistor Assemblies/High Power Resistor Assemblies	71

电阻器系列

铝壳电阻箱 (LRA) Aluminum Enclosure Resistor Assemblies	72
加热管电阻箱 (JRA) Heating pipe Resistor Assemblies	73
不锈钢电阻柜 (SRA) SUS Resistor Assemblies	74
中性点接地电阻 (NRA) Neutral Grounding Resistor	75
Crowbar / Chopper 电阻器 Crowbar / Chopper Resistor	76
功率型厚膜电阻器 Crowbar / Chopper Resistor	77

制动单元

制动单元 DBU DC Braking unit	81
能量回馈单元 Regenerative Unit	82

负载系列

负载箱 (TRA) Load Testing	83
---------------------------	----

滤波器 APF SVG

有源电力滤波器 Active power filters	86
Static Var Generator SVG	89

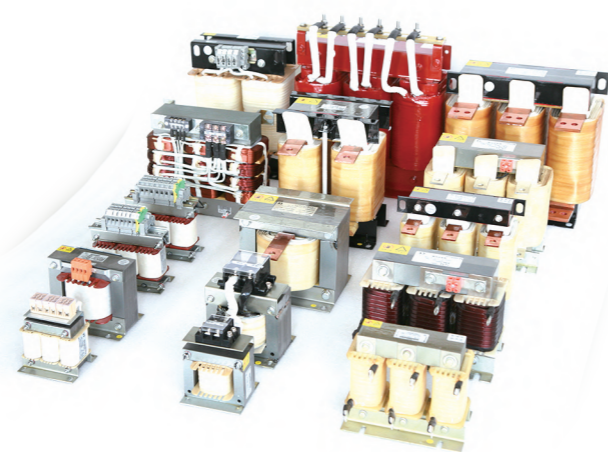

电机驱动系统解决方案 Motor drive system solutions

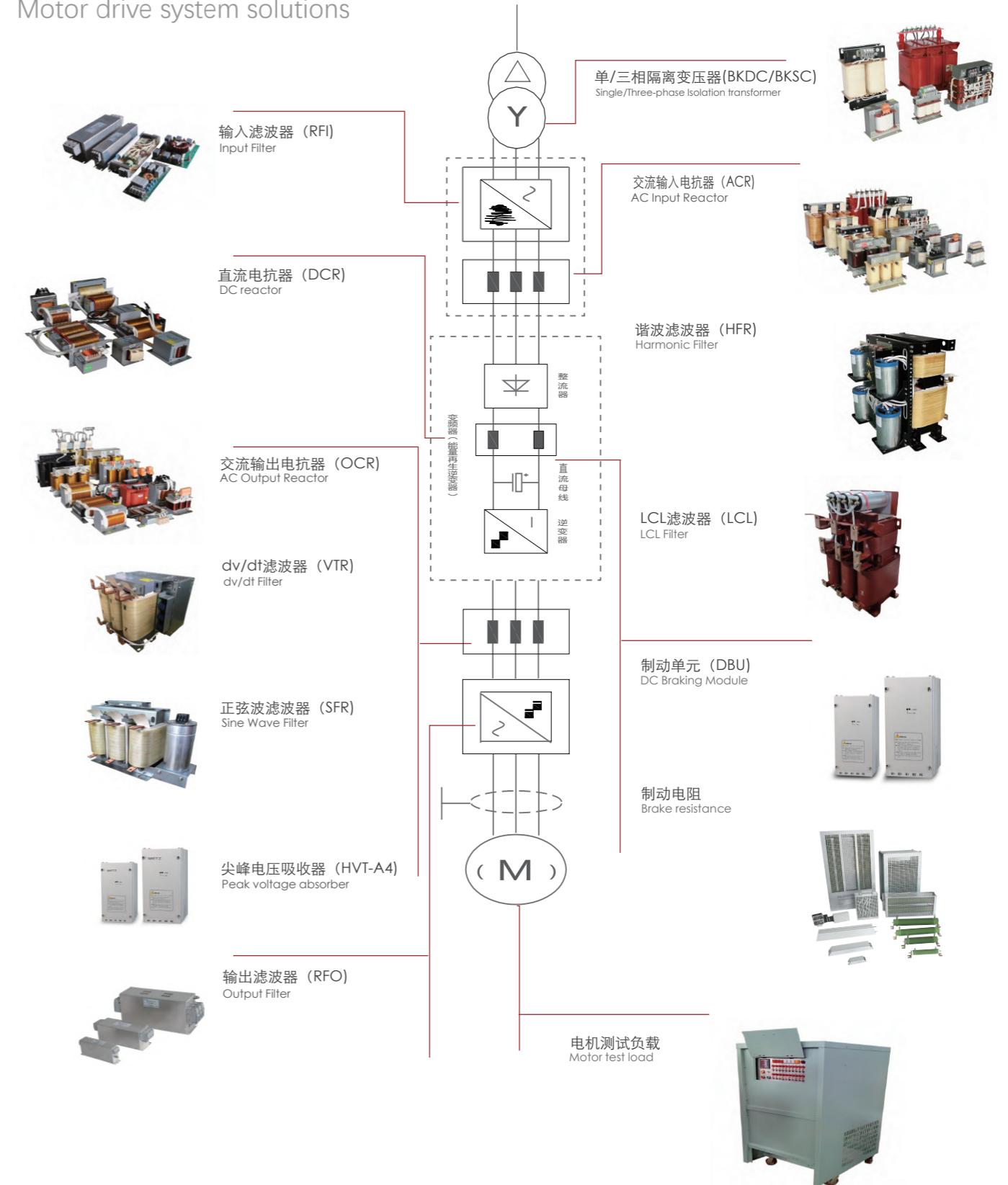

交流输入电抗器 (ACR) AC Input Reactor

■ 产品概述 (Product Introduction)

进线电抗器可被用于给线路电源提供改进的过载保护,并能减小变频器产生的电流谐波失真。提高输入电源的功率因素,减少高次谐波,抑制变频器在电源设备上的浪涌。

Input reactors orrer overload to line power supply and reduce harmonic distortion arising from frequency inverters,also improve the input supply,reduce ultraharmonic and suppress the surge caused by frequency inverters to the power supply units.

■ 产品应用 (Product Application)

特别在下列环境下推荐使用进线电抗器:

- 1.几个变频器并联紧密连接
- 2.线路电源有来自其他设备的明显 扰动 (干扰, 过电压)
- 3.线路电源各相之间存在电压不平衡, 超过额定电压的1.8%
- 4.在同一线路上安装有大量的变频器
- 5.减小 $\cos \phi$ 校正电容器上的过载, 如果装置中含有一个功率系数校正设备

Particularly apply to the following cases:

1. Multiple frequency inverters in close parallel connection
2. Other devices produce interference to line power supply.(disturbance,, over voltage
3. Nonbalance among phases of line power supply.(1.8% over than of the rated voltage
4. Massive frequency inverters installed on the same line
5. Reduce $\cos \phi$ and correct the overload of capacitor,in case the power factor correction devices are installed in system

■ 技术规格 (Technical Specifications)

工作电压 Work Voltage:	220VAC-3300VAC
工作频率 Work Frequency:	50/60Hz.
工作电流 Work Current:	3A-1600A
绝缘等级,Insulation Class:	class F,H
防护等级,Protection class:	IP00-IP22
压降 Voltage drop:	< 4% 大于此范围会引起转矩损失
最大电流 Max Current:	1.5× rated current, Constant 60S
噪音 Noise:	≤65dB
温升 Temperature Rise:	≤85K
抗电强度 Dielectric strength:	铁芯-绕组 3000VAC/50Hz/5mA/10s无飞弧击穿(工厂测试)
绝缘电阻 Insulation Resistor:	1000VDC绝缘阻值 ≥ 100MΩ

使用环境: -10~+45 °C.额定值不会降低。最高可达+55°C, 在45°C以上, 每升高1°C, 额定电流降低2%, 海拔高度不超过2000米。

运行环境温度 -25°C~+45°C, 相对湿度不超过90%。

周围无有害气体, 无易燃易爆物品。

周围环境应有良好的通风条件, 如装在柜内, 应加装通风设备。

Operation Environment:-10~+45 °C, rated value won't lower, when higer than 55 C, and every 1 C, the current will step down 2%, Under seal level 2000m

Running ambient temperature -25 °C ~ +45 °C, comparative moisture not over 90%.

No hazardous gas, no inflammables and explosives

With well-ventilated condition, ventilation devices shall be mounted if installioh in panels

典型电路图

Typical Circuit Diagram

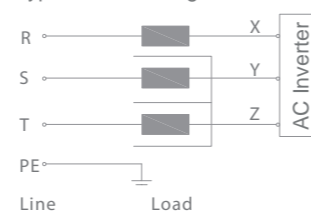

■ 执行标准 (Applicable Standards)

IEC289: 1987 Reactor

GB10229-88 Reactor (eqvIEC289: 1987)

JB9644-1999 Reactors used for semiconductor electrical driving

■ 产品尺寸图 (Product Size)

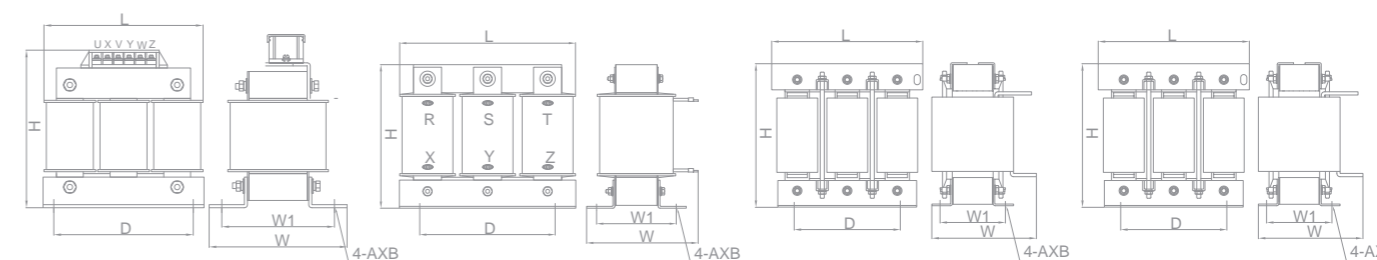

Picture A

Picture B

Picture C

Picture D

380V输入电抗器 380V AC Input Reactor

电抗器型号 Reactor Type	图号 Picture NO.	适配功率 Power (kw)	额定电流 Rated Current(A)	电感量 Inductance Value(mH)	压降 Voltage Drop	绝缘等级 Insulation rank	尺寸 Dimension(±5mm)					
							L	D	W	W1	H	AxB
ACR-0005-2M80-0.4SC	图 A Picture A	1.5	5	2.8	2%	F、H	115	90	95	70	135	6X11
ACR-0007-2M00-0.4SC		2.2	7	2	2%	F、H	115	90	95	70	135	6X11
ACR-0010-1M40-0.4SC		3.7	10	1.4	2%	F、H	115	90	95	70	135	6X11
ACR-0015-0M94-0.4SC		5.5	15	0.94	2%	F、H	115	90	95	70	135	6X11
ACR-0020-0M70-0.4SC	图 B Picture B	7.5	20	0.7	2%	F、H	115	90	95	70	135	6×15
ACR-0030-0M47-0.4SC		11	30	0.47	2%	F、H	155	95	130	63	135	6×15
ACR-0040-0M36-0.4SC		15	40	0.36	2%	F、H	155	95	135	76	135	6×15
ACR-0050-0M28-0.4SC		18.5	50	0.28	2%	F、H	155	95	135	76	135	6×15
ACR-0060-0M24-0.4SC	图 C Picture C	22	60	0.24	2%	F、H	195	120	135	72	165	8.5×20
ACR-0080-0M18-0.4SC		30	80	0.18	2%	F、H	195	120	155	92	165	8.5×20
ACR-0090-0M16-0.4SC		37	90	0.156	2%	F、H	195	120	155	92	165	8.5×20
ACR-0120-0M12-0.4SA		45	120	0.117	2%	F、H	230	150	170	83	220	11×18
ACR-0150-094U-0.4SA	图 D Picture D	55	150	0.094	2%	F、H	230	150	170	88	220	11×18
ACR-0200-070U-0.4SA		75	200	0.07	2%	F、H	250	182	175	98	230	11×18
ACR-0250-056U-0.4SA		110	250	0.056	2%	F、H	250	182	175	98	230	11×18
ACR-0290-048U-0.4SA		132	290	0.048	2%	F、H	290	214	200	102	250	11×18
ACR-0330-042U-0.4SA	图 D Picture D	160	330	0.042	2%	F、H	290	214	200	102	250	11×18
ACR-0390-036U-0.4SA		185	390	0.036	2%	F、H	290	214	205	107	250	11×18
ACR-0490-028U-0.4SA		220	490	0.028	2%	F、H	320	243	230	124	320	12×20
ACR-0600-024U-0.4SA		280	600	0.024	2%	F、H	320	243	250	140	320	12×20
ACR-0660-022U-0.4SA	图 D Picture D	300	660	0.022	2%	F、H	320	243	250	140	320	12×20
ACR-0800-17U5-0.4SA		380	800	0.0175	2%	F、H	365	260	280	135	390	15×25
ACR-1000-014U-0.4SA		450	1000	0.014	2%	F、H	365	260	280	139	410	15×25
ACR-1200-11U7-0.4SA		550	1200	0.0117	2%	F、H	395	260	340	160	390	15×25
ACR-1600-08U6-0.4SA		630	1600	0.0086	2%	F、H	395	260	340	160	435	15×25

备注: 其他规格尺寸, 可根据用户要求制造。Remark: Dimension can be customization

电抗器型号 Reactor Type	图号 Picture NO.	适配功率 Power (kw)	额定电流 Rated Current(A)	电感量 Inductance Value(mH)	压降 Voltage Drop	绝缘等级 Insulation rank	尺寸 Dimension(±5mm)					
							L	W	H	D	W1	A×B
ACR-0005-5M60-0.7SC	图 A Picture A	3.7	5	5.6	2%	F、H	155	80	180	95	61	6X15
ACR-0007-4M00-0.7SC		5.5	7	4	2%	F、H	155	80	180	95	61	6X15
ACR-0010-2M80-0.7SC		7.5	10	2.8	2%	F、H	155	80	180	95	61	6X15
ACR-0015-1M87-0.7SC		11	15	1.87	2%	F、H	155	91	180	95	76	6X15
ACR-0020-1M40-0.7SC	图 B Picture B	15/18.5	20	1.4	2%	F、H	155	91	180	95	76	6X15
ACR-0030-0M93-0.7SC		22	30	0.93	2%	F、H	195	140	165	120	92	8.5X20
ACR-0040-0M70-0.7SC		30	40	0.7	2%	F、H	195	145	165	120	92	8.5X20
ACR-0050-0M56-0.7SA		37/45	50	0.56	2%	F、H	195	150	165	120	92	8.5X20
ACR-0060-0M47-0.7SA	图 C Picture C	55	60	0.47	2%	F、H	200	180	165	120	110	8.5X20
ACR-0080-0M35-0.7SA		75	80	0.35	2%	F、H	250	200	230	182	94	11X18
ACR-0090-0M31-0.7SA		90	90	0.31	2%	F、H	250	200	230	182	94	11X18
ACR-0120-0M23-0.7SA		110	120	0.23	2%	F、H	250	190	230	182	113	11X18
ACR-0150-0M19-0.7SA	图 D Picture D	132	150	0.19	2%	F、H	290	210	250	214	112	11X18
ACR-0200-0M14-0.7SA		160/185	200	0.14	2%	F、H	290	220	250	214	122	11X18
ACR-0250-0M11-0.7SA		220	250	0.11	2%	F、H	290	220	250	214	122	11X18
ACR-0290-096U-0.7SA		240	290	0.096	2%	F、H	320	250	285	243	134	11X18
ACR-0330-085U-0.7SA	图 D Picture D	280/300	330	0.085	2%	F、H	320	250	285	243	150	11X18
ACR-0390-072U-0.7SA		380	390	0.072	2%	F、H	320	260	320	243	150	11X18
ACR-0490-057U-0.7SA		450	490	0.057	2%	F、H	380	300	340	260	160	15X25
ACR-0600-047U-0.7SA		550	600	0.047	2%	F、H	380	320	340	260	184	15X25
ACR-0660-042U-0.7SA		630	660	0.042	2%	F、H	380	320	340	260	186	15X25

备注：其他规格尺寸，可根据用户要求制造。Remark: Dimension can be customization

成品识别码 (Product Identification Code)

ACR	—	0060	—	0M24	—	0.4SC
输入电抗器 AC Input Reactor		额定电流 Rated Current 3A-1600A		电感量 Resistance Value M:mH U:uH		0.4:Working Voltage 0.2=220V,0.4=380V,0.7=690V,1.1=1140V S: D=Single Phase Reactor S=Three Phase Reactor C: C=Copper A:Aluminium



交流输出电抗器 (OCR) AC Output Reactor

产品概述 (Product Introduction)

安装在变频器输出端，用于限制变频器与电机连接电缆的容性充电电流，钝化变频器输出的PWM波的电压上升率。电机电缆长度超过一定值时，建议在变频器与电机之间插入一个电机电抗器。用于补偿在长导线时的电容再充电电流。此最大长度决定于变频器的额定值以及电机电缆的类型。

Installed at the output end of the frequency converter, it is used to limit the capacitive charging current of the cable connecting the frequency converter and the motor, and to passivate the voltage rise rate of the PWM wave output by the frequency converter. When the length of the motor cable exceeds a certain value, it is recommended to insert a motor reactor between the

产品应用 (Product Application)

- 1.将dv/dt限制到500V/us
- 2.将电机端子上的过电压限制到：1000V至400V~(rms值) 1150V至460V~(rms值)
- 3.打开滤波器与电机之间的接触器所引起的滤波器干扰
- 4.减小电机接地泄漏电流

- 1.Limit dv / dt to 500V/us
- 2.Limit the overvoltage of motor terminal to: 1000V to 400V ~ (rms) 1150V to 460V ~ (rms)
- 3.Filter interference caused by opening the contactor between the filter and the motor
- 4.Reduce the earth leakage current of motor

技术规格 (Technical Specifications)

- 1.工作电压：220VAC-3300VAC
- 2.工作频率：50/60Hz.
- 3.额定电流：3A-1600A
- 4.载波频率：2-8KHz.
- 5.绝缘等级：class F,H
- 6.使用环境：-10~+45℃,额定值不会降低。最高可达+55℃,在45℃以上,每升高1℃,额定电流降低2%
- 7.防护等级：IP00-IP22
- 8.压降：<4% 大于此范围会引起转矩损失
- 9.最大电流：1.5×额定电流,持续60S
- 10.噪音：≤65dB
- 11.温升：≤85K
- 12.抗电强度：铁芯-绕组 3000VAC/50Hz/5mA/10s无飞弧击穿(工厂测试)
- 13.绝缘电阻：1000VDC绝缘阻值≥100MΩ
- 14.海拔高度不超过2000米。
- 15.运行环境温度-25℃~+45℃,相对湿度不超过90%。
- 16.周围无有害气体,无易燃易爆物品。
- 17.周围环境应有良好的通风条件,如装在柜内,应加装通风设备。

- 1.Work voltage: 220VAC-3300VAC
- 2.Work frequency: 50/60Hz.
- 3.Work current: 3A-1600A
- 4.Carrier frequency :2-8KHz
- 5.Insulation class: class F, H
- 6.Operation Environment:-10℃+45℃,rated value won't lower,when higer than 45℃,and every 1℃,the current will step down 2%
- 7.Protection class: IP00-IP22
- 8.Voltage drop: <4% higher than the range will cause the loss of torque
- 9.Max Current: 1.5 × Rated current,continuous 60S
- 10:Noise: ≤ 65dB
- 11.Temperature Rise: ≤ 85K
- 12 Dielectric strength: Core Coil 3000VAC/50Hz/5mA/10s no electric arcing puncture (factory test)
- 13.Insulation Resistor: 1000VDC insulation resistance value ≥ 100MΩ
- 14.Under seal level 2000m
- 15.Running ambient temperature -25℃~+45℃, comparative moisture not over 90%.
- 16.No hazardous gas,no inflammables and explosives
- 17.With well-ventilated condition,ventilation devices shall be mounted if installation in panels

典型电路图
Typical Circuit Diagram

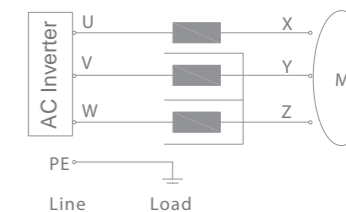

■ 执行标准 (Applicable Standards)

IEC289: 1987 Reactor
 GB10229-88 Reactor (eqvIEC289: 1987)
 JB9644-1999 Reactors used for semiconductor electrical driving

■ 产品尺寸图 (Product Size)

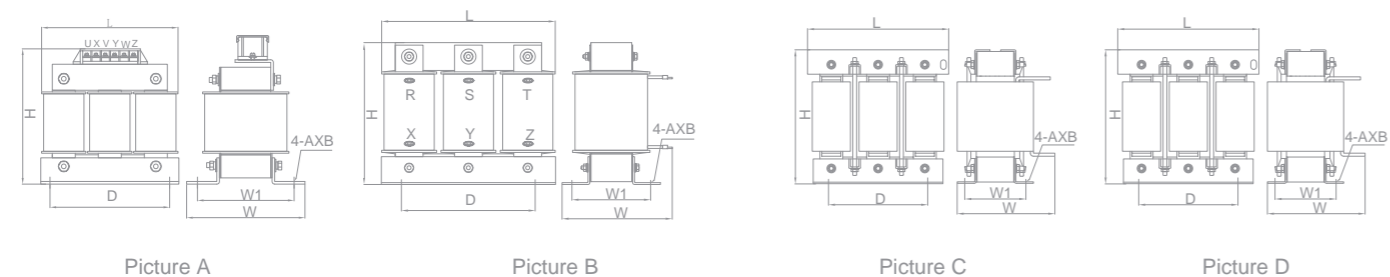

380V输出电抗器 380V AC Output Reactor

电抗器型号 Reactor Type	图号 Picture NO.	适配功率 Power (kw)	额定电流 Rated Current(A)	电感量 Inductance Value(mH)	压降 Voltage Drop	绝缘等级 Insulation rank	尺寸 Dimension(±5mm)					
							L	D	W	W1	H	AxB
OCR-0005-1M40-0.4SC	图 A Picture A	1.5	5	1.4	1%	F、H	110	90	95	70	130	6X11
OCR-0007-1M00-0.4SC		2.2	7	1	1%	F、H	110	90	95	70	130	6X11
OCR-0010-0M70-0.4SC		3.7	10	0.7	1%	F、H	110	90	95	70	130	6X11
OCR-0015-0M47-0.4SC		5.5	15	0.47	1%	F、H	110	90	95	70	130	6X11
OCR-0020-0M35-0.4SC	图 B Picture B	7.5	20	0.35	1%	F、H	110	90	95	70	130	6X11
OCR-0030-0M23-0.4SC		11	30	0.23	1%	F、H	155	95	130	61	150	6x15
OCR-0040-0M18-0.4SC		15	40	0.18	1%	F、H	155	95	130	63	135	6x15
OCR-0050-0M14-0.4SC		18.5	50	0.14	1%	F、H	155	95	140	76	135	6x15
OCR-0060-0M12-0.4SC	图 C Picture C	22	60	0.12	1%	F、H	195	120	135	72	165	8.5x20
OCR-0080-087U-0.4SC		30	80	0.087	1%	F、H	195	120	135	72	165	8.5x20
OCR-0090-078U-0.4SC		37	90	0.078	1%	F、H	195	120	135	72	165	8.5x20
OCR-0120-058U-0.4SA		45	120	0.058	1%	F、H	230	150	165	83	220	11x18
OCR-0150-047U-0.4SA	图 D Picture D	55	150	0.047	1%	F、H	230	150	170	88	220	11x18
OCR-0200-035U-0.4SA		75	200	0.035	1%	F、H	230	150	180	98	220	11x18
OCR-0250-028U-0.4SA		110	250	0.028	1%	F、H	250	182	175	98	230	11x18
OCR-0290-024U-0.4SA		132	290	0.024	1%	F、H	290	214	200	107	250	11x18
OCR-0330-021U-0.4SA	图 D Picture D	160	330	0.021	1%	F、H	290	214	200	107	250	11x18
OCR-0390-018U-0.4SA		185	390	0.018	1%	F、H	290	214	200	107	250	11x18
OCR-0490-014U-0.4SA		220	490	0.014	1%	F、H	320	243	230	125	320	11x18
OCR-0600-012U-0.4SA		280	600	0.012	1%	F、H	320	243	250	140	320	11x18
OCR-0660-011U-0.4SA	图 D Picture D	300	660	0.011	1%	F、H	320	243	250	140	320	11x18
OCR-0800-08U7-0.4SA		380	800	0.0087	1%	F、H	365	260	280	135	390	15x25
OCR-1000-07U0-0.4SA		450	1000	0.007	1%	F、H	365	260	280	135	390	15x25
OCR-1200-05U8-0.4SA		550	1200	0.0058	1%	F、H	395	260	325	150	390	15x25
OCR-1600-04U3-0.4SA		630	1600	0.0043	1%	F、H	395	260	325	150	435	15x25

备注：其他规格尺寸，可根据用户要求制造。Remark: Dimension can be customization

690V输出电抗器 690V AC Output Reactor

电抗器型号 Reactor Type	图号 Picture NO.	适配功率 Power (kw)	额定电流 Rated Current(A)	电感量 Inductance Value(mH)	压降 Voltage Drop	绝缘等级 Insulation rank	尺寸 Dimension(±5mm)					
							L	D	W	W1	H	AxB
OCR-0005-2M80-0.7SC	图 A Picture A	3.7	5	2.8	1%	F、H	155	80	180	95	61	6X15
OCR-0007-2M00-0.7SC		5.5	7	2	1%	F、H	155	80	180	95	61	6X15
OCR-0010-1M40-0.7SC		7.5	10	1.4	1%	F、H	155	80	180	95	61	6X15
OCR-0015-0M93-0.7SC		11	15	0.93	1%	F、H	155	80	180	95	63	6X15
OCR-0020-0M70-0.7SC	图 B Picture B	15/18.5	20	0.7	1%	F、H	155	80	180	95	63	6X15
OCR-0030-0M47-0.7SC		22	30	0.47	1%	F、H	195	130	165	120	72	8.5X20
OCR-0040-0M35-0.7SC		30	40	0.35	1%	F、H	195	130	165	120	72	8.5X20
OCR-0050-0M28-0.7SA		37/45	50	0.28	1%	F、H	195	150	165	120	92	8.5X20
OCR-0060-0M23-0.7SA	图 C Picture C	55	60	0.23	1%	F、H	195	150	165	120	92	8.5X20
OCR-0080-0M18-0.7SA		75	80	0.18	1%	F、H	195	190	165	120	110	8.5X20
OCR-0090-0M16-0.7SA		90	90	0.16	1%	F、H	230	200	230	150	94	11X18
OCR-0120-0M12-0.7SA		110	150	0.12	1%	F、H	250	175	230	182	103	11X18
OCR-0150-094U-0.7SA	图 D Picture D	132	200	0.094	1%	F、H	250	200	230	182	113	11X18
OCR-0200-070U-0.7SA		160/185	250	0.07	1%	F、H	290	200	250	214	112	11X18
OCR-0250-055U-0.7SA		220	290	0.055	1%	F、H	290	210	250	214	122	11X18
OCR-0290-048U-0.7SA		240	330	0.048	1%	F、H	320	250	285	243	134	11X18
OCR-0330-042U-0.7SA	图 D Picture D	280/300	390	0.042	1%	F、H	320	250	285	243	134	11X18
OCR-0390-036U-0.7SA		380	490	0.036	1%	F、H	320	250	285	243	134	11X18
OCR-0490-028U-0.7SA		450	600	0.028	1%	F、H	320	270	320	243	154	11X18
OCR-0600-023U-0.7SA		550	660	0.023	1%	F、H	365	285	350	260	164	15X25
OCR-0660-021U-0.7SA		630		0.021	1%	F、H	365	285	350	260	164	15X25

备注：其他规格尺寸，可根据用户要求制造。Remark: Dimension can be customization

■ 成品识别码 (Product Identification Code)

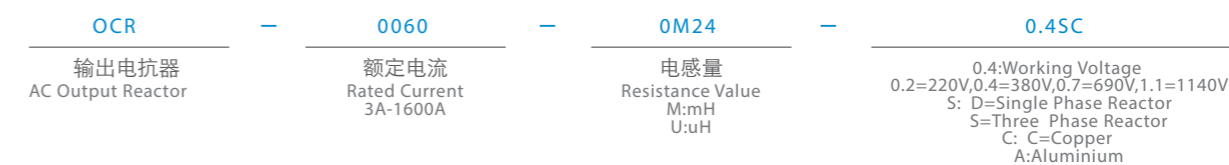

直流电抗器 (DCR) DC reactor

产品概述 (Product Introduction)

直流平波电抗器用于整流回路之中，抑制整流后的波纹脉动分量，并使整流后的电流连续不断，改善输出的支流波形，保证直流设备的正常运行。

DC smoothing reactor rectifier circuit being used to suppress ripple rectified pulsating component and make rectified current continuously Improve the output waveform tributaries, to ensure the normal operation of the DC devices.

产品应用 (Product Application)

1. 改善电容滤波造成的输入电流波形畸变。
2. 减少和防止因冲击电流造成整流桥损坏和电容过热。
3. 提高功率因素，降低直流母线交流脉冲。
4. 限制电网电压的瞬变。
5. 与并联连接的电容一起共同抑制或滤掉直流中的纹波，以排除对负载的不利影响。

1. Suppress the waveform distortion of input current caused by capacitive filtering
2. Reduce and avoid overheat of capacity and rectifier bridge damage both of which arise from surge current
3. Improve power factor and reduce the DC busbar AC pulse.
4. Limit the instant change of the grid voltage
5. Suppress or filter out ripple in DC together with capacitors connected in parallel to eliminate adverse effects on the load.

技术规格 (Technical Specifications)

1. 工作电压：220VAC-1140VAC
2. 工作频率：50/60Hz.
3. 工作电流：3A-1600A
4. 绝缘等级：class F,H
5. 使用环境：-10~+45℃,额定值不会降低。最高可达+55℃,在45℃以上，每升高1℃，额定电流降低2%
6. 防护等级：IP00-IP22
7. 最大电流：1.5×额定电流，持续60S
8. 噪音：≤65dB
9. 温升：≤85K
10. 抗电强度：铁芯-绕组 3000VAC/50Hz/5mA/10s无飞弧击穿(工厂测试)
11. 绝缘电阻：1000VDC绝缘阻值≥100MΩ
12. 海拔高度不超过2000米。
13. 运行环境温度-25℃~+45℃，相对湿度不超过90%。
14. 周围无有害气体，无易燃易爆物品。
15. 周围环境应有良好的通风条件，如装在柜内，应加装通风设备。

1. Work voltage: 220VAC-1140VAC
2. Work frequency: 50/60Hz.
3. Work current: 3A-1600A
4. Insulation class: class F, H
5. Operation Environment: -10~+45℃, rated value won't lower, when higher than 45℃, and every 1℃, the current will step down 2%
6. Protection class: IP00-IP22
7. Max Current: 1.5 × Rated current, continuous 60S
8. Noise: ≤ 65dB
9. Temperature Rise: ≤ 85K
10. Dielectric strength: Core Coil 3000VAC/50Hz/5mA/10s no electric arcing puncture (factory test)
11. Insulation Resistor: 1000VDC insulation resistance value ≥ 100MΩ
12. Under seal level 2000m
15. Running ambient temperature -25℃ ~ +45℃, comparative moisture not over 90%.
16. No hazardous gas, no inflammables and explosives
17. With well-ventilated condition, ventilation devices shall be mounted if installation in panels

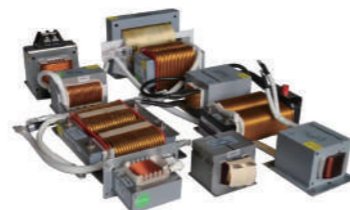

典型电路图
Typical Circuit Diagram

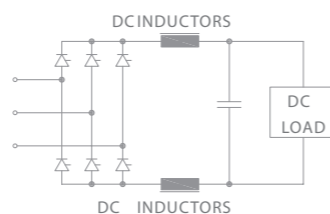

执行标准 (Applicable Standards)

IEC289: 1987 Reactor
GB10229-88 Reactor (eqvIEC289: 1987)
JB9644-1999 Reactors used for semiconductor electrical driving

产品尺寸图 (Product Size)

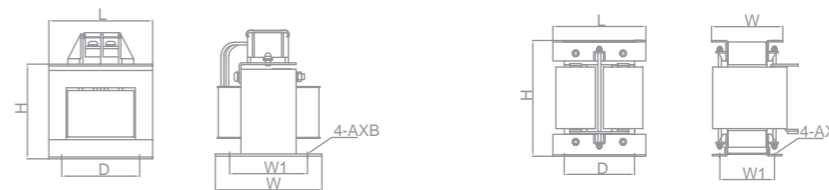

Picture A

Picture B

电抗器型号 Reactor Type	图号 Picture NO.	适配功率 Power (kw)	额定电流 Rated Current(A)	电感量 Inductance Value(mH)	绝缘等级 Insulation rank	尺寸 Dimension(±5mm)					
						L	D	W	W1	H	A×B
DCR-0010-6M30-0.4DC	图 A Picture A	4	10	6.3	F、H	110	87	120	70	135	6X12
DCR-0015-3M60-0.4DC		5.5	15	3.6	F、H	110	87	120	70	135	6X12
DCR-0020-3M60-0.4DC		7.5	20	3.6	F、H	110	87	120	70	135	6X12
DCR-0030-2M00-0.4DC		11	30	2	F、H	110	87	120	70	135	6X12
DCR-0040-2M00-0.4DC		15	40	2	F、H	110	87	120	70	135	6X12
DCR-0040-1M30-0.4DC		18.5	40	1.3	F、H	110	87	120	70	135	6X12
DCR-0050-1M08-0.4DC		22	50	1.08	F、H	120	95	135	85	145	8.5×14
DCR-0065-0M80-0.4DC		30	65	0.8	F、H	138	111	150	85	170	8.5×14
DCR-0080-0M70-0.4DC		37	80	0.7	F、H	138	111	150	85	170	8.5×14
DCR-0100-0M54-0.4DA		45	100	0.54	F、H	155	125	180	105	195	10×20
DCR-0120-0M45-0.4DA	55	120	0.45	F、H	155	125	160	90	195	10×20	
DCR-0160-0M36-0.4DA	75	160	0.36	F、H	155	125	180	105	200	10×20	
DCR-0200-0M33-0.4DA	90	200	0.33	F、H	155	100	180	98	215	10×20	
DCR-0250-0M26-0.4DA	110	250	0.26	F、H	210	176	200	115	255	11×18	
DCR-0300-0M26-0.4DA	132	300	0.26	F、H	210	176	150	115	255	11×18	
DCR-0350-0M17-0.4DA	160	350	0.17	F、H	210	176	150	115	255	11×18	
DCR-0450-090U-0.4DA	185	450	0.09	F、H	220	191	220	117	280	11×18	
DCR-0500-060U-0.4DA	220	500	0.06	F、H	220	191	220	117	280	11×18	
DCR-0650-050U-0.4DA	300	650	0.05	F、H	220	191	220	127	280	11×18	
DCR-0800-050U-0.4DA	380/400	800	0.05	F、H	250	200	245	144	320	11×18	
DCR-1000-050U-0.4DA	450	1000	0.05	F、H	250	200	280	146	360	11×18	
DCR-1200-050U-0.4DA	500	1200	0.04	F、H	250	200	280	164	390	11×18	

成品识别码 (Product Identification Code)

DCR	-	0060	-	0M24	-	0.4SC
直流电抗器 DC Reactor		额定电流 Rated Current 3A-1600A		电感量 Resistance Value M:mH U:uH		0.4:Working Voltage 0.2=220V,0.4=380V,0.7=690V,1.1=1140V S: D=Single Phase Reactor S=Three Phase Reactor C: C=Copper A:Aluminium

谐波滤波器 (HFR) Harmonic Filter

产品概述 (Product Introduction)

谐波滤波器 (HFR) 包括主电感器L1和L2和电感器L3以及电容器C组合的二级吸收电路,单元可配装互感器TA以及支路接触器KM,吸收电路需要特别调整,可改善以第5次和第5次以上的谐波电流。基波频率50HZ和基波频率60HZ的电路是不同的基波频率。滤波器性能随负载功能的变化而变化。额定负载下, HFR滤波器的性能THDi ≤ 5%或 ≤ 10%

The harmonic filter (HFR) includes a secondary absorption circuit consisting of main inductor L1 and L2, inductor L3, and capacitor C combination. The unit can be equipped with transformer TA and branch contactor KM, and the absorption circuit needs special adjustment to improve the harmonic current of the 5th and above. The circuits with a fundamental frequency of 50Hz and 60Hz have different fundamental frequencies. The filter performance varies with the load function. Under rated load, the performance of HFR filter THDi ≤ 5% or ≤ 10%

产品应用 (Product Application)

适用于各种前端是六脉冲整流的电力设备将谐波电流减小到规定限值以下。

日常用电负载,非线性负载占很大一部分。Applicable to a variety of front-end is six-pulse rectifier power equipment harmonic current to reduce the specified limit below. DailyElectrical Load, nonlinear load accounts for a large part.

HFR谐波滤波器可以快速方便地将标准电机驱动升级为低谐波驱动。

The HFR harmonic filter can quickly and conveniently upgrade the standard motor drive to the low harmonic drive.

其典型应用有: Typical applications include:

- 配备前端六脉冲整流器的设备
Equipment equipped with a front-end six-pulse rectifier
- AC和DC电动机驱动器
AC and DC motor drivers
- 工厂自动化设备
Factory automation equipment
- UPS及三相电源
UPS and three-phase power supply
- 水/废水处理设施
Water/wastewater treatment facilities
- 石油及天然气勘探
Oil and gas exploration

- 重工业及机械
Heavy industry and machinery
- 自给式系统 (如船舶)
A self-contained system (as of a ship)
- 风机及泵应用
Fan and pump applications
- 电池充电器
Battery Charger
- 供热通风与空调工程装置
Heating, ventilation and air conditioning engineering equipment
- 关键工程
Key projects

技术规格 (Technical Specifications)

额定工作电压 Rated working voltage	3×370 to 500VAC
电压容差范围 Voltage tolerance range	3×342 to 550VAC
工作频率 Operating frequency	50Hz/60Hz
电机驱动输入电流* Motor drives input current	10 to 500A@50° C
电机驱动输入功率 The motor drives the input power	4 to 315KW
总谐波电流畸变THID**	在额定功率下At rated power: THDi ≤ 5%/ ≤ 10%
效率 Efficiency	>98.5%
绝缘等级 Insulation grade	class F,H
抗电强度 Electrical strength	P=>E 2500VAC(1分钟)
防护等级 Protection level	IP00-IP20
冷却 Cooling	风冷 Air-cooled
过载容量 Overload capacity	1.5 * In / 60S
环境温度范围 Ambient temperature range	全操作状态 Full operational status: -25° C to +50° C 降容操作状态 Volume Reduction Operation Status: +50° C to +70° C*** 运输和存放 Transport and storage: -25° C to +85° C

* 谐波滤波器可以通过降低谐波电流和提高功率因数来降低有效输入和峰值电流。

The harmonic filter can reduce the effective input and peak current by reducing the harmonic current and increasing the power factor.

** 系统要求 System requirements: THDi < 2%, 线电压不平衡度 Line voltage unbalance < 1%.

*** Iderated=Inominal*√(85° C-Tamb) /35° C



* 谐波滤波器可以通过降低谐波电流和提高功率因数来降低有效输入和峰值电流。

The harmonic filter can reduce the effective input and peak current by reducing the harmonic current and increasing the power factor.

** 系统要求 System requirements: THDi < 2%, 线电压不平衡度 Line voltage unbalance < 1%.

*** Iderated=Inominal*√(85° C-Tamb) /35° C

对应负载时的THDi	HFR010	HFR005
40%负载	~12%	~7%
70%负载	~11%	~6%
100%负载	<10%	<5
100%负载下的效率*	>98.5%	
真实功率因数*		
40%负载	~81%	~80%
70%负载	~96%	~95%
100%负载	>99%	>98%
冷却	自冷/风冷	

谐波的影响很严重

谐波会降低系统效率,浪费宝贵的能量。谐波电流会导致电力装置、配电变压器、断路器、熔断器、导线等出现过载和过热。它们会使系统提前老化,或者需要增加电力系统的容量。谐波会使VAR补偿设备中的电容器组过载,并导致电子控制器出现故障,敏感医疗设备受到干扰,或者通信网络崩溃。

经济后果

很不幸,降低谐波需要付出较高的成本。在很多情况下,在项目规划阶段的预算中都不会考虑此成本。不过,如果忽视这个问题,可能需要为此付出多得多成本。可能需要增加电力设施的容量。设备可能会提前失效。在出现干扰的情况下可能会导致生产停产。电力公司甚至可能会开出违反电力质量要求的罚单,导致整个工厂必须临时从电网断开。

简单的即插即用操作

HFR滤波器为箱体结构,共有3个输入和3个输出接头。它们可以方便地集成到已有设计方案中,不需要进行深入系统分析,也不需要非常专业的人员操作。HFR滤波器不会从系统其它元器件吸收谐波,也不会导致系统共振。它们可以与安装在同一系统内的直流母线扼流圈以及EMC/EMI滤波器实现平滑操作。

因为采用了出色的电感器设计方法和先进的热控制方法,所以产品是市场上结构最紧凑的滤波器。传统的谐波抑制方法需要采用大型的单体机柜,而HFR体积小,重量轻,可以将滤波器方便地直接集成在电动机传动旁边的电气柜中。

增加设备寿命,保证可靠的生产运行时间

因为HFR滤波器采用了独特的设计,所以可以增加电源的阻抗,从而实现传统交流输入电抗器所有优点。比如,在电动机传动应用中,它们可以消除干扰跳闸,保护整流器和直流母线电容不受市电瞬变电流的影响。通过增加设备使用寿命并保证关键应用的可靠操作功能,可以降低成本并为利润提供保障。

在谐波源头(也就是在各非线性负载处)将其消除是最好的控制方式。只有这样,才能避免谐波电流和电压在整个系统中传播。HFR滤波器采用了独特的设计来解决这个问题,它们针对整流器所需的谐波电流采用了一个低阻抗,从而显著降低了流经配电系统的谐波。这样,非线性负载从电网吸收的电流基本都是正弦电流。

总谐波电流失真率和负荷率曲线

Total harmonic current distortion rate and load rate curve

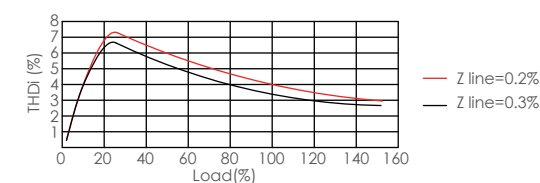

当负载负荷大于70%时,能将电流谐波THDI降到大约5%以下
全功率范围内能将电流谐波失真率THDI抑制在8%以内

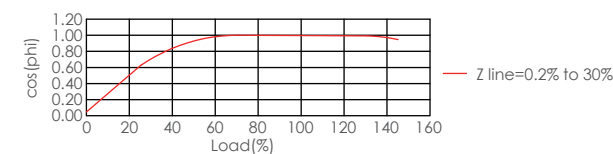

大功率变频器有直流电抗器时,额定功率下,能将电流谐波THDI降到5%以下
大功率变频器有直流电抗器时,全功率范围内,能将电流谐波THDI降到15%以下

变频器直流母线电压

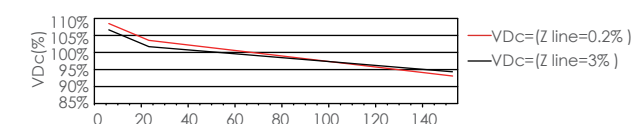

负载轻载时,变频器直流母线电压不超过110%
额定功率时,变频器直流母线电压不低于93%

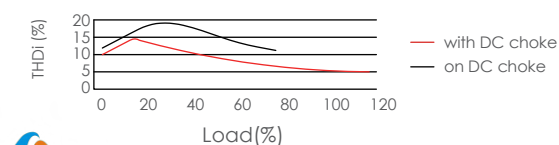

负载轻载时,大功率变频器直流母线电压不超过105%
额定功率时,大功率变频器直流母线电压不低于96%

实现高性能

在很多情况下，制造商只提高全负载条件下的滤波器性能，因为小负载条件下在降低谐波和处理电容电流方面存在困难。HFR滤波器不仅能保证在整个负载范围内的总谐波电流畸变率，而且还能限制所有条件下的电容电流值。

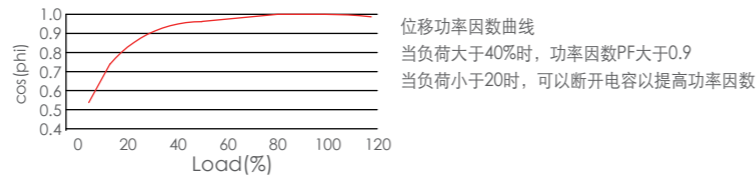

标准滤波器应用于不同行业的各种电网，用户可以选择多种功率，电流，电压和频率规格，因而能够选择最适合的滤波器。当然，用户可能还会有其他电气或机械要求，或者除了产品之外还需要其他服务。

拥有独特优势，能够帮助用户分析问题，提出工程建议，提供测试和测量支持，定制化产品。我们的目标是保证满足您的实际谐波抑制需求。

典型电路图

Typical circuit diagram

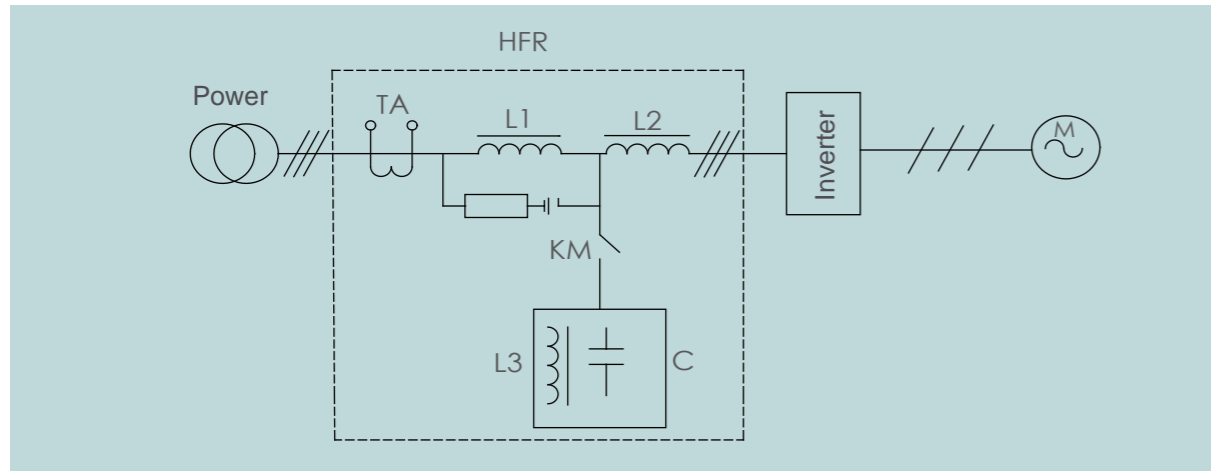

执行标准 (Applicable Standards)

EN61558-2-20
CE(LVD 2006/95/EC)

电气数据 (Electrical data)

无源系列类别目录 Passive series category catalog

电压系统 (V) ±10%	频率 (Hz)	总谐波电流失真 THID	IP 等级	功率范围 (kW)	效率	冷却方式	过载能力	产品无故障时间 MTBF	电流总需求量畸变系数 TDD	环境温度范围	短路电流额定值 SCCR	接地系统	超电压类别
380-415	50±1Hz	≤5% @额定功率	IP20	2.2	>98%	AN	1.6 倍额定电流 可维持 1分钟 每小时一次	>200,000 小时	根据 IEEE-519 标准	-25°C到+45°C 可正常运行 +45°C到+70°C 需要降低额定值 -25°C到+85°C 运输和储藏	100 kA	TN, TT, IT	OV III (IEC 60664-1 / UL 61800-5-1)
	50±1Hz	≤5% @额定功率	IP00										
	50±1Hz	≤10% @额定功率	IP20										
	50±1Hz	≤10% @额定功率	IP20										
440-500	50±1Hz	≤5% @额定功率	IP20	315	>98%	AN	1.6 倍额定电流 可维持 1分钟 每小时一次	>200,000 小时	根据 IEEE-519 标准	-25°C到+45°C 可正常运行 +45°C到+70°C 需要降低额定值 -25°C到+85°C 运输和储藏	100 kA	TN, TT, IT	OV III (IEC 60664-1 / UL 61800-5-1)
	50±1Hz	≤5% @额定功率	IP00										
	50±1Hz	≤10% @额定功率	IP20										
	50±1Hz	≤10% @额定功率	IP20										
380-415	60±1Hz	≤5% @额定功率	IP20	1	>98%	AN	1.6 倍额定电流 可维持 1分钟 每小时一次	>200,000 小时	根据 IEEE-519 标准	-25°C到+45°C 可正常运行 +45°C到+70°C 需要降低额定值 -25°C到+85°C 运输和储藏	100 kA	TN, TT, IT	OV III (IEC 60664-1 / UL 61800-5-1)
	60±1Hz	≤5% @额定功率	IP00										
	60±1Hz	≤10% @额定功率	IP20										
	60±1Hz	≤10% @额定功率	IP20										
440-500	60±1Hz	≤5% @额定功率	IP20	240	>98%	AN	1.6 倍额定电流 可维持 1分钟 每小时一次	>200,000 小时	根据 IEEE-519 标准	-25°C到+45°C 可正常运行 +45°C到+70°C 需要降低额定值 -25°C到+85°C 运输和储藏	100 kA	TN, TT, IT	OV III (IEC 60664-1 / UL 61800-5-1)
	60±1Hz	≤5% @额定功率	IP00										
	60±1Hz	≤10% @额定功率	IP20										
	60±1Hz	≤10% @额定功率	IP20										

* 系统要求: THVD <2%, 线电压不平衡 <1%

说明: 本手册提供的性能规格参考的是 6 脉冲二极管整流器。

可控硅整流器的前端可能产生不同结果，取决于晶体闸流管的发射角。

THID~5% (在额定功率下，针对 <6 kW 的滤波器)

** 请参阅数据表，了解冷却所要求的进气空气流量

*** Iderated = Inominal * (Tmax-Tamb)/(Tmax-Tnominal) = Inom * (70°C-Tamb)/25°C

**** 需要在外部增加 UL 级保险丝。请参阅用户手册

*System requirements: THVD<2%, line voltage imbalance<1%

Explanation: The performance specifications provided in this manual refer to a 6-pulse diode rectifier.

The front-end of a thyristor rectifier may produce different results depending on the emission angle of the thyristor.

THID~5% (at rated power, for filters<6 kW)

**Please refer to the data sheet for the required intake air flow rate for cooling

*** Iderated = Inominal * (Tmax-Tamb)/(Tmax-Tnominal) = Inom * (70°C-Tamb)/25°C

****We need to add UL grade fuses externally. Please refer to the user manual

成品识别码 (Product Identification Code)

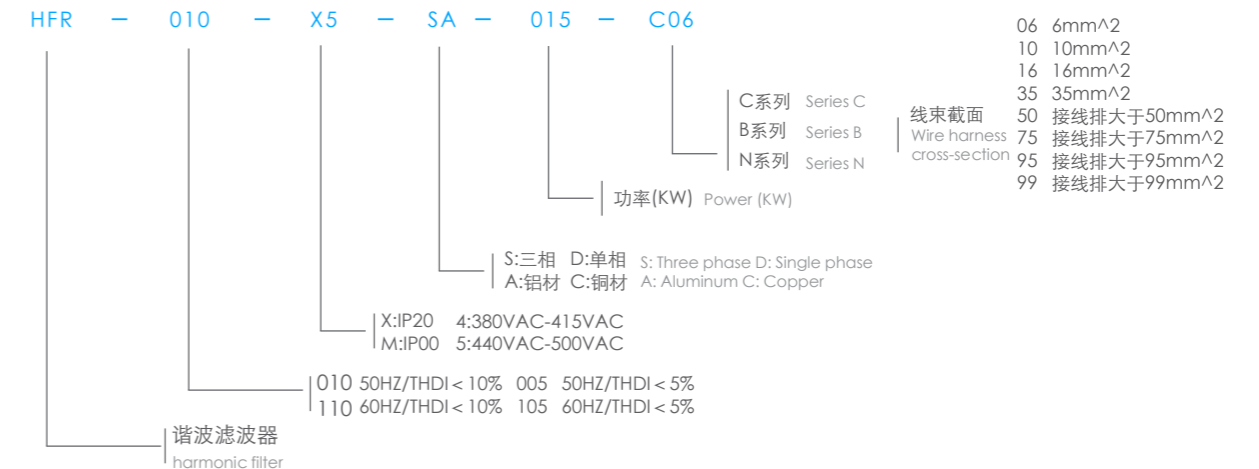

谐波滤波器C系列 380-415V-50Hz-5%-IP20 Harmonic filter C series 380-415V-50Hz-5%-IP20

谐波滤波器型号 Harmonic filter type	额定负荷功率 [kW] Rated load power	电机驱动输入电流 [Arms] Motor drive input current	额定滤波器输入电流 [Arms] Rated filter input current	净重 [kg] Net weight	毛重 [kg] Gross weight	典型损耗 [W] Typical loss	适配电缆 [m²] Adapter cable	机型 model
HFR005X4SC001C06	0.4-1.5	1-3.7	0.5-2.2	10	17.5	29.5	06	H1
HFR005X4SC002C06	2.2	5.5	3.28	14.5	21.75	45	06	H1
HFR005X4SC005C06	3.7-5.5	10-13	8.2	20	30	75	06	H1
HFR005X4SC007C06	7.5	16	11.2	26	39	100	06	H1
HFR005X4SA011C10	11	24	16.5	35	52.5	125	10	H1
HFR005X4SA015C10	15	30	22.5	45	67.5	225	10	H2
HFR005X4SA022C16	18.5-22	44	32.5	52	78	300	16	H2
HFR005X4SA030C16	30	60	44.5	63	94.5	360	16	H3
HFR005X4SA037C35	37	75	54.8	70	105	420	35	H3
HFR005X4SA045C35	45	90	66.8	88	132	470	35	H3
HFR005X4SA055C50	55	110	81.8	103	154.5	560	50	H3
HFR005X4SA075C99	75	150	111	118	177	750	99	H4
HFR005X4SA090C99	90	180	134	135	202.5	850	99	H4
HFR005X4SA110C99	110	210	164	158	237	950	99	H4
HFR005X4SA132C99	132	260	197	245.8	318.7	1050	99	H5
HFR005X4SA160C99	160	320	240	328.5	492.75	1300	99	H5

谐波滤波器C系列 380-415V-50Hz-5%-IP00 Harmonic filter C series 380-415V-50Hz-5%-IP00

谐波滤波器 型号 Harmonic filter type	额定负荷功率 [kW] Rated load power	电机驱动输入 电流 [Arms] Motor drive input current	额定滤波器输入 电流[Arms] Rated filter input current	重量 [kg] weight	毛重 [kg] Gross weight	典型损耗 [W] Typical loss	适配电缆 [m ²] Adapter cable	机型 model
HFR005M4SA075C99	75	150	111	118	177	750	99	H6
HFR005M4SA090C99	90	180	134	135	202.5	850	99	H6
HFR005M4SA110C99	110	210	164	158	237	950	99	H6
HFR005M4SA132C99	132	260	197	245.8	318.7	1050	99	H7
HFR005M4SA160C99	160	320	240	328.5	492.75	1300	99	H7
HFR005M4SA200C99	185-200	400	296	373	559.5	1500	99	H8
HFR005M4SA250C99	220-250	480	356	418.5	627.75	1750	99	H9
HFR005M4SA315C99	285-315	600	444	450	675	2150	99	H10
HFR005M4SA355C99	355	670	500	500	750	2350	99	H11

谐波滤波器C系列 380-415V-50Hz-10%-IP20 Harmonic filter C series 380-415V-50Hz-10%-IP20

谐波滤波器 型号 Harmonic filter type	额定负荷功率 [kW] Rated load power	电机驱动输入 电流 [Arms] Motor drive input current	额定滤波器输入 电流[Arms] Rated filter input current	重量 [kg] weight	毛重 [kg] Gross weight	典型损耗 [W] Typical loss	适配电缆 [m ²] Adapter cable	机型 model
HFR010X4SC001C06	0.4-1.5	1-3.7	0.5-2.2	10	17.5	29.5	06	H1
HFR010X4SC002C06	2.2	5.5	3.28	13	19.5	40.5	06	H1
HFR010X4SC005C06	3.7-5.5	10-13	8.2	18	27	67.5	06	H1
HFR010X4SC007C06	7.5	16	11.2	23.4	35.1	90	06	H1
HFR010X4SA011C10	11	24	16.5	31.5	47.25	112.5	10	H1
HFR010X4SA015C10	15	30	22.5	40.5	60.75	202.5	10	H2
HFR010X4SA022C16	18.5-22	44	32.5	46.8	70.2	270	16	H2
HFR010X4SA030C16	30	60	44.5	56.7	85.05	324	16	H3
HFR010X4SA037C35	37	75	54.8	63	94.5	378	35	H3
HFR010X4SA045C35	45	90	66.8	79.2	118.8	423	35	H3
HFR010X4SA055C50	55	110	81.8	92.7	139.05	504	50	H3
HFR010X4SA075C99	75	150	111	106.2	159.3	675	99	H4
HFR010X4SA090C99	90	180	134	135	202.5	765	99	H4
HFR010X4SA110C99	110	210	164	142.3	213.45	855	99	H4
HFR010X4SA132C99	132	260	197	245.8	318.7	1050	99	H5
HFR010X4SA160C99	160	320	240	328.5	492.75	1300	99	H5

谐波滤波器C系列 380-415V-50Hz-10%-IP00 Harmonic filter C series 380-415V-50Hz-10%-IP00

谐波滤波器 型号 Harmonic filter type	额定负荷功率 [kW] Rated load power	电机驱动输入 电流 [Arms] Motor drive input current	额定滤波器输入 电流[Arms] Rated filter input current	净重 [kg] Net weight	毛重 [kg] Gross weight	典型损耗 [W] Typical loss	适配电缆 [m ²] Adapter cable	机型 model
HFR010M4SA075C99	75	150	111	106.2	159.3	675	99	H6
HFR010M4SA090C99	90	180	134	135	202.5	765	99	H6
HFR010M4SA110C99	110	210	164	142.3	213.45	855	99	H6
HFR010M4SA132C99	132	260	197	245.8	318.7	1050	99	H7
HFR010M4SA160C99	160	320	240	328.5	492.75	1300	99	H7
HFR010M4SA200C99	185-200	400	296	373	559.5	1500	99	H8
HFR010M4SA250C99	220-250	480	356	418.5	627.75	1750	99	H9
HFR010M4SA315C99	285-315	600	444	450	675	2150	99	H10
HFR010M4SA355C99	355	670	500	500	750	2350	99	H11

谐波滤波器C系列 440-500V-50Hz-5%-IP20 Harmonic filter C series 440-500V-50Hz-5%-IP20

谐波滤波器 型号 Harmonic filter type	额定负荷功率@ [kW] Rated load power	净重 [kg] Net weight	毛重 [kg] Gross weight	典型损耗 @25°C/50Hz [W] Typical loss	适配电缆 [m ²] Adapter cable	机型 model
HFR005X5SC001C06	0.4-1.5	10	17.5	29.5	06	H1
HFR005X5SC002C06	2.2	14.5	21.75	45	06	H1
HFR005X5SC004C06	3.7	18.5	27.75	68	06	H1
HFR005X5SC005C06	5.5	20	30	75	06	H1
HFR005X5SC007C06	7.5	26	39	100	06	H1
HFR005X5SA011C06	11	35	52.5	125	06	H1
HFR005X5SA015C06	15	45	67.5	225	06	H2
HFR005X5SA022C10	18.5-22	52	78	300	10	H2
HFR005X5SA030C10	30	63	94.5	360	10	H3
HFR005X5SA037C10	37	70	105	420	10	H3
HFR005X5SA045C16	45	88	132	470	16	H3
HFR005X5SA055C35	55	103	154.5	560	35	H3
HFR005X5SA075C35	75	118	177	750	35	H4
HFR005X5SA090C50	90	135	202.5	850	50	H4
HFR005X5SA110C50	110	158	237	950	50	H4
HFR005X5SA132C75	132	245.8	318.7	1050	75	H5
HFR005X5SA160C95	160	328.5	492.75	1300	95	H5

谐波滤波器C系列 440-500V-50Hz-5%-IP00 Harmonic filter C series 440-500V-50Hz-5%-IP00

谐波滤波器 型号 Harmonic filter type	额定负荷功率@ [kW] Rated load power	净重 [kg] Net weight	毛重 [kg] Gross weight	典型损耗 @25°C/50Hz [W] Typical loss	适配电缆 [m ²] Adapter cable	机型 model
HFR005M5SA075C35	75	118	177	750	35	H6
HFR005M5SA090C50	90	135	202.5	850	50	H6
HFR005M5SA110C50	110	158	237	950	50	H6
HFR005M5SA132C75	132	245.8	318.7	1050	75	H7
HFR005M5SA160C95	160	328.5	492.75	1300	95	H7
HFR005M5SA200C99	185-200	373	559.5	1500	99	H8
HFR005M5SA250C99	220-250	418.5	627.75	1750	99	H9
HFR005M5SA315C99	285-315	480	720	2000	99	H10
HFR005M5SA355C99	355-385	520	780	2500	99	H11

谐波滤波器C系列 440-500V-50Hz-10%-IP00 Harmonic filter C series 440-500V-50Hz-10%-IP00

谐波滤波器 型号 Harmonic filter type	额定负荷功率@ [kW] Rated load power	净重 [kg] Net weight	毛重 [kg] Gross weight	典型损耗 @25°C/50Hz [W] Typical loss	适配电缆 [m ²] Adapter cable	机型 model
HFR010M5SA075C35	75	106.2	159.3	675	35	H6
HFR010M5SA090C50	90	12.5	18.75	765	50	H6
HFR010M5SA110C50	110	142.3	213.45	855	50	H6
HFR010M5SA132C75	132	145.8	218.7	1050	75	H7
HFR010M5SA160C95	160	328.5	492.75	1300	95	H7
HFR010M5SA200C99	185-200	373	559.5	1500	99	H8
HFR010M5SA250C99	220-250	418.5	627.75	1750	99	H9
HFR010M5SA315C99	285-315	480	720	2000	99	H10
HFR010M5SA355C99	355-385	520	780	2500	99	H11

谐波滤波器C系列 380-415V-60Hz-5%-IP20 Harmonic filter C series 380-415V-60Hz-5%-IP20

谐波滤波器型号 Harmonic filter type	额定负荷功率 Rated load power [KW]	电机驱动输入 电流[A rms]	额定滤波器输入 电流[A rms]	净重 [kg]	毛重 [kg]	典型损耗 [W]	适配电缆 [m ²]	机型 model
HFR105X4SC001C06	0.4-1.5	1-3.7	0.5-2.2	10	17	29.5	06	H1
HFR105X4SC002C06	2.2	7	5	14.5	21.75	88	06	H1
HFR105X4SC005C06	3.7-5.5	14	10.5	20	30	115	06	H1
HFR105X4SC007C06	7.5	21	14.4	26	39	185	06	H1
HFR105X4SA011C10	11	27-34	12	35	52.5	225	10	H1
HFR105X4SA015C10	15	44	29	45	67.5	285	10	H2
HFR105X4SA022C16	22	52-66	40	52	78	300	16	H2
HFR105X4SA030C16	30	83	55	63	94.5	450	16	H3
HFR105X4SA037C35	37	103	66	70	105	650	35	H3
HFR105X4SA055C50	55	128	96	103	154.5	850	50	H3
HFR105X4SA075C99	75	165	150	118	177	950	99	H4
HFR105X4SA090C99	90	208	180	135	202.5	1050	99	H4
HFR105X4SA110C99	110	240	217	158	237	1250	99	H4
HFR105X4SA132C99	132	320	259	205	315	1380	99	H5
HFR105X4SA160C99	160	403	290	265	397.5	1540	99	H5

谐波滤波器C系列 380-415V-60Hz-5%-IP00 Harmonic filter C series 380-415V-60Hz-5%-IP00

谐波滤波器型号 Harmonic filter type	额定负荷功率 Rated load power [KW]	电机驱动输入 电流[A rms]	额定滤波器输入 电流[A rms]	净重 [kg]	毛重 [kg]	典型损耗 [W]	适配电缆 [m ²]	机型 model
HFR105M4SA075C99	75	165	150	118	177	950	99	H6
HFR105M4SA090C99	90	208	180	135	202.5	1050	99	H6
HFR105M4SA110C99	110	240	217	158	237	1250	99	H6
HFR105M4SA132C99	132	320	259	205	315	1380	99	H7
HFR105M4SA160C99	160	403	290	265	397.5	1540	99	H7
HFR105M4SA200C99	200	495	370	305	457.5	1817	99	H8
HFR105M4SA250C99	250	610	520	350	525	2144	99	H9
HFR105M4SA315C99	315	759	580	403	604.5	2530	99	H10
HFR105M4SA355C99	355	820	650	425	637.5	2850	99	H11

谐波滤波器C系列 380-415V-60Hz-10%-IP20 Harmonic filter C series 380-415V-60Hz-10%-IP20

谐波滤波器型号 Harmonic filter type	额定负荷功率 Rated load power [KW]	电机驱动输入 电流[A rms]	额定滤波器输入 电流[A rms]	净重 [kg]	毛重 [kg]	典型损耗 [W]	适配电缆 [m ²]	机型 model
HFR110X4SC001C06	0.4-1.5	1-3.7	0.5-2.2	10	17	29.5	06	H1
HFR110X4SC002C06	2.2	7	5	12.5	18.75	80	06	H1
HFR110X4SC005C06	3.7-5.5	14	10.5	18	27	105	06	H1
HFR110X4SC007C06	7.5	21	14.4	23.5	35.25	172	06	H1
HFR110X4SA011C10	11	27-34	12	32	48	210	10	H1
HFR110X4SA015C10	15	44	29	41.5	62.25	255	10	H2
HFR110X4SA022C16	22	52-66	40	48.5	72.75	280	16	H2
HFR110X4SA030C16	30	83	55	59	88.5	395	16	H3
HFR110X4SA037C35	37	103	66	65	97.5	580	35	H3
HFR110X4SA055C50	55	128	96	96	144	760	50	H3
HFR110X4SA075C99	75	165	150	108	162	880	99	H4
HFR110X4SA090C99	90	208	180	118	177	965	99	H4
HFR110X4SA110C99	110	240	217	142	213	1050	99	H4
HFR110X4SA132C99	132	320	259	150	225	1380	99	H5
HFR110X4SA160C99	160	403	290	265	397.5	1540	99	H5

谐波滤波器C系列 380-415V-60Hz-10%-IP00 Harmonic filter C series 380-415V-60Hz-10%-IP00

谐波滤波器型号 Harmonic filter type	额定负荷功率 Rated load power [KW]	电机驱动输入 电流[A rms]	额定滤波器输入 电流[A rms]	净重 [kg]	毛重 [kg]	典型损耗 [W]	适配电缆 [m ²]	机型 model
HFR110M4SA075C99	75	165	150	108	162	880	99	H6
HFR110M4SA090C99	90	208	180	118	177	965	99	H6
HFR110M4SA110C99	110	240	217	142	213	1050	99	H6
HFR110M4SA132C99	132	320	259	150	225	1380	99	H7
HFR110M4SA160C99	160	403	290	265	397.5	1540	99	H7
HFR110M4SA200C99	200	495	370	305	457.5	1817	99	H8
HFR110M4SA250C99	250	610	520	350	525	2144	99	H9
HFR110M4SA315C99	315	759	580	403	604.5	2530	99	H10
HFR110M4SA355C99	355	820	650	425	637.5	2850	99	H11

谐波滤波器C系列 440-500V-60Hz-5%-IP20 Harmonic filter C series 440-500V-60Hz-5%-IP20

谐波滤波器型号 Harmonic filter type	额定负荷功率 Rated load power [KW]	电机驱动输入 电流[A rms]	额定滤波器输入 电流[A rms]	净重 [kg]	毛重 [kg]	典型损耗 [W]	适配电缆 [m ²]	机型 model
HFR105X5SC001C06	0.4-1.5	1-3.7	0.5-2.2	10	17	29.5	06	H1
HFR105X5SC002C06	2.2	7	5	14.5	21.75	88	06	H1
HFR105X5SC005C06	3.7-5.5	14	10.5	20	30	115	06	H1
HFR105X5SC007C06	7.5	21	14.4	23	36	165	06	H1
HFR105X5SC011C06	11	27-34	12	26	39	185	06	H1
HFR105X5SC015C06	15	44	29	35	52.5	225	06	H2
HFR105X5SA022C06	22	52-66	40	45	67.5	285	06	H2
HFR105X5SA030C10	30	83	55	52	78	300	10	H3
HFR105X5SA037C10	37	103	66	63	94.5	450	10	H3
HFR105X5SA045C16	45	115	80	70	105	650	16	H3
HFR105X5SA055C35	55	128	96	103	154.5	850	35	H4
HFR105X5SA075C35	75	165	150	118	177	950	35	H4
HFR105X5SA090C50	90	208	180	135	202.5	1050	50	H4
HFR105X5SA110C50	110	240	217	139	208.5	1050	50	H4
HFR105X5SA132C75	132	320	259	175	262.5	1380	75	H5
HFR105X5SA160C95	160	403	290	230	345	1540	95	H5

谐波滤波器C系列 440-500V-60Hz-5%-IP00 Harmonic filter C series 440-500V-60Hz-5%-IP00

谐波滤波器型号 Harmonic filter type	额定负荷功率@ Rated load power [KW]	电机驱动输入 电流[A rms]	额定滤波器输入 电流[A rms]	净重 [kg]	毛重 [kg]	典型损耗 [W]	适配电缆 [m ²]	机型 model
HFR105M5SA075C35	75	165	150	118	177	950	35	H6
HFR105M5SA090C35	90	208	180	135	202.5	1050	35	H6
HFR105M5SA110C75	110	240	217	139	208.5	1050	75	H6
HFR105M5SA132C75	132	320	259	175	262.5	1380	75	H7
HFR105M5SA160C95	160	403	290	230	345	1540	95	H7
HFR105M5SA200C99	200	495	370	260	390	1817	99	H8
HFR105M5SA250C99	250	610	520	315	472.5	2144	99	H9
HFR105M5SA315C99	315	759	580	345	517.5	2530	99	H10
HFR105M5SA355C99	355	820	650	385	577.5	2950	99	H11

谐波滤波器C系列 440-500V-60Hz-10%-IP20 Harmonic filter C series 440-500V-60Hz-10%-IP20

谐波滤波器型号 Harmonic filter type	额定负荷功率@ Rated load power [KW]	电机驱动输入 电流[A rms] Motor drive input current	额定滤波器输入 电流[A rms] Rated filter input current	净重 [kg] Net weight	毛重 [kg] Gross weight	典型损耗 [W] Typical loss	适配电缆 [m ²] Adapter cable	机型 model
HFR110X5SC001C06	0.4-1.5	1-3.7	0.5-2.2	10	17	29.5	06	H1
HFR110X5SC004C06	2.2	7	5	14.5	21.75	88	06	H1
HFR110X5SC005C06	3.7-5.5	14	10.5	20	30	115	06	H1
HFR110X5SC007C06	7.5	21	14.4	26	39	135	06	H1
HFR110X5SC011C06	11	27-34	12	28.5	43.75	165	06	H1
HFR110X5SC015C06	15	44	29	32.5	48.75	108	06	H2
HFR110X5SA022C06	22	52-66	40	41	61.5	162	06	H2
HFR110X5SA030C06	30	83	55	47.5	71.25	275	06	H3
HFR110X5SA037C10	37	103	66	58.5	87.75	415	10	H3
HFR110X5SA045C10	45	115	80	66	99	620	10	H3
HFR110X5SA055C10	55	128	96	95	142.5	815	10	H4
HFR110X5SA075C35	75	165	150	106	159	905	35	H4
HFR110X5SA090C50	90	208	180	118	177	980	50	H4
HFR110X5SA110C50	110	240	217	139	208.5	1050	50	H4
HFR110X5SA132C75	132	320	259	175	262.5	1380	75	H5
HFR110X5SA160C95	160	403	290	230	345	1540	95	H5

谐波滤波器C系列 440-500V-60Hz-10%-IP00 Harmonic filter C series 440-500V-60Hz-10%-IP00

谐波滤波器型号 Harmonic filter type	额定负荷功率 Rated load power [KW]	电机驱动输入 电流[A rms] Motor drive input current	额定滤波器输入 电流[A rms] Rated filter input current	净重 [kg] Net weight	毛重 [kg] Gross weight	典型损耗 [W] Typical loss	适配电缆 [m ²] Adapter cable	机型 model
HFR110M5SA075C35	75	165	150	106	159	905	35	H6
HFR110M5SA090C50	90	208	180	118	177	980	50	H6
HFR110M5SA110C50	110	240	217	139	208.5	1050	50	H6
HFR110M5SA132C75	132	320	259	175	262.5	1380	75	H7
HFR110M5SA160C95	160	403	290	230	345	1540	95	H7
HFR110M5SA200C99	200	495	370	260	390	1817	99	H8
HFR110M5SA250C99	250	610	520	315	472.5	2144	99	H9
HFR110M5SA315C99	315	759	580	345	517.5	2530	99	H10
HFR110M5SA355C99	355	820	650	385	577.5	2950	99	H11

产品尺寸图 (Product Dimension Drawing)

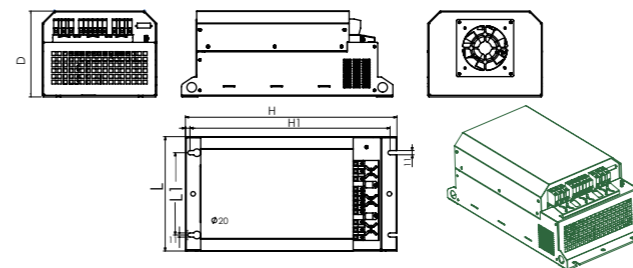

H1/H2/H3

机型 model	尺寸Size (±2mm)					
	L	D	H	L1	H1	A/B
H1	300	230	555	216	525	11*18
H2	410	275	650	350	640	11*15
H3	410	380	700	350	660	11*15

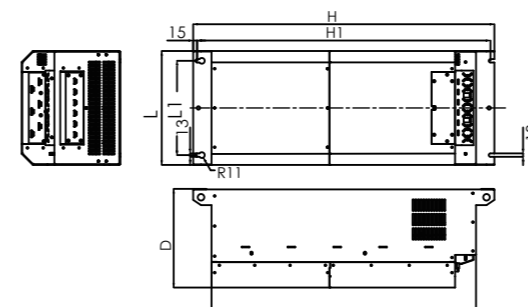

H4

机型 model	尺寸Size (±2mm)					
	L	D	H	L1	H1	A/B
H4	435	377	1150	360	1120	13*20

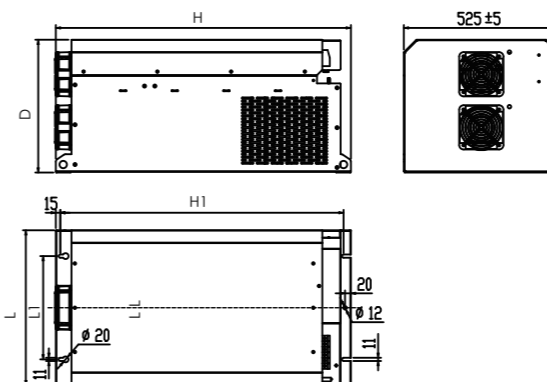

H5

机型 model	尺寸Size (±2mm)					
	L	D	H	L1	H1	A/B
H5	525	450	1000	350	960	11*20

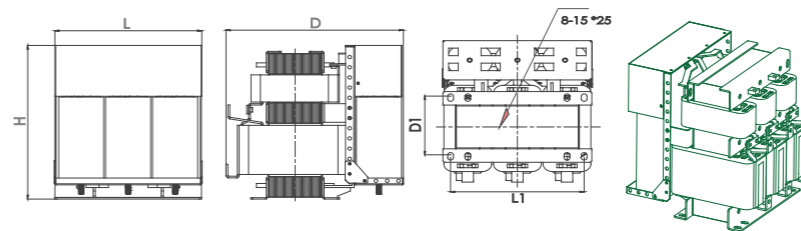

H6/H7/H8/H9

机型 model	尺寸Size (max)					
	L	D	H	L1	D1	A/B
H6	400	490	460	350/260	206	15*25
H7	430	570	735	380	202	12*40
H8	520	570	800	461	164	12*40
H9	520	575	840	461	184	12*40
H10	520	600	840	461	224	12*40
H11	520	615	840	461	224	12*40

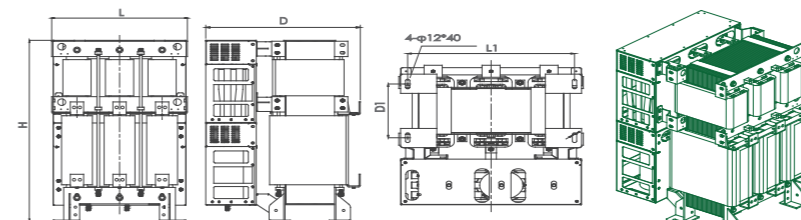

H10/H11

谐波滤波器 B系列 380-415V-50Hz-5%-IP20 Harmonic filter Series B 380-415V-50Hz-5%-IP20

谐波滤波器型号 Harmonic filter type	额定负荷功率 Rated load power [kW]	电机驱动输入 电流 [Arms] Motor drive input current	额定滤波器输入 电流 [Arms] Rated filter input current	净重 [kg] Net weight	毛重 [kg] Gross weight	典型损耗 [W] Typical loss	适配电缆 [m ²] Adapter cable	机型 model
HFR005X4SC001B06	0.4-1.5	1-3.7	0.5-2.2	10	17.5	29.5	06	H1
HFR005X4SC002B06	2.2	5	3.28	23	34.5	45	06	H1
HFR005X4SC005B06	3.7-5.5	10.5	8.2	30	37.5	75	06	H1
HFR005X4SC007B06	7.5	14.4	11.2	40	45	100	06	H1
HFR005X4SA011B10	11	22	16.5	50	60	125	10	H1
HFR005X4SA015B10	15	29	22.5	60	75	225	10	H2
HFR005X4SA022B16	18.5-22	40	32.5	60	90	300	16	H2
HFR005X4SA030B16	30	55	44.5	70	105	360	16	H2
HFR005X4SA037B35	37	66	54.8	80	120	420	35	H3
HFR005X4SA045B35	45	80	66.8	100	150	470	35	H3
HFR005X4SA055B50	55	96	81.8	110	165	560	50	H3
HFR005X4SA075B99	75	150	111	110	165	750	99	H4
HFR005X4SA090B99	90	180	134	120	180	850	99	H4
HFR005X4SA110B99	110	217	164	130	195	950	99	H4

谐波滤波器 B系列 380-415V-50Hz-5%-IP20 Harmonic filter Series B 380-415V-50Hz-5%-IP20

谐波滤波器型号 Harmonic filter type	额定负荷功率 Rated load power [kW]	电机驱动输入 电流 [Arms] Motor drive input current	额定滤波器输入 电流 [Arms] Rated filter input current	净重 [kg] Net weight	毛重 [kg] Gross weight	典型损耗 [W] Typical loss	适配电缆 [m ²] Adapter cable	机型 model
HFR010X4SC001B06	0.4-1.5	1-3.7	0.5-2.2	10	17.5	29.5	06	H1
HFR010X4SC002B06	2.2	5	3.28	23	34.5	45	06	H1
HFR010X4SC005B06	3.7-5.5	10.5	8.2	30	37.5	75	06	H1
HFR010X4SC007B06	7.5	14.4	11.2	40	45	100	06	H1
HFR010X4SA011B10	11	22	16.5	50	60	125	10	H1
HFR010X4SA015B10	15	29	22.5	60	75	225	10	H2
HFR010X4SA022B16	18.5-22	40	32.5	60	90	300	16	H2
HFR010X4SA030B16	30	55	44.5	70	105	360	16	H2
HFR010X4SA037B35	37	66	54.8	80	120	420	35	H3
HFR010X4SA045B35	45	80	66.8	100	150	470	35	H3
HFR010X4SA055B50	55	96	81.8	110	165	560	50	H3
HFR010X4SA075B99	75	150	111	110	165	750	99	H4
HFR010X4SA090B99	90	180	134	120	180	850	99	H4
HFR010X4SA110B99	110	217	164	130	195	950	99	H4

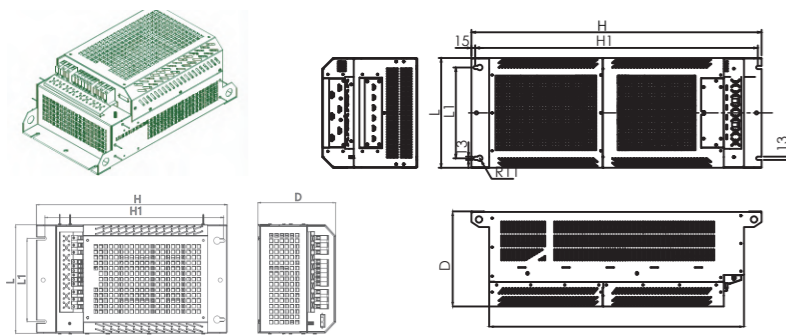

H1/H2/H3

H4

机型 model	尺寸Size (max)					
	L	D	H	L1	H1	A/B
H1	300	230	555	216	525	11*18
H2	410	275	650	350	640	11*15
H3	410	380	700	350	660	11*15
H4	450	390	1160	360	1120	11*15

谐波滤波器 N系列 380-415V-50Hz-5%-IP20 Harmonic filter Series B 380-415V-50Hz-5%-IP20

谐波滤波器型号 Harmonic filter type	额定负荷功率 Rated load power [kW]	电机驱动输入 电流 [Arms] Motor drive input current	额定滤波器输入 电流 [Arms] Rated filter input current	净重 [kg] Net weight	毛重 [kg] Gross weight	典型损耗 [W] Typical loss	适配电缆 [m ²] Adapter cable	机型 model
HFR005X4SC001N06	0.4-1.5	1-3.7	0.5-2.2	10	17.5	29.5	06	H1
HFR005X4SC002N06	2.2	5	3.28	23	34.5	45	06	H1
HFR005X4SC005N06	3.7-5.5	11	8.2	22	33	45	06	H1
HFR005X4SC007N06	7.5	15	11.2	28	42	75	06	H1
HFR005X4SC011N10	11	22	16.5	38	57	100	10	H2
HFR005X4SA015N10	15	30	22.5	48	72	125	10	H3
HFR005X4SA022N16	18.5-22	45	32.5	55	82.5	225	16	H4
HFR005X4SA030N16	30	60	44.5	66	99	300	16	H4
HFR005X4SA037N35	37	80	54.8	72	108	360	35	H4
HFR005X4SA045N35	45	90	66.8	93	139.5	420	35	H5
HFR005X4SA055N50	55	110	81.8	112	168	470	50	H6
HFR005X4SA075N99	75壁挂	150	111	125	187.5	560	99	H7
HFR005X4SA090N99	90壁挂	180	134	145	217.5	750	99	H8
HFR005X4SA110N99	110壁挂	217	164	165	247.5	850	99	H9
HFR005X4SA132N99	132壁挂	259	197	175	262.5	950	99	H10
HFR005X4SA160N99	160	290	240	385	577.5	1300	99	H11
HFR005X4SA200N99	200	370	296	430	645	1500	99	H11
HFR005X4SA250N99	220/250	520	356	485	727.5	1750	99	H11
HFR005X4SA315N99	315	580	444	520	780	2150	99	H11
HFR005X4SA355N99	355	650	500	570	855	2350	99	H11

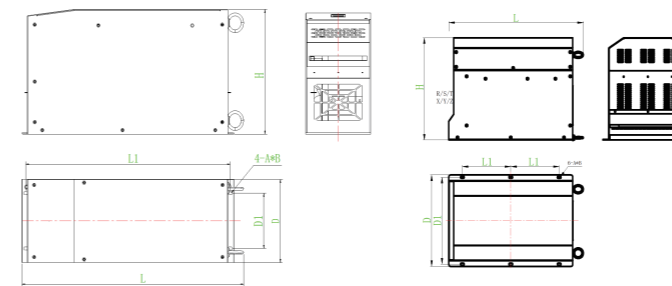

H1/H2/H3/H4/H5/H6

H7/H8/H9/H10



H11

机型 model	尺寸Size (max)					
	L	D	H	L1+2	D1+2	A/B
H1	415	235	215	355	165	φ16φ9
H2	460	265	270	390	200	φ16φ9
H3	585	340	355	490	270	φ16φ9
H4	715	245	350	650	150	φ16φ9
H5	750	330	370	675	150	φ16φ9
H6	750	330	370	675	150	6-10*20
H7	750	475	530	275*2	445	6-10*20
H8	750	475	580	275*2	445	6-10*20
H9	750	475	600	275*2	445	6-10*20
H10	750	475	600	275*2	445	4-φ13
H11	600	600	2200	535	525	4-φ13

dv/dt滤波器 (VTR) dv/dt Filter



产品概述 (Product Introduction)

PWM逆变器直接驱动电机时会产生较高dv/dt的共模电压,并由此产生轴承电流和共模漏电流以及严重的电磁干扰(EMI).特别是当逆变器通过长线电缆与电机连接时,由于电缆中分布参数的影响,会在电机端产生电压反射现象,从而在电机端会产生2倍以上的过电压,导致线圈绝缘失败.dv/dt滤波器降低电机电缆传输线效应电压的增大而衰减率,并最大限度地减少在电机端子上所发生的峰值电压。

When the PWM inverter will produce high common-mode voltage of dv/dt when directly driving the motor, resulting in bearing current and common-mode leakage current as well as severe electromagnetic interference (EMI). Especially when the inverter is connected to the motor with a long cable, the influence of the distribution parameters of the cable will result in voltage reflection, which will produce over-voltage of over two times at the motor terminal, causing failure of the coil insulation. However, dv/dt filters can reduce the rate of decay due to increase of the effect voltage during transmission of the motor cable, and minimize the peak voltage generated at the motor terminal.

产品应用 (Product Application)

dv/dt滤波器是设计用于保护电机的滤波器,由于变频器与电机之间运行电缆过长会引起对电机产生毁灭性影响峰值电压。电缆的长度取决于用在变频器中的电力半导体的开关次数和电机的大小,如果电缆短到2.5米则会导致电机承受的峰值电压超过电机绝缘系统的额定值。然而,如果电缆太长则问题更大,在这种情况下就需要用dv/dt滤波器来保护电机不受峰值电压的毁灭性影响。

The dv/dt filters are designed to protect the motor filter as peak voltage disastrous to the motor will be generated if the cable between the inverter and the motor is too long. The cable length depends on the switching times of the power semiconductor in the inverter and the size of the motor. A cable as short as 2.5m will result in peak voltage of the motor exceeding the rated value of the motor insulation system. However, the problem is even greater if the cable is too long, in which case you need to use a dv/dt filter to protect the motor from the devastating impact of the peak voltage.

技术规格 (Technical Specifications)

- 1.最大工作电压 Work Voltage: 400V AC-1140V AC
- 2.额定电流 Work Current: 5~500A
- 3.频率 Work Frequency: 50-60Hz
- 4.开关频率 Switching frequency: 2~8KHz
- 5.防护等级 Protection class: IP00-IP20
- 6.绝缘等级 Insulation Class: class F,H
- 7.使用环境: -10~+45 °C,额定值不会降低。最高可达+55°C,在45°C以上,每升高1°C,额定电流降低2%
Operation Environment:-10~+45 °C, rated value wont Up to+55 °C, above 45 °C, for every 1 °C increase, the rated current decreases by 2%
- 8.最大电缆长度 Maximum cable length: 1000m
- 9.最大电流 Max Current: 1.5×额定电流,持续60S 1.5 × Rated current,continuous 60S
- 10.噪音 Noise: ≤65dB
- 11.温升 Temperature Rise: ≤85K
- 12.抗电强度: 铁芯-绕组 3000VAC/50Hz/5mA/10s无飞弧击穿(工厂测试)
Dielectric strength: Core Coil 3000VAC/50Hz/5mA/10s no electric arcing puncture (factory test)
- 13.绝缘电阻 Insulation Resistor: 1000VDC insulation resistance value ≥ 100MΩ
- 14.海拔高度不超过2000米。Under seal level 2000m
- 15.运行环境温度-25°C~+45°C,相对湿度不超过90%。
Running ambient temperature -25 °C ~ +45 °C, comparative moisture not over 90%.
- 16.周围无有害气体,无易燃易爆物品。No hazardous gas, no inflammables and explosives
- 17.周围环境应有良好的通风条件,如装在柜内,应加装通风设备。
With well-ventilated condition, ventilation devices shall be mounted if installtioh in panels

典型电路图 (Typical circuit diagram)

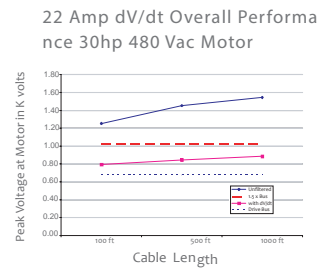
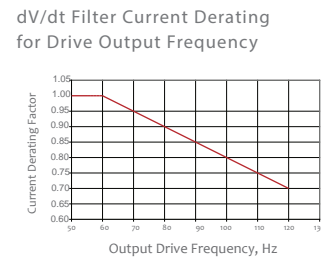
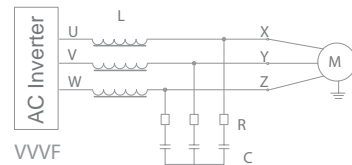

执行标准 (Applicable Standards)

IEC289: 1987 Reactor
GB10229-88 Reactor (eqvIEC289: 1987)
JB9644-1999 Reactors used for semiconductor electrical driving

1000 ft Full Load, 8kHz Switching, Unfiltered Shielded Cable

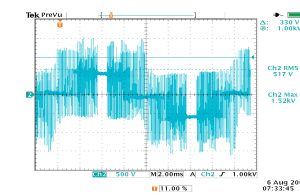

1000 ft Full Load, 8kHz Switching with dV/dt Filter

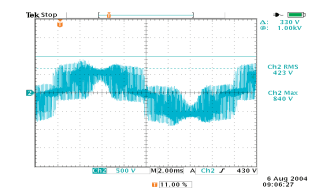

产品尺寸图 (Product Size)

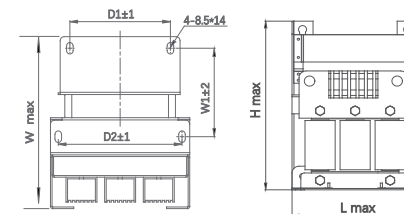

Picture A

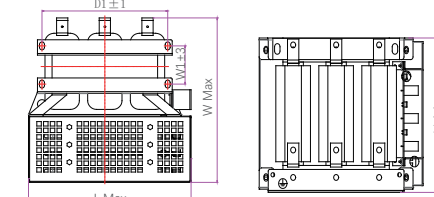

Picture B

380V 滤波器型号 TYPE	适配功率 Power(kw)	图号 Picture NO.	额定电流 Rated Current (A)	绝缘等级 Insulation Class	尺寸 Dimension(±5mm)						
					L(max)	W(max)	H(max)	W1±2	D1±2	D2±2	A*B
VTR-0005-0.4SC	2.2		5	F,H	200	235	270	68	55/95	160	8.5*14/6*15
VTR-0010-0.4SC	3.7-4.5		10	F,H	200	235	270	68	55/95	160	8.5*14/6*15
VTR-0015-0.4SC	5.5		15	F,H	200	240	270	104	130	160	8.5*14
VTR-0020-0.4SC	7.5		20	F,H	200	240	270	120	130	160	8.5*14
VTR-0030-0.4SA	11	图 A	30	F,H	240	240	320	115	150	200	8.5*14
VTR-0040-0.4SA	15	Picture A	40	F,H	240	250	320	135	150	200	8.5*14
VTR-0050-0.4SA	18.5		50	F,H	240	260	325	135	150	200	8.5*14
VTR-0060-0.4SA	22		60	F,H	240	260	330	143	150	200	8.5*14
VTR-0080-0.4SA-YT	30		80	F,H	355	370	255	73	245	245	11*18
VTR-0090-0.4SA-YT	37		90	F,H	355	370	255	73	245	245	11*18
VTR-0120-0.4SA-YT	45		120	F,H	390	385	230	83	280	280	11*18
VTR-0150-0.4SA-YT	55		150	F,H	390	400	285	103	280	280	11*18
VTR-0200-0.4SA-YT	75		200	F,H	390	385	285	87	280	280	11*18
VTR-0250-0.4SA-YT	90/110		250	F,H	370	385	300	87	280	280	11*18
VTR-0290-0.4SA-YT	132	图 B	290	F,H	370	385	300	87	280	280	11*18
VTR-0330-0.4SA-YT	160	Picture B	330	F,H	440	400	300	97	280	280	11*18
VTR-0390-0.4SA-YT	185		390	F,H	440	410	300	107	280	280	11*18
VTR-0490-0.4SA-YT	220/250		490	F,H	370	410	400	97	280	280	11*18

备注: 其他规格尺寸, 可根据用户要求制造。Remark: Dimension can be customization

成品识别码 (Product Identification Code)

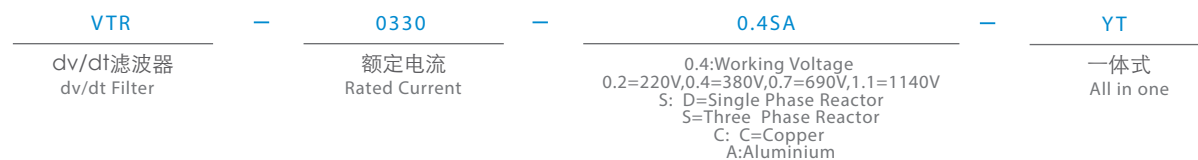

690V滤波器型号 reactor Type	适配功率 Power (KW)	图号 Picture NO.	额定电流 Rated Current (A)	绝缘等级 Insulation Class	尺寸 Dimension					
					L(max)	W(max)	H(max)	W1±2	D±2	A*B
VTR-0080-0.7SA	75		80	F	330	290	410	200	280	11*18
VTR-0090-0.7SA	90		90	F	330	290	410	200	280	11*18
VTR-0120-0.7SA	110		120	F	380	340	400	250	330	11*18
VTR-0150-0.7SA	132		150	F	340	390	420	250	265	12*20
VTR-0215-0.7SA	160-200		215	F	340	390	450	250	265	12*20
VTR-0250-0.7SA	220		250	F	350	390	460	250	280	12*20
VTR-0330-0.7SA	250-300		330	F	350	400	500	250	280	12*20
VTR-0390-0.7SA	315-380	图B	390	F	370	390	480	250	300	12*20
VTR-0410-0.7SA	400		410	F	420	445	520	320	350	15*25
VTR-0490-0.7SA	450		575	F	460	445	520	320	390	15*25
VTR-0575-0.7SA	560		575	F	460	445	550	320	390	15*25
VTR-0810-0.7SA	710-800		810	F	510	485	560	320	430	15*25
VTR-1000-0.7SA	900-1000		1000	F						15*25
VTR-1200-0.7SA	1100-1200		1200	F						15*25
VTR-1400-0.7SA	1300-1400		1400	F						15*25

Cabinet structure 柜机结构

最大电缆长度 Maximum cable length: 300m内, 非屏蔽. Within 300m, unshielded

产品尺寸图 (Product Size)

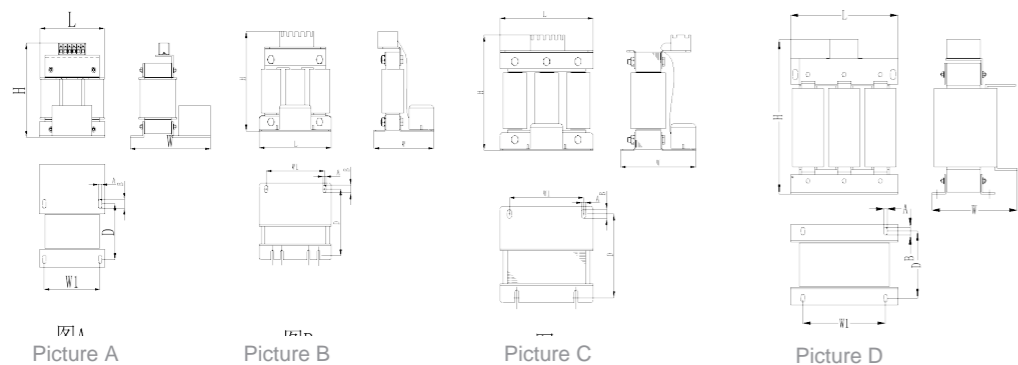

380-480VDUDT滤波器(T1) 380-480VDUDT Filter (T1)

型号 TYPE	材质 material	适配功率 Power(kw)	图号 Picture NO.	额定电流 Rated Current (A)	绝缘等级 Insulation Class	尺寸 Dimension(±5mm)						重量 weight
						L(max)	W(max)	H(max)	W1±2	D1±2	A*B	
VTR-0005-0.4SC(100)	CU铜线	1.1-1.5	图 A	5	F	110	130	130	90	70	6*11	2.3
VTR-0010-0.4SC(100)	CU铜线	2.2-4	Picture A	10	F	110	130	135	90	70	6*11	2.5
VTR-0020-0.4SC(100)	CU铜线	5.5-7.5		20	F	110	130	130	90	70	6*11	2.65
VTR-0030-0.4SC(100)	CU铜线	11	图 B	30	F	155	155	170	120	100	6*12	3.4
VTR-0040-0.4SC(100)	CU铜线	15	Picture B	40	F	155	155	170	120	100	6*12	3.6
VTR-0050-0.4SC(100)	CU铜线	15-22		50	F	155	165	170	120	110	6*12	5.2
VTR-0075-0.4SA(100)	AL线	30	图 C	75	F	190	165	205	150	130	8.5*14	8
VTR-0110-0.4SA(100)	AL线	37-45	Picture C	110	F	190	190	205	150	150	8.5*14	10
VTR-0200-0.4SA(100)	AL线	75-90		200	F	230	180	275	180	98	11*18	15
VTR-0250-0.4SA(100)	AL线	110		250	F	250	175	270	182	98	11*18	17
VTR-0330-0.4SA(100)	AL线	110-132	图 D	330	F	290	200	320	214	107	11*18	25
VTR-0390-0.4SA(100)	AL线	160-200	Picture D	390	F	290	200	315	214	107	11*18	30
VTR-0490-0.4SA(100)	AL线	250		490	F	290	200	315	214	107	11*18	35
VTR-0800-0.4SA(100)	AL线	315-400		800	F	320	250	385	243	140	11*18	55

最大电缆长度 Maximum cable length: 100m内, 非屏蔽. Within 100m, unshielded

备注: 其他规格尺寸, 可根据用户要求制造. Remark: Dimension can be customization

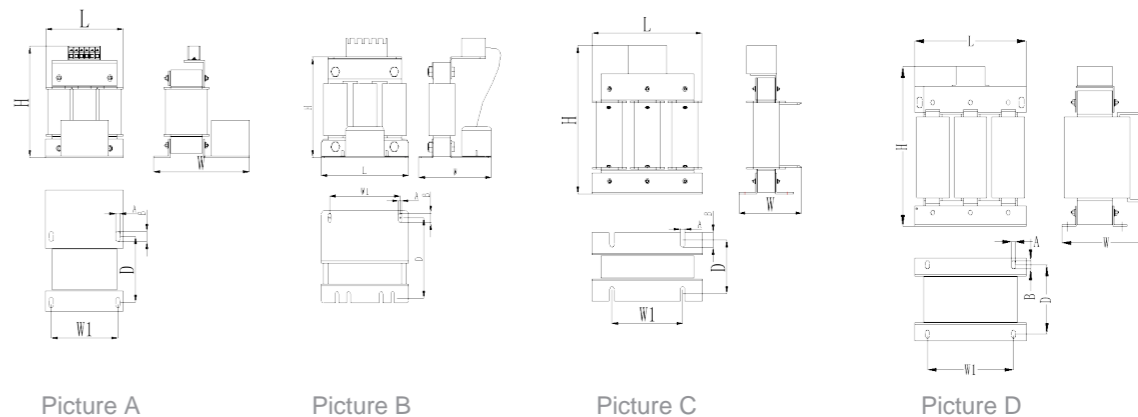

380-480VDUDT滤波器(T2) 380-480VDUDT Filter (T2)

型号 TYPE	材质 material	适配功率 Power(kw)	图号 Picture NO.	额定电流 Rated Current (A)	绝缘等级 Insulation Class	尺寸 Dimension(±5mm)						重量 weight
						L(max)	W(max)	H(max)	W1±2	D1±2	A*B	
VTR-0005-0.4SC (200)	CU铜线	2.2	图 A	5	F	110	140	130	90	70	6*11	3
VTR-0010-0.4SC (200)	CU铜线	3.7-4.5	Picture A	10	F	110	140	135	90	70	6*11	3.8
VTR-0015-0.4SC (200)	CU铜线	5.5	图 B	15	F	155	140	170	120	98	6*12	4.5
VTR-0020-0.4SC (200)	AL线	7.5	Picture B	20	F	155	140	170	120	98	6*12	4.5
VTR-0030-0.4SA (200)	AL线	11		30	F	195	140	220	120	70	8.5*20	10
VTR-0040-0.4SA (200)	AL线	15	图 C	40	F	195	140	220	120	70	8.5*20	10
VTR-0050-0.4SA (200)	AL线	18.5	Picture C	50	F	195	160	220	120	90	8.5*20	11
VTR-0060-0.4SA (200)	AL线	22		60	F	195	160	220	120	90	8.5*20	13
VTR-0080-0.4SA (200)	AL线	30		80	F	195	170	220	120	100	8.5*20	12
VTR-0090-0.4SA (200)	AL线	37		90	F	195	170	220	120	100	8.5*20	12
VTR-0120-0.4SA (200)	AL线	45		120	F	250	225	335	182	118	11*18	27
VTR-0150-0.4SA (200)	AL线	55		150	F	250	225	335	182	118	11*18	28.5
VTR-0200-0.4SA (200)	AL线	75		200	F	250	225	335	182	118	11*18	29.5
VTR-0250-0.4SA (200)	AL线	90/110	图 D	250	F	250	225	335	182	118	11*18	31
VTR-0290-0.4SA (200)	AL线	132		290	F	250	225	335	182	118	11*18	31
VTR-0330-0.4SA (200)	AL线	160	Picture D	330	F	320	210	385	243	114	11*18	38
VTR-0390-0.4SA (200)	AL线	185		390	F	320	230	385	243	134	11*18	38
VTR-0490-0.4SA (200)	AL线	220/250		490	F	320	250	385	243	154	11*18	63

最大电缆长度 Maximum cable length: 200m内, 非屏蔽. Within 200m, unshielded

备注: 其他规格尺寸, 可根据用户要求制造. Remark: Dimension can be customization

正弦波滤波器 (SFR) Sine Wave Filter

■ 产品概述 (Product Introduction)

正弦波滤波器是在PWM变频器驱动下,其开关频率范围在2-8kHz之间仍提供正弦波输出电压。在变频器驱动应用中,这种滤波器可以消除电机绝缘失效问题并通过消除与变频器输出波形相关的高dV/dt来减少电磁干扰,改善电机的性能和寿命,延长变频器输出距离,最长可达3KM。为保护电线电缆,使用正弦波滤波器可防止长引线驱动电机的过电压问题。在其他能源应用下,比如风力发电机,逆变器将电力通过升压变压器还原到实用的配电系统,这种滤波器可以允许使用标准变压器。满载并在60Hz时给变压器输入的谐波电压畸变最大值是5%的话,那么满载时给电机输入的谐波电压畸变一般就是5%。

Driven by the PWM inverter, the sine filter still provides sine wave output voltage when the switching frequency range is within the range of 2-8kHz. In the applications of inverter drives, such a filter can eliminate the problem of motor insulation failure and decrease electromagnetic interference by eliminating the high dV/dt related to inverter output waveform, so as to extend the life and improve the performance of the motor, and extend the output length of the inverter to up to 3KM. For the protection of wires and cables, the sine filter can avoid over-voltage of the drive motor with a long lead. In the application of other energy resources, wind generator, for example, the inverter restores the power to the utility power system through a step-up transformer. And such filters allow the use of a standard transformer. If the maximum value of the harmonic voltage distortion input to the transformer at full load and 60Hz is 5%, the harmonic voltage distortion input to the motor at full load is generally 5%.

■ 产品应用 (Product Application)

- 1.将变频器输出的PWM波转换成为正弦波
- 2.降低电机的涡流损耗以及电机噪声
- 3.减少输出电缆上和电机中的脉冲电流,延长电机寿命
- 4.可在变频器与电机间使用更长的电缆连线
- 5.减小对外的辐射,在一定场合可以使用非屏蔽电缆,降低了对现场布线的要求
- 6.有效防止高DV/DT、过电压、电机过热和涡流损耗造成的电机提前损坏。

1. Convert the PWM waves output by the inverter sine waves
2. Reduce the eddy current losses of the motor and the motor noise
3. Reduce the pulse current of the output cable and motor, extending the life of the motor"
4. A longer cable wire can be used between the inverter and motor
5. Reduce the external radiation, by using unshielded cable in certain situations, lowering the requirements for on-site wiring requirements
6. Effectively prevent fatigue damage of the motor caused by high DV/DT, over voltage, motor overheating and eddy current loss.

■ 技术规格 (Technical Specifications)

1. 工作电压: 220VAC-690VAC
2. 工作电流: 15A-1500A
3. 工作频率: 50/60Hz.
4. 载波频率: 2K-8K
5. 绝缘等级: class F,H
6. 压降: 8%-12%
7. 电压谐波畸变失真THD \leq 5%
8. 空载电流 \leq 8%
9. 使用环境: -10 \cdots +45 $^{\circ}$ C,额定值不会降低。最高可达+55 $^{\circ}$ C,在45 $^{\circ}$ C以上,每升高1 $^{\circ}$ C,额定电流降低2%
10. 防护等级: IP00-IP22

典型电路图
(Typical circuit diagram)

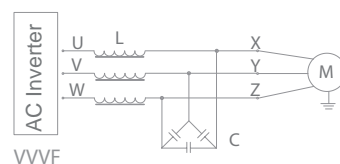

11. 最大电流: 1.5 \times 额定电流,持续60S
12. 噪音: \leq 65dB
13. 温升: \leq 85K
14. 抗电强度: 铁芯-绕组 3000VAC/50Hz/5mA/10s无飞弧击穿(工厂测试)
15. 绝缘电阻: 1000VDC绝缘阻值 \geq 100M Ω
16. 海拔高度不超过2000米。
17. 运行环境温度-25 $^{\circ}$ C \sim +45 $^{\circ}$ C,相对湿度不超过90%。
18. 周围无有害气体,无易燃易爆物品。
19. 周围环境应有良好的通风条件,如装在柜内,应加装通风设备。

1. Work Voltage: 220VAC-690VAC
2. Work Current: 15A-1500A
3. Work Frequency: 50/60Hz
4. Switching frequency: 2~8KHz
5. Insulation Class: class F, H
6. Rated voltage drop: 8~12%
7. Voltage harmonic distortion: THD \leq 5%
8. Load Current \leq 8%
9. Operation Environment:-10 \sim +45 $^{\circ}$ C, rated value won't lower, when higher than 55 $^{\circ}$ C, and every 1 $^{\circ}$ C, the current will step down 2%
10. Protection class: IP00-IP22
11. Max Current: 1.5 \times Rated current, continuous 60S
12. Noise: \leq 65dB
13. Temperature Rise: \leq 85K
14. Dielectric strength: Core Coil 3000VAC/50Hz/5mA/10s no electric arcing puncture (factory test)
15. Insulation Resistor: 1000VDC insulation resistance value \geq 100M Ω
16. Under seal level 2000m
17. Running ambient temperature -25 $^{\circ}$ C \sim +45 $^{\circ}$ C, comparative moisture not over 90%.
18. No hazardous gas, no inflammables and explosives
19. With well-ventilated condition, ventilation devices shall be mounted if installation in panels

■ 执行标准 (Applicable Standards)

IEC289: 1987 Reactor
GB10229-88 Reactor (equiv IEC289: 1987)
JB9644-1999 Reactors used for semiconductor electrical driving

Sine Wave Filter Current Derating for Drive Output Frequency

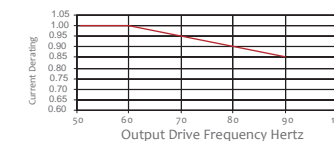

Altitude Derating Curve

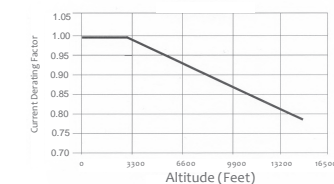

Raw output voltage waveform

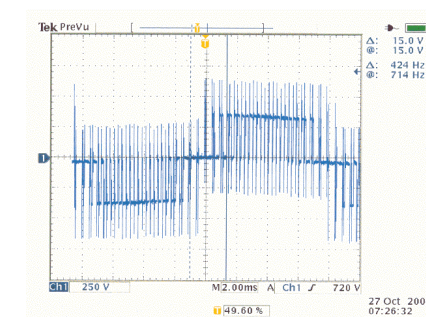

Output Voltage after Sine Wave Filter

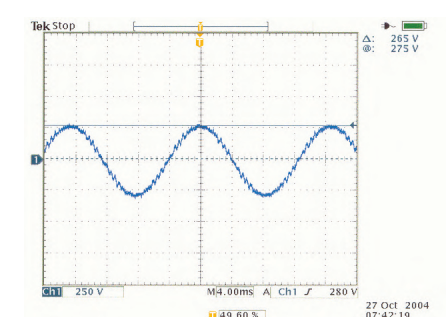

■ 成品识别码 (Product Identification Code)

SFR	0330	0M20	0.45C
正弦波滤波器 Sine Wave Filter	额定电流 Rated Current	电感量 Inductance	0.4: Working Voltage 0.2=220V, 0.4=380V, 0.7=690V, 1.1=1140V S: D=Single Phase Reactor S=Three Phase Reactor C: C=Copper A: Aluminium

■ 产品尺寸图 (Product Size)

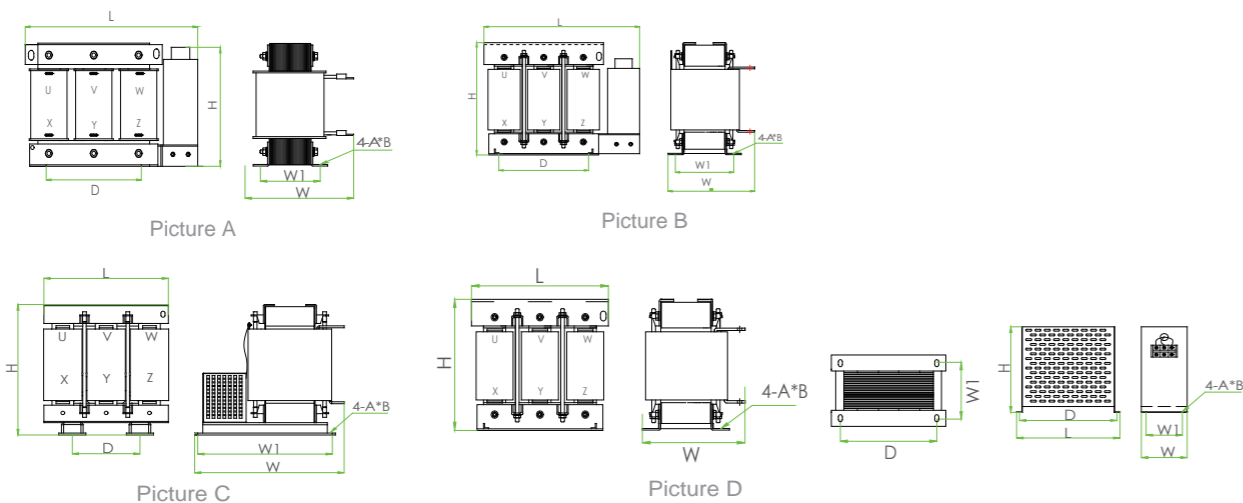

滤波器型号 TYPE	适配功率 Power(kw)	图号 Picture NO.	额定电流 Rated Current (A)	绝缘等级 Insulation Class	尺寸 Dimension(±5mm)						
					L(max)	W(max)	H(max)	W1±2	D±2	A*B	
SFR-0007-8M00-0.4SC	2.2	图 A Picture A	7	F,H	195	200	195	72	120	8.5*20	
SFR-0010-6M00-0.4SC	3.7		10	F,H	275	160	265	92	120	8.5*20	
SFR-0015-4M00-0.4SC	5.5		15	F,H	275	160	265	92	120	8.5*20	
SFR-0020-3M00-0.4SC	7.5		20	F,H	290	160	250	110	120	11*18	
SFR-0030-2M00-0.4SC	11		30	F,H	330	185	250	104	182	11*18	
SFR-0040-1M50-0.4SC	15		40	F,H	330	185	250	104	182	11*18	
SFR-0050-1M20-0.4SC	18.5	图 B Picture B	50	F,H	380	210	260	118	214	11*18	
SFR-0060-1M10-0.4SC	22		60	F,H	380	210	260	118	214	11*18	
SFR-0080-0M85-0.4SA	30		80	F,H	460	230	290	149	243	11*18	
SFR-0090-0M80-0.4SA	37		90	F,H	460	230	290	149	243	11*18	
SFR-0120-0M52-0.4SA	45		120	F,H	525	270	335	164	260	15*25	
SFR-0150-0M45-0.4SA	55		150	F,H	525	270	350	174	260	15*25	
SFR-0200-0M30-0.4SA	75	图 C Picture C	200	F,H	525	310	350	194	260	15*25	
SFR-0250-0M28-0.4SA	110		250	F,H	550	335	375	214	260	15*25	
SFR-0290-0M23-0.4SA	132		290	F,H	540	330	430	216	260	15*25	
SFR-0330-0M20-0.4SA	160		330	F,H	600	340	450	204	350	15*25	
SFR-0390-0M17-0.4SA	185		390	F,H	600	340	460	216	350	15*25	
SFR-0490-0M14-0.4SA	220		490	F,H	480	580	560	480	300	15*25	
SFR-0600-0M12-0.4SA	280	图 D Picture D	600	F,H	480	640	575	510	300	15*25	
SFR-0660-0M10-0.4SA	315		660	F,H	480	640	575	510	300	15*25	
SFR-0800-087U-0.4SA	380		800	F,H	550	400	640	320	360	15*25	
电容+壳体 Capacitor+ Shell						520	165	310	100	480	11*18
SFR-1000-070U-0.4SA	450		1000	F,H	680	490	750	320	400	15*25	
电容+壳体 Capacitor+ Shell						565	180	380	100	540	11*18
SFR-1200-058U-0.4SA	500	图 D Picture D	1200	F,H	680	510	780	320	400	15*25	
电容+壳体 Capacitor+ Shell						410	360	380	275	380	11*18
SFR-1500-050U-0.4SA	630		1500	F,H	700	530	800	370	400	15*25	
电容+壳体					565	365	380	275	540	11*18	

备注：其他规格尺寸，可根据用户要求制造。Remark: Dimension can be customization

LCL滤波器 (LCL Filters)

■ 产品概述 (Product Introduction)

LCL 滤波器在现代的可再生能源行业十分普遍，可以有效、经济地确保和提高从能源到电网的馈电质量。滤波器用于过滤逆变器的开关频率。达到目标畸变水平时，滤波器将节约可观的成本。LCL 滤波器的典型特点是损失小、体积小、重量轻、电容大

LCL filters are very commonly used in the modern renewable energy industry, and can efficiently and economically ensure and improve the feed quality from energy sources to the grid. The filters are used for filtration of the switching frequency of the inverter. When reaching the target distortion level, the filters can save considerable costs. LCL filters are typically characterized by small loss, small size, light weight, and high capacitance.

■ 产品特点 (Product Features)

功率半导体开关器件技术的进步，促进了电力电子变流装置技术的迅速发展，出现了以脉宽调制(PWM)控制为基础的各类变流装置，比如逆变电源，变频器等各类变流器，并且这些变流器已经在全国的各个领域中得到了广泛的应用。三相电压型PWM整流器具有电能双向传输，较快的动态控制响应。当前的PWM整流器采用的功率开关器件多是IGBT，就可以实现很高的开关频率，一般开关频率为2kHz~15kHz。然而功率开关器件的高开通关断频率却会产生高次谐波，注入到电网中，产生谐波污染。为了解决LCL滤波器所碰到的难题，我们一般选择LCL滤波器。LCL滤波器可以选取较小的电感电容值，在千瓦至上百千瓦间实现满意的滤波效果。

The advancement of the technology of the high power semiconductor switching device promotes the rapid development of the technology of power electronic converters, giving birth to various types of converters, such as inverter power supplies, frequency converters, etc. And these converters have been widely used in various fields all over the country. Three-phase voltage-type PWM rectifiers have the functions of bidirectional power transmission and fast dynamic control response. Most PWM rectifiers currently adopt IGBT as the power switch device, which can achieve very high switching frequency compared to the general switching frequency of 2kHz-15kHz. However, the high on/off frequency of power switch device will generate high order harmonics to be injected into the grid, thus causing harmonic pollution. In order to solve the problems encountered by LCL filters, we generally choose LCL filters. Smaller inductance and capacitance values can be selected for the LCL filters to achieve satisfactory filtering effects between one kilowatt to hundreds of kilowatts.

电流范围 Current Range: 10-1600A
电压范围 Voltage Range: 220-1140V

■ 成品识别码 (Product Identification Code)

LCL - 250 - 0.4SC

LCL滤波器 LCL Filter 额定电流 Rated Current 0.4: Working Voltage
0.2=220V, 0.4=380V, 0.7=690V, 1.1=1140V
S: D=Single Phase Reactor
S=Three Phase Reactor
C: C=Copper
A: Aluminium

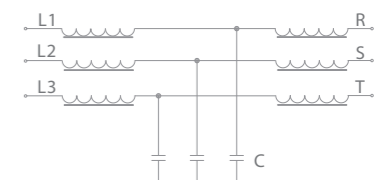
典型电路图
(Typical circuit diagram)

中频正弦波滤波器

High frequency SineWave Filter

■ 产品概述 (Product Introduction)

正弦波滤波器是在PWM变频器驱动下，其开关频率范围在2 - 8kHz之间仍提供正弦波输出电压。在变频器驱动应用中，这种滤波器可以消除电机绝缘失效问题并通过消除与变频器输出波形相关的高dV/dT来减少电磁干扰，改善电机的性能和寿命，延长变频器输出距离，最长可达3KM。

A sine wave filter, driven by a PWM frequency converter, provides a sine wave output voltage within a switching frequency range of 2-8kHz. In the application of frequency converter drive, this filter can eliminate the problem of motor insulation failure and reduce electromagnetic interference by eliminating high dV/dT related to the output waveform of the frequency converter, improving the performance and life of the motor, and extending the output distance of the frequency converter, up to 3km.

为保护电线电缆，使用正弦波滤波器可防止长引线驱动电机的过电压问题。在其他能源应用下，比如风力发电机，逆变器将电力通过升压变压器还原到实用的配电系统。这种滤波器可以允许使用标准变压器。满载并在60Hz时给变压器输入的谐波电压畸变最大值是5%的话，那么满载时给电机输入的谐波电压畸变一般就是5%。

To protect wires and cables, using a sine wave filter can prevent overvoltage problems in long lead driven motors. In other energy applications, such as wind turbines, inverters restore electricity to practical distribution systems through step-up transformers, which can allow the use of standard transformers. If the maximum harmonic voltage distortion input to the transformer at full load and 60Hz is 5%, then the harmonic voltage distortion input to the motor at full load is generally 5%.



典型电路图

(Typical circuit diagram)

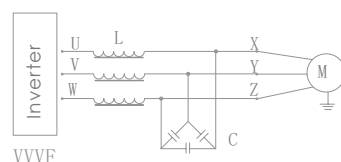

■ 产品尺寸图 (Product Size)

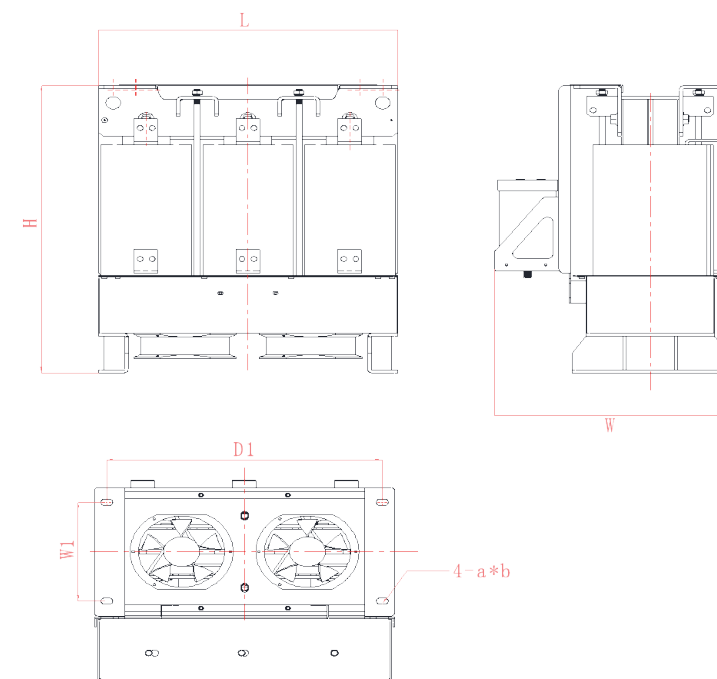

滤波器型号 TYPE	材质 Material	适配功率 Power (kw)	额定输出 电流 Rated out put current	参考电机 频率 Reference mo tor frequency	绝缘 等级 Insulation Class	载波 频率 carrier fre quency	电感 Inductance	尺寸 Dimension(±5mm)					重量 weight	
								L(max)	H(max)	W(max)	W1±1	D1±2		A*B
IFSFR-0075-0M26-0.4SA		37	75		F、H		0.26	320	430	330	150	300	13*20	40
IFSFR-0092-0M22-0.4SA		45	92		F、H		0.22	320	430	330	150	300	13*20	45
IFSFR-0115-0M17-0.4SA		55	115		F、H		0.17	350	450	350	160	310	13*20	50
IFSFR-0150-0M13-0.4SA		75	150		F、H		0.13	400	500	380	180	345	13*20	62
IFSFR-0180-0M11-0.4SA		90	180		F、H		0.11	400	500	380	180	345	13*20	70
IFSFR-0215-0M11-0.4SA		110	215	400-500	F、H		0.11	400	550	380	200	345	13*20	90
IFSFR-0260-0M11-0.4SA		132	260		F、H		0.11	400	550	380	200	345	13*20	100
IFSFR-0305-0M11-0.4SA		160	305		F、H		0.11	500	610	435	200	460	13*20	125
IFSFR-0340-070U-0.4SA		185	340		F、H		0.07	500	590	435	200	460	13*20	120
IFSFR-0380-070U-0.4SA	AL	200	380		F、H	≤6K	0.07	500	680	435	200	460	13*20	140
IFSFR-0425-045U-0.4SA		220	425		F、H		0.045	500	630	435	200	460	13*20	130
IFSFR-0480-045U-0.4SA		250	480		F、H		0.045	500	685	435	200	460	13*20	140
IFSFR-0530-050U-0.4SA		280	530		F、H		0.05	500	720	465	220	460	13*20	165
IFSFR-0600-045U-0.4SA		315	600	300-500	F、H		0.045	500	780	465	220	460	13*20	190
IFSFR-0650-030U-0.4SA		355	650		F、H		0.03	500	700	500	200	460	13*20	150
IFSFR-0720-025U-0.4SA		400	720		F、H		0.025	500	780	500	200	460	13*20	165
IFSFR-0820-022U-0.4SA		450	820	400-600	F、H		0.022	500	800	500	200	460	13*20	195
IFSFR-0860-022U-0.4SA		500	860		F、H		0.022	500	800	500	200	460	13*20	205

备注：其他规格尺寸，可根据用户要求制造。Remark: Dimension can be customization

能量回馈电抗器 (EFR) Energy Regenerated Reactor

产品概述 (Product Introduction)

变频器制动时所产生的再生能量回馈到电网，并加以利用，但是整流单元是IGBT，会产生较多的高次谐波电流，进而会对电网污染。所以在变频器的前端加上能量回馈电抗器和滤波器组合以改善电能质量。The regenerative energy generated during the braking of the frequency converter is fed back to the power grid and utilized, but the rectifier unit is an IGBT, which generates a large amount of high-order harmonic current and can pollute the power grid. So adding an energy feedback reactor and filter combination at the front end of the frequency converter to improve power quality.

电流范围 Current Range: 10-1000A
电压范围 Voltage Range: 220-1140V



成品识别码 (Product Identification Code)

EFR	0080	0M54	0.4SC
能量回馈电抗器 Energy Regenerated Reactor	额定电流 Rated Current 30A-1600A	电感量 Resistance Value M:mH U:uH	0.4:Working Voltage 0.2=220V,0.4=380V,0.7=690V,1.1=1140V S: D=Single Phase Reactor S=Three Phase Reactor C: C=Copper A:Aluminium

矿用防爆电抗器 (BFR) Mine Explosion Reactor

产品概述 (Product Introduction)

矿用防爆变频器为封闭金属外壳，变频器及其外围器件都安装在封闭的空间内，由于结构的特殊性，变频器的主要发热器件即功率模块IGBT采用真空热管或者水冷散热方式，但是电抗器等器件也是系统内较大的发热源，像一个电炉在持续发热，如何减小电抗器的发热量，关系到变频器的运行可靠性及机器寿命。我们通过磁芯和导体发热的合理选择，处理以及反复验算，保证了电抗器在密闭条件下的高性能运行。

Mine explosion-proof inverter has a closed metal housing, and the inverter and peripheral devices are installed in a closed space. Because of the special structure, the main heating device of the inverter, i.e., the power module IGBT, uses vacuum heat pipe cooling or water cooling method. However, the reactors and other devices are also large heat source within the system, just like a continuously heating furnace. The method to reduce the reactor's heat is related to the operational reliability of the inverter and the life of the machine. Through processing and repeated checking based on a reasonable choice of magnetic core and conductor heating, ensuring the high-performance operation in confined conditions.

电流范围 Current Range: 10-1000A
电压范围 Voltage Range: 220-1140V

成品识别码 (Product Identification Code)

BFR	0080	0M54	0.4SC
防爆四象限电抗器 Explosion four quadrant reactor	额定电流 Rated Current 30A-1600A	电感量 Resistance Value M:mH U:uH	0.4:Working Voltage 0.2=220V,0.4=380V,0.7=690V,1.1=1140V S: D=Single Phase Reactor S=Three Phase Reactor C: C=Copper A:Aluminium

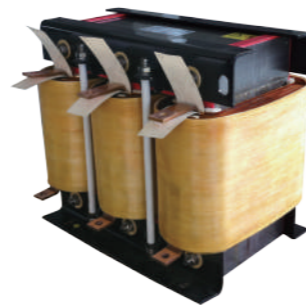

空心电抗器 (HAR) Core Reactor

产品概述 (Product Introduction)

采用高品质的环氧树脂真空浸渍，并高温固化。该产品具有节能、电感线性度好，电抗值精确、线圈温升分布均匀、动热稳定性高，抗短路、过载能力强，绝缘强度高，电磁场均匀性好，损耗低，温升低使用寿命长，基本免维护，噪声低，阻燃、无污染体积小、重量轻和安装运用使用方便等特点。

It applies the high quality epoxy resin vacuum impregnation, solidification through high temperature. The product has the features of energy saving, good inductive performance, accurate resistance value, uniform distribution of coil temperature rise, high dynamic thermal stability, anti-short circuit, strong overload ability, good insulation intensity, good uniform distribution of electromagnetic field, low loss, low temperature rise, long service life, maintenance-free, low noise, flame-retardant, pollution-free, small size, light weight, and easy to installation and use and so on.

产品应用 (Product Application)

一般用于配电线路。从同一母线引出的分支馈线上往往串有空心限流电抗器，以限制馈线的短路电流并维持母线电压，不致因馈线短路而致过低。并在其表面进行耐候涂层处理：喷涂具有高绝缘电阻和憎水性的室温硫化硅橡胶(RTV),利用RTV胶的优良绝缘性能，使电抗器沿面电阻保持较好的绝缘性能，对电抗器产品表面树枝状放电现象具有很好的抑制作用。从而保证空心限流电抗器在户外环境下安全运行。该产品应用计算机进行电磁优化计算和空间三维结构设计，采用环氧玻纤增强的多包封并联结构、使用先进的工艺技术和微机控制的生产设备及引进的检验设备进行生产和检验。该产品具有电感线性好、损耗低、温度分布均匀、绝缘强度高、机械强度高、局放小、噪音低、体积小、重量轻、防潮、阻燃、过载能力强、可靠性高、无污染、免维护、环境效果好等优点。

Generally used for distribution lines. Hollow current limiting reactors are often connected in series on branch feeders from the same busbar to limit the short-circuit current of the feeder and maintain the busbar voltage, so as not to be too low due to feeder short circuits. And weather resistant coating treatment is applied to its surface: spraying room temperature vulcanized silicone rubber (RTV) with high insulation resistance and hydrophobicity, utilizing the excellent insulation performance of RTV rubber to maintain good insulation performance along the surface resistance of the reactor, and effectively suppressing the dendritic discharge phenomenon on the surface of the reactor product. Thus ensuring the safe operation of hollow current limiting reactors in outdoor environments. This product uses computers for electromagnetic optimization calculations and spatial 3D structure design. It adopts a multi encapsulated parallel structure reinforced with epoxy fiberglass, advanced process technology, microcomputer controlled production equipment, and imported inspection equipment for production and inspection. This product has the advantages of good inductance linearity, low loss, uniform temperature distribution, good insulation strength, high mechanical strength, small partial discharge, low throat sound, small size, light weight, moisture-proof, flame retardant, strong overload capacity, high reliability, pollution-free, maintenance free, and good environmental effect.

电流范围 Current Range: 30-1600A
电压范围 Voltage Range: 220-35KV

成品识别码 (Product Identification Code)

HAR	0080	0M54	0.4SC
空心电抗器 Core reactor	额定电流 Rated Current 30A-1600A	电感量 Resistance Value M:mH U:uH	0.4:Working Voltage 0.2=220V,0.4=380V,0.7=690V,1.1=1140V S: D=Single Phase Reactor S=Three Phase Reactor C: C=Copper A:Aluminium



变频器尖峰电压吸收器 (HVT-A4)

Inverter peak voltage absorber

产品概述 (Product Introduction)

变频器驱动电机的电压是脉冲波形(PWM波形),这种波形包含了丰富的高频成份。当变频器与电机之间的连线超过30米时,高频驱动电压脉冲会对电机产生很多不良影响,其中主要包括:电机轴承寿命缩短,电机定子绕组绝缘击穿等。例如,对于额定电压380V的变频器,脉冲电压的尖峰幅度可超过1200V,这种尖峰电压每秒对电机冲击上千次,很快就导致电机定子绕组的损坏。此外,变频器的输出脉冲电压还会在电机的轴承中产生轴承电流,轴承中长时间流过轴承电流,会造成电机轴承的损坏。

The voltage of the motor driven by the frequency converter is a pulse waveform (PWM waveform), which contains rich high-frequency components. When the connection between the frequency converter and the motor exceeds 30 meters, high-frequency driving voltage pulses can have many adverse effects on the motor, including shortened bearing life and insulation breakdown of the motor stator winding. For example, for a frequency converter with a rated voltage of 380V, the peak amplitude of the pulse voltage can exceed 1200V. This peak voltage can impact the motor thousands of times per second, quickly causing damage to the motor stator winding. In addition, the output pulse voltage of the frequency converter will also generate bearing current in the bearings of the motor. If the bearing current flows through the bearings for a long time, it will cause damage to the motor bearings.



产品应用 (Product Application)

HVT尖峰电压吸收器是保护电机定子绕组绝缘和轴承的创新性产品。HVT并联安装在电机的电源输入端能够有效吸收变频器在电机上产生的尖峰电压和轴承电流,极大地延长电机的寿命。

HVT spike voltage absorber is an innovative product that protects the insulation of motor stator windings and bearings. HVT is installed in parallel at the power input end of the motor, which can effectively absorb the peak voltage and bearing current generated by the frequency converter on the motor, greatly

与传统的du/dt滤波器或正弦波滤波器相比, HVT优点有

- 1.与电动机并联安装, 简便易行;
- 2.没有电压降, 不降低力矩, 也不影响变频器对电机的控制;
- 3.体积小、重量轻, 性价比高, 特别是对于大功率电机, 优势更加明显;
- 4.选用方便, 与电机的转速和载波频率无关, 不用与特定功率的电机配型;
- 5.智能控制, 根据载波频率和电缆长度, 自动调节吸收功率, 确保效果最佳;
- 6.内置保险, 故障时自动从系统中脱出, 同时, 面板上显示故障状态;
- 7.全密封设计, 适应恶劣的工业现场环境。

Compared with traditional du/dt filters or sine wave filters, HVT has the advantages of

1. Parallel installation with electric motor, simple and easy to implement;
2. No voltage drop, no reduction in torque, and no impact on the control of the motor by the frequency converter;
3. Small size, light weight, high cost-effectiveness, especially for high-power motors, the advantages are more obvious;
4. Convenient selection, independent of motor speed and carrier frequency, without the need to match with specific power motors;
5. Intelligent control, automatically adjusts the absorbed power according to the carrier frequency and cable length to ensure optimal performance;
6. Built in insurance, automatically disengages from the system in case of malfunction, and displays the fault status on the panel;
7. Fully sealed design, suitable for harsh industrial site environments.

产品特点 (Product Features)

- 1.解决变频器烧毁电机定子绕组;
 - 2.实时检测尖峰电压, 快速吸收尖峰
 - 3.智能控制能量吸收阀门, 发挥最大吸收能力,
 - 4.IGBT技术控制尖峰电压能量吸收, 尖峰电压吸收干净彻底;
 - 5.轴承电流吸收电路, 大大延长轴承寿命;
 - 6.智能控制模块工作不用外接电源;
 - 7.工作状态面板显示, 随时了解工作状态;
 - 8.与电机并联安装, 接线简单。
1. Solve the problem of frequency converter burning out the motor stator winding;
 2. Real time detection of peak voltage and rapid absorption of peaks
 3. Intelligent control of energy absorption valves to maximize absorption capacity,
 4. IGBT technology controls the absorption of peak voltage energy, ensuring clean and thorough absorption of peak
 5. The bearing current absorption circuit greatly extends
 6. The intelligent control module does not require an external power supply to operate;
 7. Display the work status panel to keep track of the work status at any time;
 8. Parallel installation with motor, simple wiring.

典型电路图

(Typical circuit diagram)

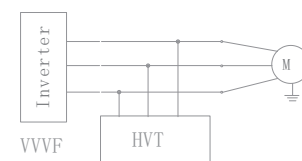

变频器对定子绕组的损伤

The damage of inverter to stator winding

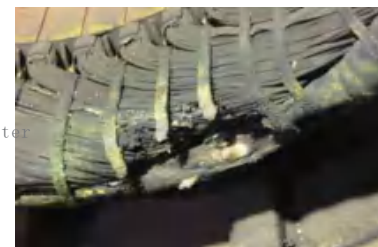

变频器对电机轴承的损伤

Frequency converter to motor bearing damage



没有安装HVT时, 电机端的过冲电压超过1200V, (150米电缆)

When no HVT is installed, the motor-end overshoot voltage

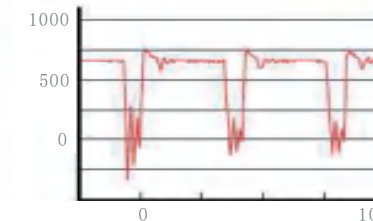
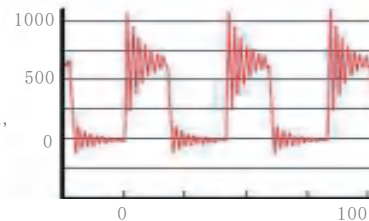

安装HVT后, 电机端的过冲电压低于800V, (150米电缆)

After the installation of HVT, the motor end overshoot, voltage below 800V, (150 m cable)

技术规格 (Technical Specifications)

1. 尖峰电压吸收原理: 实时检测尖峰电压, 将电能转变成热能, 耗散到空间
Principle of Peak Voltage Absorption: Real time detection of peak voltage, converting electrical energy into thermal energy, and dissipating it into space
 2. 轴承电流吸收方式: 高频共模电流旁路网络
Bearing current absorption method: high-frequency common mode current bypass network
 3. 额定电压: 变频器的额定工作电压为400Vac、690Vac
Rated voltage: The rated operating voltage of the frequency converter is 400Vac and 690Vac
 4. 变频器载波频率 Carrier frequency of frequency converter: < 12KHz
 5. 变频器最大功率 Maximum power of inverter: 1500KW
 6. 允许电机电缆长度 Allowable motor cable length: 300 m
 7. 工作时壳体温度: 小于90℃, 环境温度为50℃
Shell temperature during operation: less than 90 °C, ambient temperature is 50 °C
 8. 绝缘电阻 Insulation resistance: > 100MΩ
 9. 耐压: 导电部分与外壳承受2000VAC, 时间1min, 无击穿和闪络现象
Voltage resistance: The conductive part and the shell can withstand 2000VAC for 1 minute without breakdown or flashover
 10. 工作环境: -10℃至+50℃, 最高海拔3000米, 相对湿度95%
Working environment: -10 °C to +50 °C, maximum altitude of 3000 meters, relative humidity of 95%
- 备注: 如有超出上述参数, 请于我公司联系。
Note: If you exceed the above parameters, please contact our company.

产品尺寸图 (Product Size)

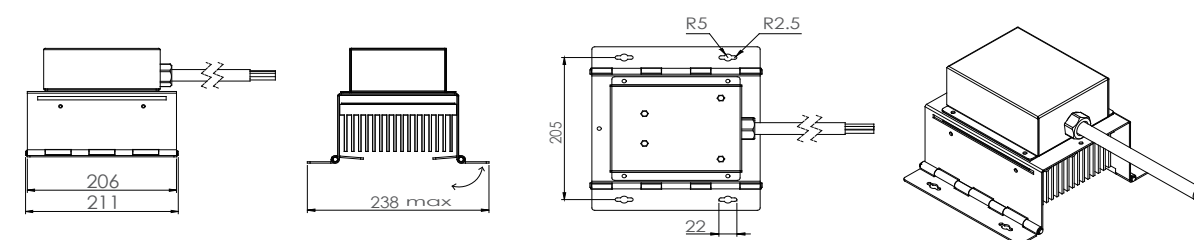

成品识别码 (Product Identification Code)

HVT	-	A	-	4
变频器尖峰电压吸收器 Inverter peak voltage absorber		电机功率 Motor Power A: <30KW B: 30-100KW C: 100-250KW D: >250KW		工作电压 Operating voltage 4: 400V 7: 690V

调谐电抗器 (ATR) Tuning Reactor

产品概述 (Product Introduction)

现代电力电子设备的大量使用产生的非线性电流正以谐波方式影响电网并加重电网污染，并导致电容器、变压器及传输设备过载并故障，对测量，传动，计算等设备产生的严重干扰，谐振及电压畸变还造成供电事故。串联电抗器可得以改善与避免。电容器串联电抗器后谐振频率低于系统最低（一般为5次及7次），使其在工频下呈容性，以改善功率因数，而在谐振并无放大谐波之滤，良好的阻抗匹配后，电容器组可吸收谐波电流(如5次)30%-60%。

The nonlinear currents generated by the massive use of modern power and electric equipment are impacting the power grid and aggravate its pollution in the harmonic form, cause overload failures to capacitors, transformers and transmission devices and generate serious interference to measuring, transmitting and calculating devices; in addition, resonance and voltage distortions may also result in power supply accidents, Series reactors could effectively improve or avoid such problems. After installing the capacitor and reactor in series, the resonance frequency is lower than the minimum of the system (usually 5th and 7th waves), so that compatibility is showed under power frequency and power factor is improved; meanwhile, there is no need to worry about the amplification of harmonic wave. With satisfactory impedance matching, the capacitor bank could absorb 30% to 60% of the harmonic currents (5th harmonic wave, for example).

技术规格 (Technical Specifications)

基波电流 Fundamental Current	$I_1 = 1.06 * I_R$ (I_R 为电容器额定电流 I_R is capacitor rated current) $U_3 = 0.5\% U_R$ (基波电压为100% The fundamental voltage is 100%) $U_5 = 6.0\% U_R$		
谐波电压 Harmonic voltage	$U_7 = 5.0\% U_R$ $U_{11} = 3.5\% U_R$ $U_{13} = 3.0\% U_R$		
有效电流 Effective current	$I_{RMS} = \sqrt{I_1^2 + I_3^2 + \dots + I_{13}^2}$		
线性度 Linearity	$2.08 * I_1$ $P = 5.67\%$	$1.73 * I_1$ $P = 7\%$	$1.4 * I_1$ $P = 14\%$
温度保护 Temperature protection	微型开关 (常闭) Miniature switch (normally closed)		
频率 Frequency	50Hz/60Hz		
电压等级 Voltage level	400V, 440V, 480V, 525V, 690V		
输出容量 Output capacity	5-100Kvar		
电抗率 Reactance	5.67%, 7%, 14%		

功能特点 (Functional characteristics)

采用多段气隙 Adopt multi-section air gap	分隔芯柱 Separate core column	温度保护 Temperature protection
采用真空浸漆 Use vacuum dip paint	低噪音 Low noise	F/H级 Grade F/H
高线性度 High linearity	低损耗 Low loss	耐高温绝缘 High temperature resistant insulation

芯柱与绕组之间设置通风道散热

A ventilation channel is arranged between the core column and the winding for heat dissipation

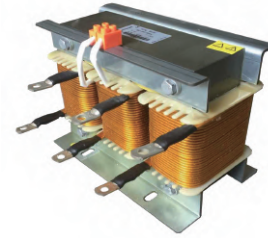

典型电路图

(Typical circuit diagram)

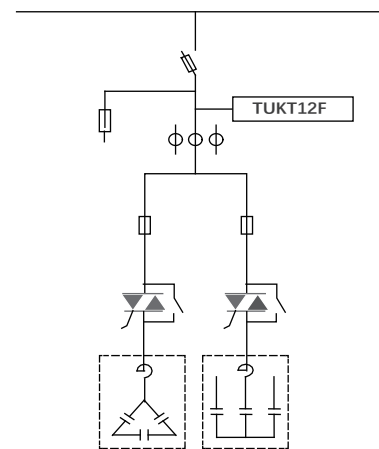

调谐电抗器选型表 (Type list of tuning reactor)

三相共补 Three-phase complement 400V, 50Hz, P=7%, fr=189Hz for 480V Capacitor

规格型号 TYPE	额定容量 Nameplate capacity (Kvar)	额定电流 Rated current (A)	额定电感 Rated inductance (mH)	外形尺寸 External dimensions (mm)						
				A	B	C	D	E	F	G
ATR-0025-2M58-0.4SAL	20	24.4	2.568	235	160	160	150	93	7*14	7.5
ATR-0031-2M05-0.4SAL	25	30.5	2.054	235	160	160	150	93	7*14	7.5
ATR-0037-1M73-0.4SAL	30	36.6	1.712	235	150	160	150	93	7*14	7.5
ATR-0050-1M29-0.4SAL	40	48.8	1.285	255	185	215	150	125	9*17	10.5
ATR-0061-1M03-0.4SAL	50	61.0	1.028	255	185	215	150	125	9*17	10.5
ATR-0074-0M86-0.4SAL	60	73.3	0.856	250	185	215	150	125	9*17	10.5

三相共补 Three-phase complement 400V, 50Hz, P=14%, fr=134Hz for 525V Capacitor

规格型号 TYPE	额定容量 Nameplate capacity (Kvar)	额定电流 Rated current (A)	额定电感 Rated inductance (mH)	外形尺寸 External dimensions (mm)						
				A	B	C	D	E	F	G
ATR-0028-4M92-0.4SAL	25	27.5	4.916	255	185	215	150	125	9*17	10.5
ATR-0042-3M28-0.4SAL	37	41.2	3.279	285	190	215	175	125	9*17	10.5
ATR-0055-2M46-0.4SAL	50	55.0	2.457	300	190	215	175	125	9*17	10.5
ATR-0083-1M64-0.4SAL	75	82.4	1.640	335	190	255	175	150	11*18	12.5

备注：其他规格尺寸，可根据用户要求制造。Remark: Dimension can be customization

调谐电抗器外形尺寸 (External dimension of tuning reactor)

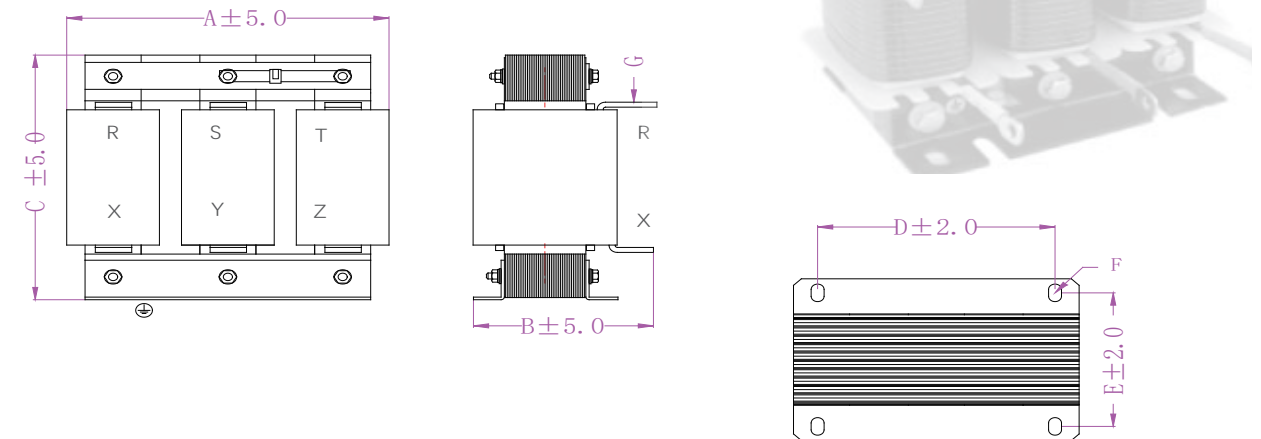

成品识别码 (Product Identification Code)

ATR	—	0037	—	1M73	—	0.4SAL
调谐电抗器 Tuning Reactor		额定电流 Rated Current		电感量 Inductance		0.4: Working Voltage 0.2=220V, 0.4=380V, 0.7=690V, 1.1=1140V S: Single Phase Reactor S=Three Phase Reactor C: Copper A: Aluminium

中压电抗器 Medium voltage reactor

■ 产品概述 (Product Introduction)

干式铁芯串联电抗器是电力系统无功补偿装置的重要配套设备。电力电容器与干式铁芯电抗器串联后，能有效地抑制电网中的高次谐波，限制合闸涌流及操作过电压，改善系统的电压波形，提高电网功率因数，对电力电容器及其它电力设备的安全运行起到了较大的作用。

Dry type iron core series reactor is an important supporting equipment of reactive power compensation device in power system. After the power capacitor and dry-type iron core reactor are connected in series, it can effectively restrain the high-order harmonics in the power grid, limit the switching inrush current and switching overvoltage, improve the voltage waveform of the system, and improve the power factor of the power grid, which plays a great role in the safe operation of power capacitors and other power equipment.



■ 技术规格 (Technical Specifications)

额定电压
Rated voltage 3kV、6kV、10kV，高压型号可达66kV
Common are 3kV, 6kV, 10kV, and the high-voltage model can reach 66kV

额定电流
Rated current 50A，具体根据容量调整
50A, Specific adjustment according to capacity

阻抗电压
Impedance voltage 需符合GB1094、GB10229国家标准
it shall comply with GB1094 and gb10229 national standards

过载能力
Overload capacity 1.35倍额定电流下可连续运行
continuous operation under 1.35 times of rated current

电抗率
Reactance rate 1%、2%、6%、7%、14%

串联电抗器在谐波次数与电抗率配套使用时，谐波电流标准值大约在：20%左右。如谐波电流超标或偏大(如：中频……等负载时)需按非标定制。

When the series reactor is used together with the harmonic number and reactance rate, the standard value of harmonic current is about 20%. If the harmonic current exceeds the standard or is too large (for example, if the load is medium frequency...), it needs to be customized according to non-standard.

根据串联电抗器的应用性能定制(如有特殊要求应事先声明)
Customized according to the application performance of series reactor (if there are special requirements, it shall be declared in advance)

海拔不超过 1000m The altitude shall not exceed 1000m.

环境温度-25~+45C，相对湿度不超过90%
The ambient temperature is -25~+45c, and the relative humidity is not more than 90%.

电源电压的波形近似于正弦波 The waveform of power supply voltage is similar to sine wave.

周围无有害气体，无易燃易爆物品
The waveform of power supply voltage is similar to sine wave.

周围环境应有良好的通风条件，如装在柜内，应加装通风设备
The surrounding environment should have good ventilation conditions. If installed in the cabinet, ventilation equipment should be installed.

■ 执行标准

Applicable Standards

- 1.DL462-92 《高压并联电容器用串联电抗器订货技术条件》
- 2.IEC289-88 《电抗器》 3.GB10229-88 《电抗器》
- 4.JB5346-98 《电抗器》

■ 产品尺寸图 (Product Size)

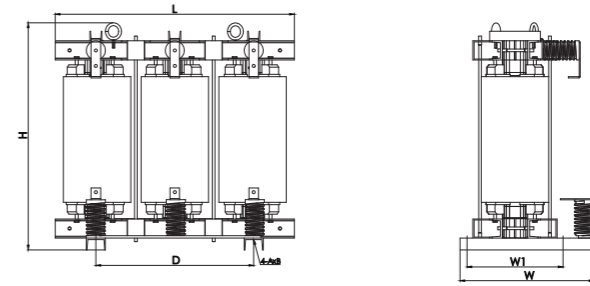

系统电压6KV，串6%电抗器参数表

规格型号	电抗率	容量 (kVar)	6KVAC时		外形尺寸 (mm)					
			输出容量(Kvar)	最大电流(A)	A	B	H	C	F	安装孔
GR6- 7.2KV- 1 00S AX	6%	100	74	8.03	655.00	320.00	630.00	410.00	220.00	φ14
GR6- 7.2KV- 150S AX	6%	150	110.8	12.03	700.00	330.00	680.00	440.00	240.00	φ14
GR6- 7.2KV- 200S AX	6%	200	147.8	16.05	700.00	330.00	680.00	440.00	240.00	φ14
GR6- 7.2KV- 300S AX	6%	300	221.6	24.06	760.00	350.00	730.00	480.00	240.00	φ14
GR6- 7.2KV- 4 00S AX	6%	400	295.7	32.09	790.00	360.00	820.00	500.00	260.00	φ14
GR6- 7.2KV- 450S AX	6%	450	332.1	36.08	790.00	360.00	820.00	500.00	260.00	φ14
GR6- 7.2KV- 500S AX	6%	500	369.5	40.10	820.00	380.00	870.00	520.00	260.00	φ14
GR6- 7.2KV- 600S AX	6%	600	443.3	48.11	820.00	380.00	870.00	520.00	280.00	φ14
GR6- 7.2KV- 750S AX	6%	750	554.1	60.14	820.00	380.00	880.00	520.00	280.00	φ14
GR6- 7.2KV- 900S AX	6%	900	664.9	72.17	880.00	380.00	930.00	560.00	280.00	φ14
GR6- 7.2KV- 1000S AX	6%	1000	738.6	80.35	880.00	400.00	950.00	560.00	300.00	φ14
GR6- 7.2KV- 1200S AX	6%	1200	886.5	96.23	910.00	400.00	955.00	580.00	300.00	φ14
GR6- 7.2KV- 1500S AX	6%	1500	1108.2	120.28	1015.00	420.00	1060.00	650.00	300.00	φ14
GR6- 7.2KV- 1800S AX	6%	1800	1329.8	144.34	1045.00	440.00	1080.00	670.00	300.00	φ14
GR6- 7.2KV- 2400S AX	6%	2400	1773	192.45	1090.00	490.00	1180.00	700.00	350.00	φ14

系统电压10KV，串6%电抗器参数表

规格型号	电抗率	容量 (kVar)	6KVAC时		外形尺寸 (mm)					
			输出容量(Kvar)	最大电流(A)	A	B	H	C	F	安装孔
GR6- 12KV- 100S AX	6%	100	74	4.82	715	320	680	450	220	φ14
GR6- 12KV- 150S AX	6%	150	110.8	7.22	745	330	680	470	240	φ14
GR6- 12KV- 200S AX	6%	200	147.8	9.63	775	340	740	490	250	φ14
GR6- 12KV- 300S AX	6%	300	221.6	14.43	805	350	790	510	240	φ14
GR6- 12KV- 400S AX	6%	400	295.7	19.25	820	360	820	520	260	φ14
GR6- 12KV- 450S AX	6%	450	332.1	21.65	820	360	820	520	260	φ14
GR6- 12KV- 500S AX	6%	500	369.5	24.06	850	380	870	540	260	φ14
GR6- 12KV- 600S AX	6%	600	443.3	28.87	850	380	880	540	280	φ14
GR6- 12KV- 750S AX	6%	750	554.1	36.08	850	380	880	540	280	φ14
GR6- 12KV- 900S AX	6%	900	664.9	43.30	895	380	930	570	280	φ14

■ 成品识别码 (Product Identification Code)

GR — 0037 — 1M73 — 0.4SAL

中压电抗器 额定电流 电感量

Medium voltage reactor Rated Current Inductance

0.4: Working Voltage
0.2=220V, 0.4=380V, 0.7=690V, 1.1=1140V
S: Single Phase Reactor
S=Three Phase Reactor
C: Copper
A: Aluminium

水冷电抗器 (WCR) Water-cooled reactor

■ 产品概述 (Product Introduction)

水冷电抗器主要用于高温系统中，它不仅能够达到普通电抗器的各项性能指标，而且水冷电抗器采用水冷循环，提高耐热温度材料效率从而来适应高温环境要求。

水冷电抗器主要用于高温系统中，它不仅能够达到普通电抗器的各项性能指标，而且水冷电抗器采用水冷循环，提高耐热温度材料效率从而来适应高温环境要求。

Water-cooled reactor is mainly used in high-temperature system, it can not only achieve the performance of ordinary reactor, and water-cooled reactor using water-cooled cycle, improve the efficiency of heat-resistant materials to adapt to high temperature environment requirements.

Water-cooled reactor is mainly used in high-temperature system, it can not only achieve the performance of ordinary reactor, and water-cooled reactor using water-cooled cycle, improve the efficiency of heat-resistant materials to adapt to high temperature environment requirements.

电流范围 Current Range: 100-1500A

电压范围 Voltage Range: 220V-1140V

■ 成品识别码 (Product Identification Code)



风水冷电抗器 (WWR) Wind Water-cooled reactor

■ 产品概述 (Product Introduction)

风冷+水冷电抗器是一种结合空气冷却（风冷）和液体冷却（水冷）技术的混合冷却方式电抗器，其设计目的是兼顾两种冷却方式的优势，提高散热效率，适应高功率密度或复杂工况需求。

Air cooled+water-cooled reactor is a hybrid cooling method reactor that combines air cooling (air-cooled) and liquid cooling (water-cooled) technologies. Its design aims to balance the advantages of both cooling methods, improve heat dissipation efficiency, and adapt to high power density or complex working conditions.

风冷部分通过自然对流或强制风扇驱动空气流动，带走电抗器绕组和铁芯的热量。

The air-cooled part drives air flow through natural convection or forced fans, taking away the heat from the reactor windings and iron core.

电流范围 Current Range: 100-1500A

电压范围 Voltage Range: 220V-1140V

■ 成品识别码 (Product Identification Code)

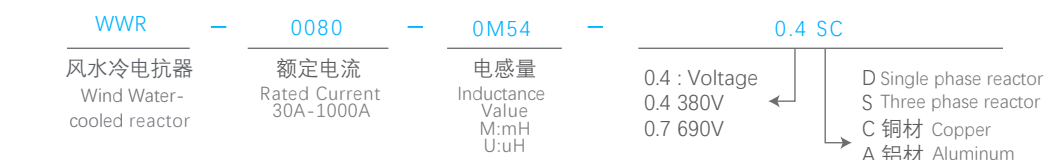

空心电抗器 (HAR) Core Reactor

■ 产品概述 (Product Introduction)

采用高品质的环氧树脂真空浸渍，并高温固化。该产品具有节能、电感线性度好，电抗值精确、线圈温升分布均匀、动热稳定性能高，抗短路、过载能力强，绝缘强度高，电磁场均匀性好，损耗低，温升低使用寿命长，基本免维护，噪声低，阻燃、无污染体积小、重量轻和安装运用使用方便等特点。

It applies the high quality epoxy resin vacuum impregnation, solidification through high temperature. The product has the features of energy saving, good inductive performance, accurate resistance value, uniform distribution of coil temperature rise, high dynamic thermal stability, anti-short circuit, strong overload ability, good insulation intensity, good uniform distribution of electromagnetic field, low loss, low temperature rise, long service life, maintenance-free, low noise, flame-retardant, pollution-free, small size, light weight, and easy to installation and use and so

■ 产品应用 (Product Application)

一般用于配电线路。从同一母线引出的分支馈线上往往串有空心限流电抗器，以限制馈线的短路电流并维持母线电压，不致因馈线短路而致过低。并在其表面进行耐候涂层处理：喷涂具有高绝缘电阻和憎水性的室温硫化硅橡胶(RTV),利用RTV胶的优良绝缘性能，使电抗器沿面电阻保持较好的绝缘性能，对电抗器产品表面树枝状放电现象具有很好的抑制作用。从而保证空心限流电抗器在户外环境下安全运行。该产品应用计算机进行电磁优化计算和空间三维结构设计，采用环氧玻纤增强的多包封并联结构、使用先进的工艺技术和微机控制的生产设备及引进的检验设备进行生产和检验。该产品具有电感线性好、损耗低、温度分布均匀、绝缘强度高、机械强度高、局放小、噪音低、体积小、重量轻、防潮、阻燃、过载能力强、可靠性高、无污染、免维护、环境效果好等优点。

Generally used for distribution lines. Hollow current limiting reactors are often connected in series on branch feeders from the same busbar to limit the short-circuit current of the feeder and maintain the busbar voltage, so as not to be too low due to feeder short circuits. And weather resistant coating treatment is applied to its surface: spraying room temperature vulcanized silicone rubber (RTV) with high insulation resistance and hydrophobicity, utilizing the excellent insulation performance of RTV rubber to maintain good insulation performance along the surface resistance of the reactor, and effectively suppressing the dendritic discharge phenomenon on the surface of the reactor product. Thus ensuring the safe operation of hollow current limiting reactors in outdoor environments. This product uses computers for electromagnetic optimization calculations and spatial 3D structure design. It adopts a multi encapsulated parallel structure reinforced with epoxy fiberglass, advanced process technology, microcomputer controlled production equipment, and imported inspection equipment for production and inspection. This product has the advantages of good inductance linearity, low loss, uniform temperature distribution, good insulation strength, high mechanical strength, small partial discharge, low throat sound, small size, light weight, moisture-proof, flame retardant, strong overload capacity, high reliability, pollution-free, maintenance free, and good environmental

电流范围 Current Range: 30-1600A

电压范围 Voltage Range: 220-35KV

■ 成品识别码 (Product Identification Code)

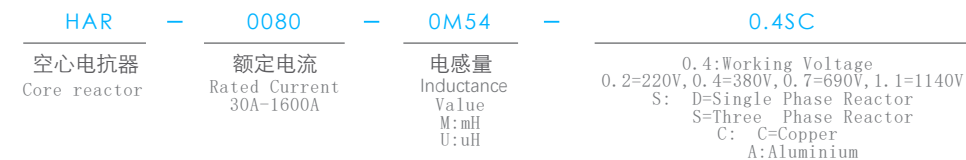

高频电抗器 (HER) High frequency Reactor

产品概述 (Product Introduction)

在现代电力电子设备中随着设备中功率及开关频率的不断提高，中高频大电流电抗器的需求和应用因此越来越多，结合我们的专有技术和行业经验，在此类电抗器的设计和制造中，我们通过磁芯和导体发热的合理选择，处理以及反复验算，保证了电抗器在高频大电流条件下的高性能运行。目前此类产品广泛应用于UPS和新能源等领域的变流器中。开关频率达40KHz

In modern power electronic equipment with the continuous improvement of equipment in the power and switching frequency and high frequency in large current reactor, so more and more application needs and, combined with our proprietary technology and industry experience, in this kind of reactor design and manufacturing, we through the core and the conductor heating reasonable choice, handling, and repeatedly check, ensure the reactor under the condition of high frequency large current high performance operation. At present this kind of products are widely used in UPS and inverter in the field of new energy and so on. Switching frequency of 40 KHZ

产品应用 (Product Application)

目前此类产品广泛应用于UPS, APF和新能源等领域的变流器中
 电流范围 Current Range: 5-500A
 电压范围 Voltage Range: 220V-1140V

软磁材料性能对照表 (Reference Table of Soft Magnetic Material Properties)

材料特性 Property	材料成份 Composition	铁心损耗 Core Loss (mW/cm ³) @1000Gs/50kHz	直流偏压 DC-Bias(%μo) @100 Oe	磁通密度 Flux Density (Sat.)	耐温 Curie Temp.	温度 稳定性 Temp Stability	颜色 代码 Color Code	相对成本 Relative cost
铁粉 Iron Powder	99%Fe	2000	40	12000Gs	750°C	Medium	Mix Color	0.3
铁硅铝 Sendust	85%Fe,9%Si,6%AL	300	45	10500Gs	600°C	Good	Black	1
硅铁 Si-Fe	94Fe,6%Si	750	70	16000Gs	700°C	Good	Blue	1.5
高磁通铁镍 High Flux	50%Fe,50%Ni	400	70	15000Gs	500°C	Better	Khaki	4
铁镍铝 MPP	17%Fe,81%Ni,2%Mo	280	50	7500Gs	400°C	Best	Gray	6
高温超导体 Amorphous Powder Cores	78%Fe,9%Si,13%B	420	68	15000Gs	400°C	Poor	-	3.5
铁硅镍 Neu Flux	85%Fe,15%Si-Ni	480	78	16000Gs	650°C	Better	Brown	2

备注：其他规格尺寸，可根据用户要求制造。 Remark: Dimension can be customization

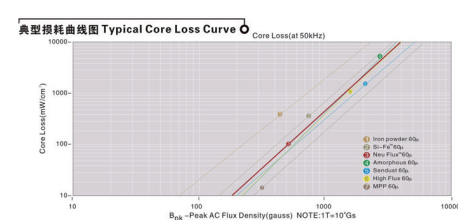
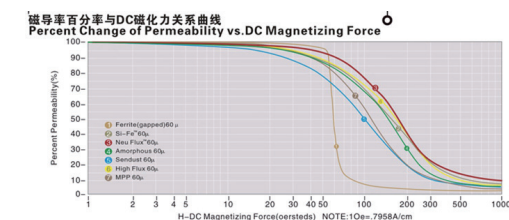

成品识别码 (Product Identification Code)

HER - 0080 - 0M54 - 0.4 SC

高频电抗器 High frequency reactor
 额定电流 Rated Current 30A-1000A
 电感量 Resistance Value M: mH U: uH
 0.4 : voltage 0.4 380V 0.7 690V
 D single phase reactor S Three phase reactor C Cu material A Aluminum material

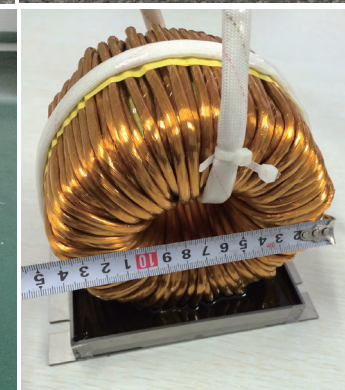
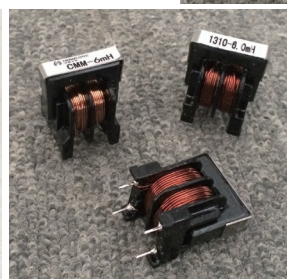
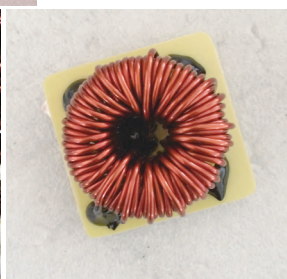
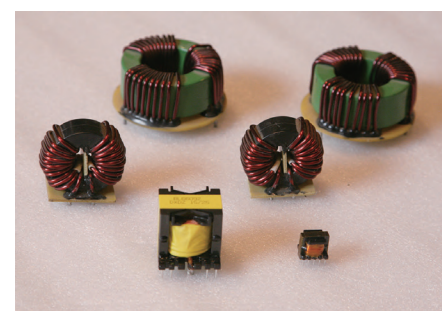
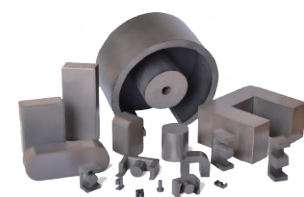
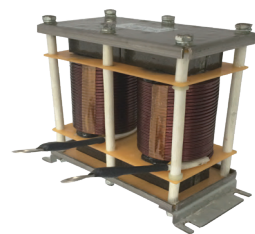

高频电感 High-frequency inductance

为您设计，制造专业的高频电感，详情请致电我们。

our designs and manufactures the most professional high-frequency inductors for you. For more details, please call us.

变频器专用滤波器 Special Filter For Inverter

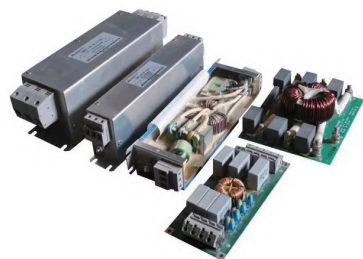

产品概述 (Product Introduction)

- 1.降低变频器对电网的传导干扰
- 2.在150kHz~30MHz范围内拥有优越的插入衰减表现
- 3.端子系列采用紧凑超薄设计
- 4.提高整个系统可靠性
- 5.N99为使用铜排接头, 其他为端子
- 6.端子为铜排以及后缀P系列的滤波器为高泄漏电流, 适合过证测试使用, 但不适用于有漏电保护器场合。
- 7.铜排以及后缀P系列的滤波器在电网电压不平衡及电容精度造成最大漏电流为33mA (400VAC/50Hz)

- 1.Reducing the conducted emission from inverter to power network.
- 2.Exceptional attenuation performance from 150kHz~30MHz.
- 3.Terminal series filter with most compact and slim design.
- 4.Improve the reliability of the whole system.
- 5.N99 uses copper bar connectors, while others are terminals
- 6.Terminals for copper and suffix P series of filter for high leakage currents, suitable for testing use, but does not apply to leakage protector occasions
- 7.Copper bar and filter the suffix P Series in non symmetrical and capacitance tolerance caused maximum leakage current is 33mA (400VAC/50Hz)

技术参数 (Technical Data)

- 1.额定电压: 440/250 VAC
- 2.工作频率: 50Hz
- 3.额定电流: 10A~2500A
- 3.高压试验: P-E 2100VDC/2sec P-P 2100VDC/2sec
- 4.温度范围: -25℃~100℃ (25/100/21)
- 5.设计依据: IEC/EN 60939、UL1283
- 6.典型滤波频率: 150kHz~30MHz

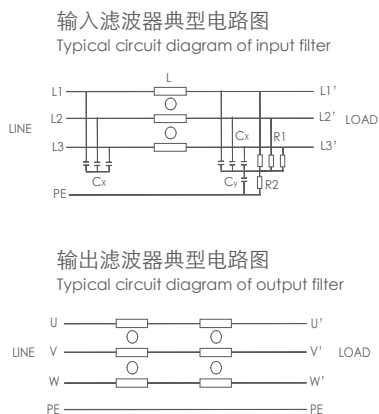

- 1.Rated voltage: 440/250 VAC
- 2.Operating frequency: 50Hz
- 3.Rated current: 10A~2500A
- 3.High potential test voltage: P-E 2100VDC/2sec P-P 2100VDC/2sec
- 4.Temperature range: -25 C~100 C (25/100/21)
- 5.Design corresponding to: IEC/EN 60939、UL1283
- 6.Typical work frequency: 150kHz~30MHz

典型应用 (Typical Applications)

- 1.三相调速电机驱动、伺服驱动、变频器及逆变器
- 2.能量转换装置, 如机器及自动化设备
- 3.空调设备, 电梯, 电力供应, UPS, 注塑机
- 4.风能, 太阳能等新能源逆变系统
- 1.Three-phase variable speed motor drives, servo drives, inverter and converters
- 2.Energy conversion devices, such as machines and automatic equipment
- 3.HVAC equipment, elevators, power suppliers, UPS, injection molding machine and further three-phase applies
- 4.Wind energy, solar energy and other new energy inverter system

滤波器选型表 (Filter Selection Table)

适配变频器参数 Adapter inverter parameter		滤波器型号 Filter type		额定电流 Rated current	端子代码 Connector code
功率 Drive power rating	额定电压 Rated voltage	输入滤波器 Input filter	输出滤波器 Output filter		
5.5kW	440VAC	RFI4C10N6	RFI4C10N6P	10A	-N6
7.5kW	440VAC	RFI4C20N6	RFI4C20N6P	20A	-N6
15kW	440VAC	RFI4C30N10	RFI4C30N10P	30A	-N10
18.5kW	440VAC	RFI4C40N10	RFI4C40N10P	40A	-N10
22kW	440VAC	RFI4C50N16	RFI4C50N16P	50A	-N16
30kW	440VAC	RFI4C65N16	RFI4C65N16P	65A	-N16
37kW	440VAC	RFI4C80N35	RFI4C80N35P	80A	-N35
45kW	440VAC	RFI4C100N35	RFI4C100N35P	100A	-N35
55kW	440VAC	RFI4C130N50	RFI4C130N50P	130A	-N50
90kW	440VAC	RFI4C180N95	RFI4C180N95P	180A	-N95
75kW	440VAC	RFI4C150N99	RFI4C150N99	150A	
110kW	440VAC	RFI4C200N99	RFI4C200N99	200A	
132kW	440VAC	RFI4C250N99	RFI4C250N99	250A	
160kW	440VAC	RFI4C320N99	RFI4C320N99	320A	
220kW	440VAC	RFI4C400N99	RFI4C400N99	400A	
315kW	440VAC	RFI4C600N99	RFI4C600N99	600A	
400kW	440VAC	RFI4C800N99	RFI4C800N99	800A	
560kW	440VAC	RFI4C1000N99	RFI4C1000N99	1000A	
900kW	440VAC	RFI4C1600N99	RFI4C1600N99	1600A	
1320kW	440VAC	RFI4C2500N99	RFI4C2500N99	2500A	

输入滤波器插入损耗 (Input Filter Attenuation)

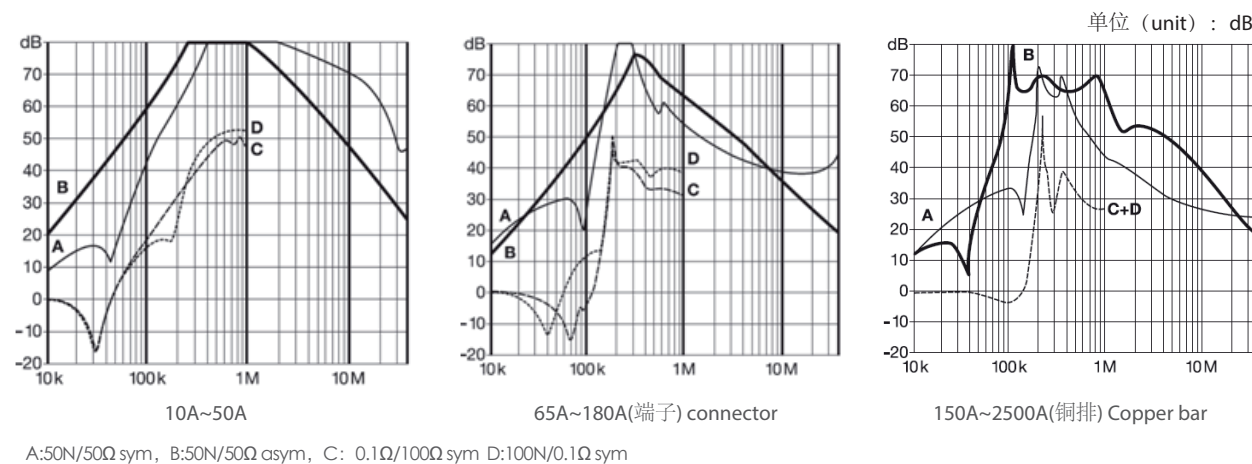

滤波器输入输出端子接线范围及扭矩选择 (Filter Input/output Connector Cross Sections)

	-N6	-N10	-N35	-N35	-N50	-N95
多股软线/mm ² Flex wire	0.5~6	0.5~10	1~16	10~35	16~50	25~95
美标线规 AWG number	AWG8-26	AWG6-24	AWG4-20	AWG2-8	AWG6-1/0	AWG4-4/0
推荐扭矩/N.m Recommended torque	1.36	1.36	2.71	4.41	4.41	19.2

■ 产品尺寸图 (Product Size)

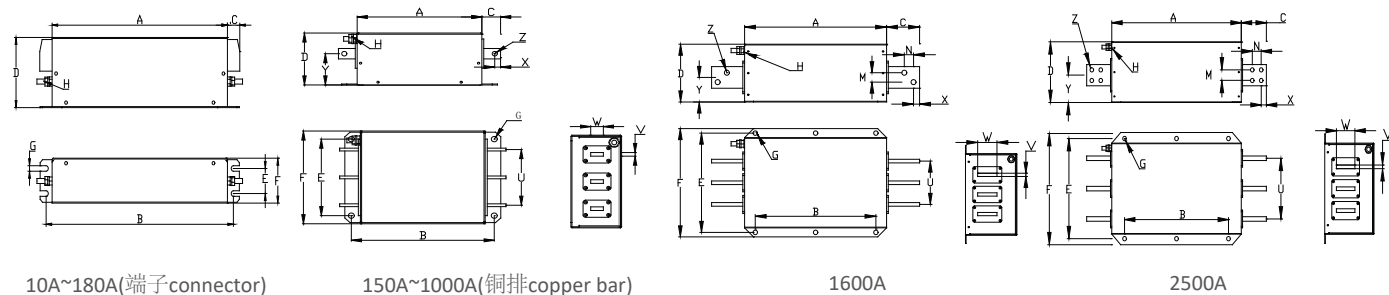

代号 Code 电流 Current	A	B	C	D	E	F	G	H	M	N	U	V	W	X	Y	Z
10A	168	180	15.5	75	20	40	4.5	M5								
20A	220	235	15.5	75	25	45	5.5	M5								
30A~40A	240	255	35	85	30	50	5.5	M5								
50A~65A	220	235	35	90	60	85	5.5	M6								
80A~100A	240	255	38.5	140	60	85	6.5	M8								
130A	240	255	43	150	65	95	6.5	M8								
180A	350	365	50	170	102	120	6.5	M8								
150A~250A	240	275	40	100	165	205	11.5	M10			120	3	20	10	51.5	9
320A								M10			120	4	25	12.5	51.5	11
400A								M10			120	6	25	12.5	51.5	11
600A								M10			120	8	25	12.5	51.5	11
800A	310	345	50	130	155	205	11.5	M10			120	6	40	20	68.5	13.5
1000A								M10			120	8	40	20	68.5	13.5
1600A	400	340	93	160	275	300	12.5	M12	26	26	120	10	60	17	68	14
2500A	600	500	98	200	330	370	14.5	M12	35	35	200	15	70	20	90	14

(单位 unit: mm)

■ 成品识别码 (Product Identification Code)

RFI	—	4NC	—	250	—	N99
变频器专用滤波器 Special Filter For Inverter RFI: Input filter RFO: Output filter		4: Working Voltage 4=380V, 7=690V N: N=Three-phase four-wire 无=Three-phase three-wire C: C=Three-stage filtering B: Second-order filtering		额定电流 Rated Current 10A-2500A		接线方式 Connection mode

三相四线滤波器 3-phase + Neutral Line Filters

■ 产品概述 (Product Introduction)

- 1.降低整个系统对电网的传导干扰
 - 2.在150kHz~30MHz范围内拥有优越的插入衰减表现
 - 3.设计紧凑, 优化工业设计
 - 4.系统进线安装该系列的滤波器, 可以提高整个系统可靠性
 - 5.N99为使用铜排接头, 其他为端子
- 1.Reducing the conducted emission from inverter to power network.
 - 2.Exception attenuation performance from 150kHz~30MHz
 - 3.Compact, space-saving design, optimized for industrial machinery
 - 4.Increases also the immunity if operated directly on the mains input
 - 5.N99 uses copper bar connectors, while others are terminals



■ 技术参数 (Technical Data)

- 1.额定电压: 440/250 VAC
 - 2.工作频率: 50Hz
 - 3.额定电流: 10A~600A (@50°C)
 - 3.高压试验: P-E 2100VDC/2sec P-P 2100VDC/2sec
 - 4.温度范围: -25°C~100°C (25/100/21)
 - 5.设计依据: IEC/EN 60939、UL1283
 - 6.典型滤波频率: 150kHz~30MHz
- 1.Rated voltage: 440/250 VAC
 - 2.Operating frequency: 50Hz
 - 3.Rated current: 10A~600A (@50°C)
 - 3.High potential test voltage: P-E 2100VDC/2sec P-P 2100VDC/2sec
 - 4.Temperature range: -25°C~100°C (25/100/21)
 - 5.Design corresponding to: IEC/EN 60939、UL1283
 - 6.Typical work frequency: 150kHz~30MHz

输入滤波器典型电路图
Typical circuit diagram of input filter

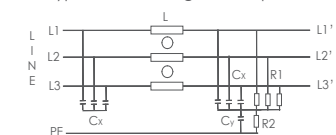

输出滤波器典型电路图
Typical circuit diagram of output filter

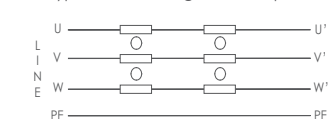

■ 典型应用 (Typical Applications)

主要应用于工业设备, 机械, 机床及其他自动化控制的三相四线电力系统。由于出色的性能衰减, 该系列滤波器也是嘈杂的电源的首选, 应用于可再生能源、大功率的办公设备和其他三相四线的设备。因为相对较低的漏电流, 该系列滤波器甚至可以用于一些医疗设备。

Mainly industrial equipment, machinery, machinetools and diverse process automation systems with three-phase and neutral electricity supply. Due to the outstanding attenuation performance, The series is also the first choice for noisy power supplies, renewable energy applications, high power office equipment and further three-phase and neutral devices. Because of the relatively low leakage current, The series may even be used for some medical devices.

■ 输入滤波器插入损耗 (input filter attenuation)

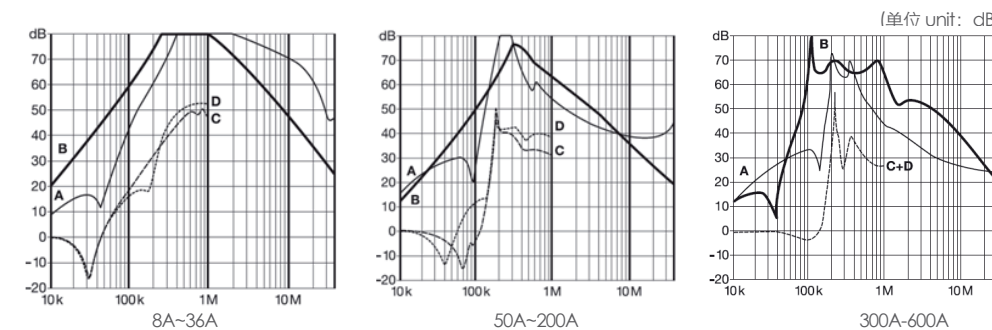

A:50N/50Ω sym, B:50N/50Ω asym, C: 0.1Ω/100Ω sym D:100N/0.1Ω sym

■ 滤波器选型表 (Filter Selection Table)

滤波器型号 Filter type	额定电流 Rated current @40°C [A]	漏电流 Leakage current @230VAC/50Hz [mA]	能量损耗 Power loss @25°C/50Hz [W]	端子类型 Connector type
RFI4NC8N06	8	<1	3.2	端子 solid safety connector
RFI4NC16N06	16	<1	6.5	端子 solid safety connector
RFI4NC25N10	25	<1	11.8	端子 solid safety connector
RFI4NC36N10	36	<1	15.3	端子 solid safety connector
RFI4NC50N16	50	<1	17.4	端子 solid safety connector
RFI4NC65N16	65	<1	18.9	端子 solid safety connector
RFI4NC100N35	100	<1	23.6	端子 solid safety connector
RFI4NC130N50	130	<1	28.5	端子 solid safety connector
RFI4NC160N95	160	<1	31	端子 solid safety connector
RFI4NC200N95	200	<1	47.4	端子 solid safety connector
RFI4NC300N99	300	<1	20.3	铜排 copper bar
RFI4NC400N99	400	<1	36	铜排 copper bar
RFI4NC600N99	600	<1	64.8	铜排 copper bar

■ 产品尺寸图 (Product Size)

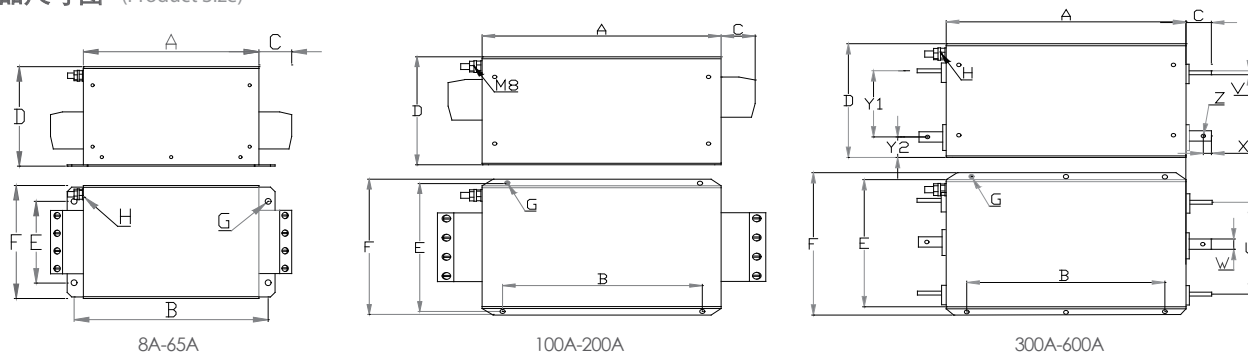

代号 Code 电流 Current	A	B	C	D	E	F	G	H	U	V	W	X	Y1	Y2	Z
8A~16A	160	180	15.5	80	65	100	5.5	M5							
25A~36A	160	180	35	100	75	115	5.5	M5							
50A~65A	190	210	35	110	90	125	6.4	M6							
100A	230	120	38.5	125	150	163	6.4	M8							
130A	250	200	43	140	157	170	6.4	M8							
160A~200A	280	220	52	170	166	180	6.4	M8							
300A	325	240	58	150	195	220	11	M10	120	4	25	12.5	72	43	11
400A	325	240	58	150	195	220	11	M10	120	6	25	12.5	72	43	11
600A	325	240	58	150	195	220	11	M10	120	8	25	12.5	72	43	11

(单位 unit: mm)

■ 滤波器输入输出端子接线范围及扭矩选择 (Filter Input/output Connector Cross Sections)

	-N6	-N10	-N16	-N35	-N50	-N95
多股软线/mm ² Flex wire	0.5~6	0.5~10	1~16	10~35	16~50	25~95
美标线规 AWG number	AWG8-26	AWG6-24	AWG4-20	AWG2-8	AWG6-1/0	AWG4-4/0
推荐扭矩/N.m Recommended torque	1.36	1.36	2.71	4.41	4.41	19.2

单相滤波器 1-phase filter

■ 产品概述 (Product Introduction)

1. 具有高衰减性能的通用滤波器
2. 具有良好的共模差模滤波性能
3. 广泛应用于开关电源, UPS, 变频逆变等场合
4. 超过50A一定要确保接地良好, 否则有电击危险
5. 医用型的滤波器后缀为A

1. General purpose EMI filter with high attenuation performance
2. High common-mode and differential-mode attenuation
3. Widely used in switching power, UPS, inverter, etc.
4. Exceed 50A must ensure that the ground is good, otherwise there is a risk of electric shock
5. Medical type filter suffix for A



■ 技术参数 (Technical Data)

额定电压: 250 VAC
 工作频率: 0~60Hz
 额定电流: 3A~200A
 高压试验: P/N-E 2000VAC/2sec θP-N 1100VDC/2sec
 温度范围: -25°C~85°C (25/85/21)
 设计依据: IEC/EN 60939
 典型滤波频率: 150kHz~30MHz
 Rated voltage: 250 VAC
 Operating frequency: 0~60Hz
 Rated current: 3A~200A
 High potential test voltage: OP/N-E 2000VAC/2sec OP-N 1100VDC/2sec
 Temperature range: -25°C~85°C (25/85/21)
 Design corresponding to: IEC/EN 60939
 Typical work frequency: 150kHz~30MHz

■ 典型应用 (Typical Applications)

1. 电气和电子设备
2. 消费品
3. 家庭设备
4. 电子数据处理设备
5. 办公自动化和数据通信设备
6. 电磁环境恶劣且需要高性能滤波滤波器

Electrical and electronic equipment
 Consumer goods
 Household equipment
 Electronic data processing equipment
 Office automation and datacom equipment
 Various noisy applications requiring high filter performance

典型电路图
typical electrical schematic

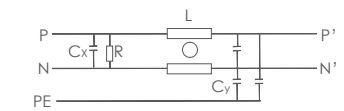

■ 输入滤波器插入损耗 (Input Filter Attenuation)

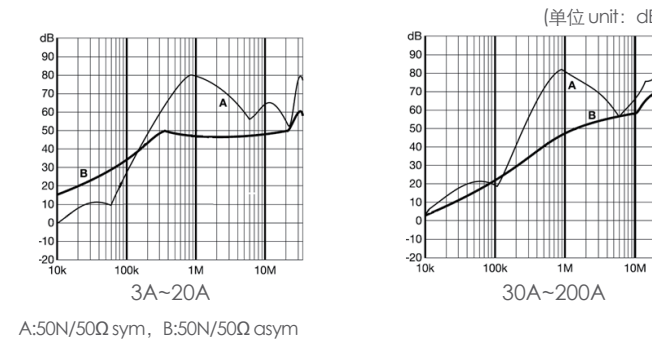

■ 滤波器选型表 (Filter Selection Table)

滤波器型号 Filter type		额定电流 Rated current @40°C [A]	漏电流 Leakage current @230VAC/50Hz [mA]		能量损耗 Power loss @25°C/50Hz [W]	端子类型 Connector type
通用型 Universal filter	医用型 Medical filter		通用型 Universal filter	医用型 Medical filter		
RFD2B3N01	RFD2B3N01A	3	0.87	0.074	2.3	
RFD2B6N01	RFD2B6N01A	6	0.87	0.074	3.2	
RFD2B10N01	RFD2B10N01A	10	0.87	0.074	3.8	
RFD2B16N01	RFD2B16N01A	16	0.87	0.074	4.7	
RFD2B20N01	RFD2B20N01A	20	0.87	0.074	5.6	
RFD2B30N05	RFD2B30N05A	30	0.87	0.074	8.5	
RFD2B50N05	RFD2B50N05A	50	1.75	0.074	13.3	
RFD2B100N05	RFD2B100N05A	100	1.75	0.074	30.2	
RFD2B200N05	RFD2B200N05A	200	3.5	0.074	46.9	

■ 产品尺寸图 (Product Size)

(单位 unit: mm)

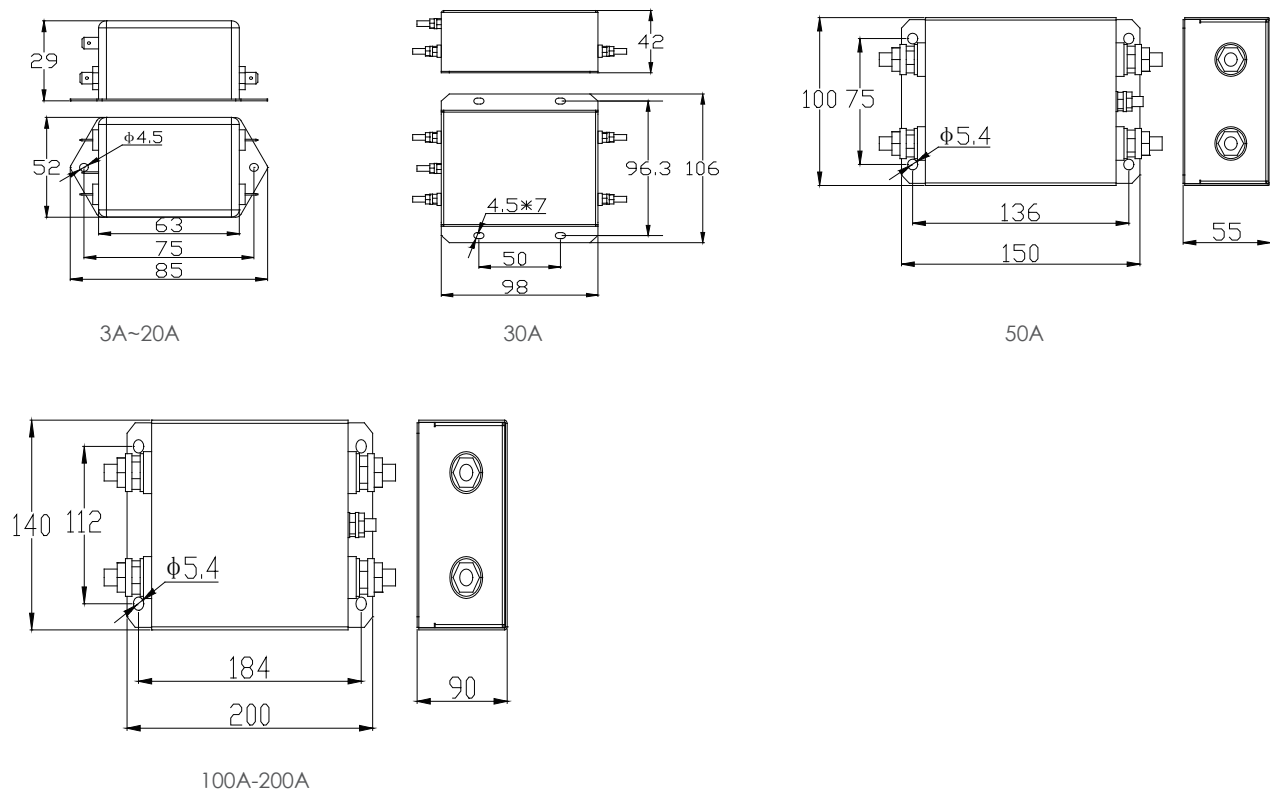

■ 成品识别码 (Product Identification Code)



线噪声滤波器 (RF) Line noise filter

■ 产品概述 (Product Introduction)

有效抑制伺服放大器电源侧或输出侧产生的无线电干扰, 也可抑制高频漏电流 (零相电流)。在 0.5MHz-5MHz 范围尤其有效。

Effectively suppress radio interference generated on power supply side or output side of the servo amplifier, and also suppress high-frequency leakage current (zero phase current). Especially effective in the range of 0.5MHz-5MHz.

■ 技术规格 (Technical Specifications)

品名 Product Name	尺寸 Size (±1mm)				Ae (mm ²) TYP	Lm (mm ²) TYP	重量 Picture	AL (uH/N ² ± 35%)			
	A	B	C	D				10KHZ	100KHZ		
RF-BFS01	65	15	42	50	18.3	6.5*11	121	78.1	60	13.8~23.1	18.5
RF-BFS02	65	20	47	50	22	6.5*11	175	91.7	98.4	16.1~26.8	21.5
RF-BFS03	80	19	57	65	30	6.5*11	186	120	140	17.0~28.4	17.4
RF-BFS04	110	25	70	95	38	6.5*11	305	152	280	13.1~24.3	22.7
RF-BFS05	135	20	88	115	40	6.5*11	384	174	425	12.4~20.8	16.6
RF-BFS06	170	18	115	155	65	6.5*11	371	260	400	8.5~14.1	11.3

品名 Product Name	尺寸 Size (±1mm)				Ae (mm ²) TYP	Lm (mm ²) TYP	重量 Picture	AL (uH/N ² ± 35%)					
	A	B	C	D				10KHZ	100KHZ				
RF-BFL01	50	25.5	44.3	40	22.2	25	8.4	5*5	212	89	115	4.5~7.5	6.0
RF-BFL02	160	25.4	106.6	140	50.8	114.2	63.4	6.5*11	645	308	1200	3.8~6.3	5.0
RF-BFL03	180	30	85	160	37	130	86	6.5*11	647	314	1450	3.6~6.0	4.8
RF-BFL04	220	40	125	190	59	160	101	8.5*14	1200	421	3100	5.2~8.6	6.9
RF-BFL05	250	39	145	220	60	190	113.2	8.5*14	1548	497	4200	5.3~8.8	7.0
RF-BFL06	310	40	166	280	78	240	160	8.5*14	1577	597	5000	4.4~7.3	5.8

备注: 本产品符合UL94V-0认定的数值 (耐热温度130°C), 本产品不含有臭氧层破坏物质ODC, 在制造过程中也没有使用臭氧层破坏物质ODC

This product meets the UL94V-0 certification value (heat-resistant temperature of 130 °C), This product does not contain ozone depleting substances (ODCs), and no ODCs were used during the manufacturing process

Ae: 有效截面积, Lm: 平均磁路长
Ae: effective cross-sectional area, Lm: average magnetic path length

■ 产品尺寸图 (Product Size)

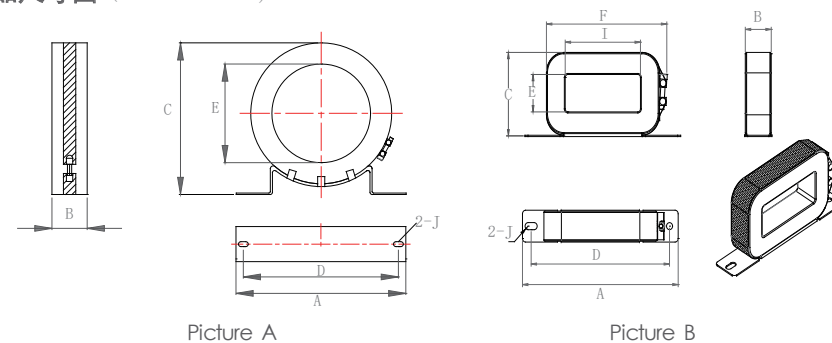

■ 成品识别码 (Product Identification Code)



典型电路图

(Typical circuit diagram)

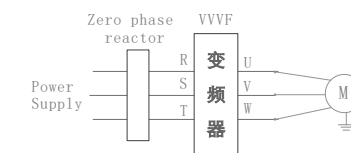

注) 将电源线在零相电抗器处卷成4匝以上
在输出端也需要同样适用。
Note) Roll the power cord into more than 4 turns at the zero phase reactor
It also needs to be applicable at the output end.

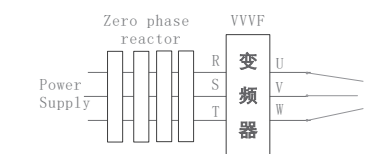

注) 请勿直接贯通使用。(4个以上)

根据所使用的电缆的种类、尺寸不同, 存在无法使用的场合。

Note) Please use without rolling directly. (4 or more)

400V and above 200KW models, please use RF-BFL series

Depending on the type and size of cable used, there may be situations where it cannot be used.

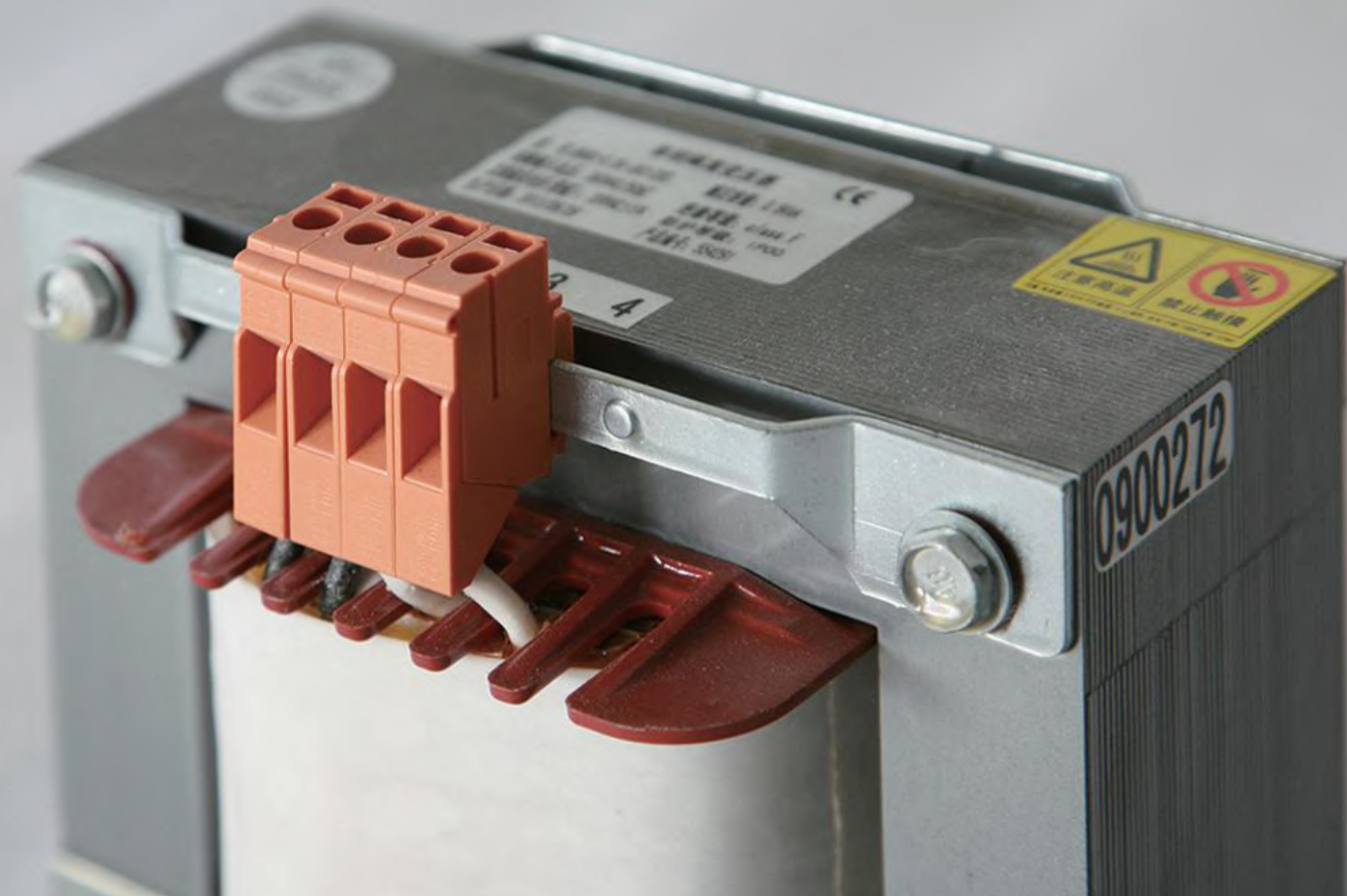

变压器 Transformer

单/三相隔离变压器 (BKSC)

Single/Three-phase Isolation transformer

■ 产品概述 (Product Introduction)

该类隔离变压器的目的是提供负载和电源侧之间的电隔离，在IT配电系统中，防止电冲击，以保护所连接设备的绝缘损坏，还提供中性点连接形成隔离或接地。通过初次级间与连接的静电屏蔽及加强的绝缘，该类隔离变压器能提供敏感负载的隔离以防止电源系统遭受严峻的大气干扰。另外，利用其铁芯的高频损耗大的特点，从而抑制高频杂波传入控制回路。

The purpose of such isolation transformers is to provide electrical isolation between the load and the power supply, prevent electric shock in the IT distribution system so as to protect the insulation of the device connected from being damaged, and provide neutral point connection for isolation or grounding. Through the shielding between the primary and secondary levels and the static electricity connected as well as reinforced insulation.

■ 产品特点 (Product Features)

我公司多年来采用优质材料和先进的工艺技术专业生产 160VA--800KVA 之间，单/三相干式隔离变压器，产品参照国外同类产品最新研制开发进口设备用变压器，广泛适用于交流 50/60HZ，输入、输出电压不超过 1000V 的各种供电场合。产品的各种输入、输出，电压高低，联接组别，调节抽头位置，绕组容量分配，次级绕组配备，是否要求带外壳等，均根据用户的要求进行精心的设计与制造。该系列隔离变压器广泛用于地铁、高层建筑、机车、电梯、车站、印刷、机床、码头、工矿企业及隧道的输配电及进口设备的使用等场所。

Our company has been using high-quality materials and advanced process technology to professionally produce single/three-phase dry-type isolation transformers between 160VA and 800KVA for many years. The products are based on the latest research and development of imported equipment transformers for similar foreign products, and are widely used in various power supply scenarios with AC 50/60HZ and input and output voltages not exceeding 1000V. The various inputs and outputs, voltage levels, connection groups, tap position adjustment, winding capacity allocation, secondary winding configuration, and whether to require a casing of the product are carefully designed and manufactured according to the user's requirements. This series of isolation transformers is widely used in places such as subways, high-rise buildings, locomotives, elevators, stations, printing, machine tools, docks, industrial and mining enterprises, and tunnels for power transmission and distribution, as well as the use of imported equipment.

■ 技术规格 (Technical Specifications)

功率范围 Power Range:	160-800KVA
输入电压 Input Voltage	Rated voltage \leq 1000V \pm 10% Δ /Y
输出电压 Output Voltage	Rated voltage \leq 1000V + 5% (No Load) Δ /Y
效率 Efficiency	\geq 95%
波形失真 Waveform distortion	No additional waveform distortion
功能 Function	With input voltage, output voltage, current indication
保护 protect	Overcurrent protection
绝缘电阻 Insulation resistance	1000VDC insulation resistance value \geq 100M Ω
电气强度 Dielectric strength	Core Coil 3000VAC/50Hz/5mA/10s no electric arcing puncture (factory test)
过载能力 Max Current	2 \times Rated current, continuous 60s

海拔高度不超过 2000 米。
运行环境温度 -25 $^{\circ}$ C ~ +45 $^{\circ}$ C，相对湿度不超过 90%。
周围无有害气体，无易燃易爆物品。
周围环境应有良好的通风条件，如装在柜内，应加装通风设备。

Under seal level 2000m
Running ambient temperature -25 $^{\circ}$ C ~ +45 $^{\circ}$ C, comparative moisture not over 90%.
There are no harmful gases or flammable or explosive materials around.
With well-ventilated condition, ventilation devices shall be mounted if installation in panels



单/三相隔离变压器 (BKSC) Single/Three-phase Isolation transformer	52
自耦变压器 (BYSC) Autotransformer	55
整流变压器 (ZKSC) Rectifier transformer	56
逆变输出变压器 (NKSC) Inverter transformer	56
低压三相干式变压器外壳 Low voltage transformer enclosure	57
JBK3 系列变压器 JBK3 series transformer	58
JBK5 系列变压器 JBK5 series transformer	59
JBK6 系列变压器 JBK6 series transformer	62
JBK7 系列变压器 JBK7 series transformer	64



典型电路图

(Typical circuit diagram)

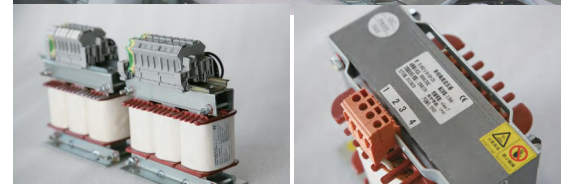
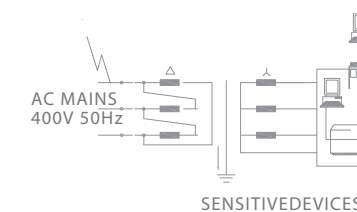

■ 执行标准 (Applicable Standards)

VDE0550、IEC439、JB5555、GB5226

■ 产品尺寸图 (Product Size)

三相隔离变压器 (Three-phase Isolation transformer)

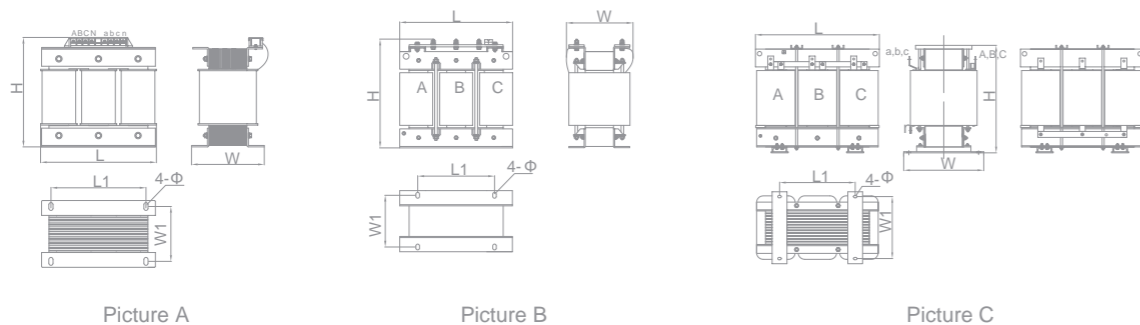

型号规格 TYPE	容量(kVA) Capacity	图号 Picture NO.	绝缘等级 Insulation rank	外形尺寸(±5mm) Dimension			
				L*W*H	安装尺寸(±2mm) Installation L1*W1	安装孔(mm) Mounting holes 4-Φ	
BKSC-0.5K	0.5	图 A Picture A	F, H	150*185*205	100*90	8.5*14	
BKSC-1.0K	1.0		F, H	185*250*270	200*90	11*18	
BKSC-1.5K	1.5		F, H	195*250*270	200*110	11*18	
BKSC-2.0K	2.0		F, H	205*250*270	200*120	11*18	
BKSC-3.0K	3.0		F, H	175*300*310	240*120	11*18	
BKSC-4.0K	4.0		F, H	200*300*310	240*120	11*18	
BKSC-5.0K	5.0		F, H	210*300*310	240*140	11*18	
BKSC-6.0K	6.0		F, H	240*300*310	240*170	11*18	
BKSC-8.0K	8.0		F, H	240*300*310	240*170	11*18	
BKSA-10K	10		图 B Picture B	F, H	250*360*380	300*172	11*18
BKSA-15K	15	F, H		260*460*510	260*144	15*25	
BKSA-20K	20	F, H		290*460*510	260*154	15*25	
BKSA-30K	30	F, H		320*460*510	260*174	15*25	
BKSA-50K	50	F, H		340*460*550	260*230	15*25	
BKSA-70K	70	F, H		420*700*680	520*250	15*25	
BKSA-80K	80	图 C Picture C		F, H	420*700*680	520*250	15*25
BKSA-90K	90			F, H	480*850*820	570*250	15*25
BKSA-100K	100			F, H	480*850*820	570*250	15*25

备注：其他规格尺寸，可根据用户要求制造。 Remark: Dimension can be customization

单相隔离变压器 (Single-phase Isolation transformer)

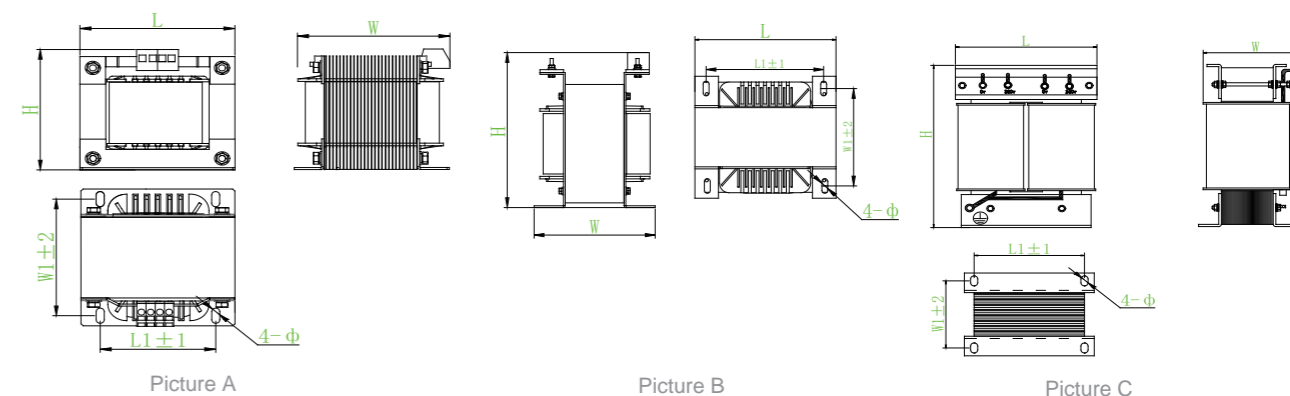

型号规格 TYPE	容量(kVA) Capacity	图号 Picture NO.	绝缘等级 Insulation rank	外形尺寸(±5mm) Dimension		
				L*W*H	安装孔(±2mm) Mounting holes L1*W1	安装孔(mm) Mounting holes 4-Φ
BKDC-0.088K	0.088	图 A Picture A	F, H	106*85*72	90*-	5*8
BKDC-0.15K	0.15		F, H	88*110*90	71.5*78	6*8
BKDC-0.2K	0.2		F, H	100*115*120	80*105	6.5*11
BKDC-0.3K	0.3		F, H	125*130*150	100*84	8*11
BKDC-0.5K	0.5		F, H	125*115*125	85*93	6.5*11
BKDC-0.63K	0.63		F, H	155*135*147	120*105	7*14
BKDC-0.7K	0.7		F, H	155*135*147	120*105	7*14
BKDC-0.8K	0.8		F, H	155*135*147	120*105	7*14
BKDC-1.0K	1.0		F, H	152*140*145	120*120	7*14
BKDC-1.5K	1.5		F, H	152*170*145	120*140	7*14
BKDC-2.0K	2.0	图 B Picture B	F, H	195*195*180	155*155	10*20
BKDC-3.0K	3.0		F, H	195*200*180	155*165	10*20
BKDC-4.0K	4.0		F, H	243*210*260	200*166	10*25
BKDC-5.0K	5.0		F, H	243*210*260	200*166	10*25
BKDC-6.0K	6.0	图 C Picture C	F, H	300*290*400	200*160	11*18
BKDC-8.0K	8.0		F, H	300*290*400	200*160	11*18
BKDC-10K	10		F, H	300*290*400	200*160	11*18

备注：其他规格尺寸，可根据用户要求制造。 Remark: Dimension can be customization

■ 成品识别码 (Product Identification Code)

BKSA	-	10K	-	660	-	380
BK:隔离变压器 Isolation transformer		容量 Capacity		初级电压 Input Voltage		初级电压 Output Voltage
S: D=Single Phase S=Three Phase						
C: C=Copper A:Aluminium						

自耦变压器 (BYSC) Autotransformer

产品概述 (Product Introduction)

自耦变压器用于交流50HZ额定电压308V。功率11~315(KW)三相鼠笼感应电动机的不频繁降压启动,以改善电动机启动时对输电网络的影响。

The autotransformers are used for AC 50HZ at rated voltage 308V. The infrequent partial voltage starting of the three-phase squirrel-cage induction motor of power of between 11 and 315 (KW) is to minimize the impact of the motor on the transmission network at the time of startup.

产品特点 (Product Features)

采用F, H级为基础的绝缘系统, 在自耦变压器的整个使用寿命期都保持极佳的电气性能和机械性能, F, H级材料不易老化, 耐收缩和抗压缩, 加上弹力特强, 因此可以确保变压器使用数年后任保持结构紧密, 并却能够承受短路的压力, 自耦变压器整体由H级浸渍漆在真空压力下浸渍(VPI), 然后再烘箱里高温固化。

It adopts F and H-grade insulation system, and maintains splendid electrical and mechanical performance throughout the life of the autotransformer. The F and H-grade materials are anti-aging, anti-shrinkage and anti-compression with particularly strong elasticity, thus ensuring the compact structure of the transformer after several years of use and the capability to the pressure of short-circuit. The entire autotransformer is macerated in Class H maceration paint under vacuum pressure (VPI), and is cured at high temperature in oven.

技术规格 (Technical Specifications)

功率范围 Power Range:	160-800KVA
输入电压 Input Voltage	Rated voltage $\leq 1000V \pm 10\% \Delta/Y$
输出电压 Output Voltage	Rated voltage $\leq 1000V + 5\%$ (No Load) Δ/Y
效率 Efficiency	$\geq 95\%$
波形失真 Waveform distortion	No additional waveform distortion
功能 Function	With input voltage, output voltage, current indication
保护 protect	Overcurrent protection
绝缘电阻 Insulation resistance	1000VDC insulation resistance value $\geq 100M\Omega$
电气强度 Dielectric strength	Core Coil 3000VAC/50Hz/5mA/10s no electric arcing puncture (factory test)
过载能力 Max Current	2 x Rated current, continuous 60s

海拔高度不超过2000米。
运行环境温度-25℃~+45℃, 相对湿度不超过90%。
周围无有害气体, 无易燃易爆物品。
周围环境应有良好的通风条件, 如装在柜内, 应加装通风设备。

Under seal level 2000m
Running ambient temperature -25 °C ~ +45 °C, comparative moisture not over 90%.
hazardous gas, no inflammables and explosives
With well-ventilated condition, ventilation devices shall be mounted if installation in panels

成品识别码 (Product Identification Code)

BYDA	10K	660	380
BK:隔离变压器 Isolation transformer S: D=Single Phase S=Three Phase C: Copper A:Aluminium	容量 Capacity	初级电压 Input Voltage	初级电压 Output Voltage

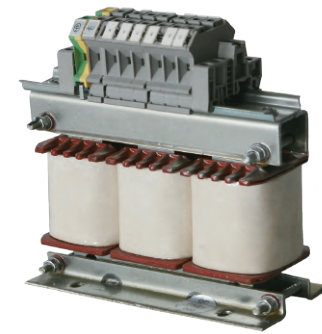

典型电路图
(Typical circuit diagram)

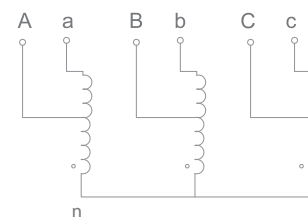

整流变压器
Rectifier transformer



逆变输出变压器
Inverter transformer

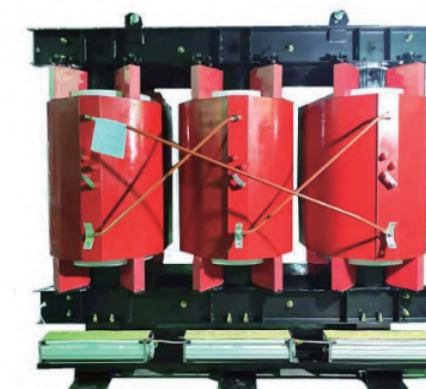

升压变压器
Isolating transformer



移向变压器
Move to the transformer

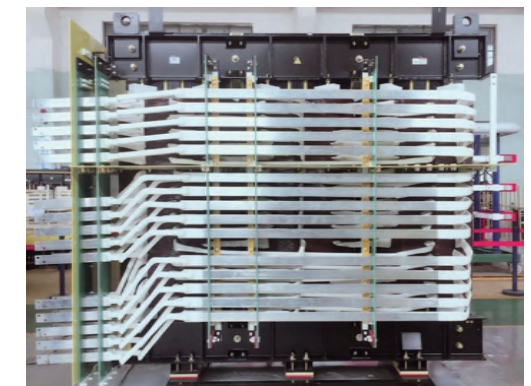

变频调速用干式整流变压器
Dry-type rectifier transformer for frequency conversion speed regulation



隔离变压器
Isolating transformer

SGC系列低压三相干式变压器外壳

SGC series low-voltage three phase dry-type transformer shell

■ 产品概述 (Product Introduction)

SGC系列变压器的外壳主要用于保护变压器内部的绕组、铁芯以及其他电气元件，确保其在各种环境条件下安全稳定运行。

The shell of SGC series transformer is mainly used to protect the windings, iron cores and other electrical components inside the transformer to ensure its safe and stable operation under various environmental conditions.

■ 外形及安装尺寸 (Appearance and installing size)

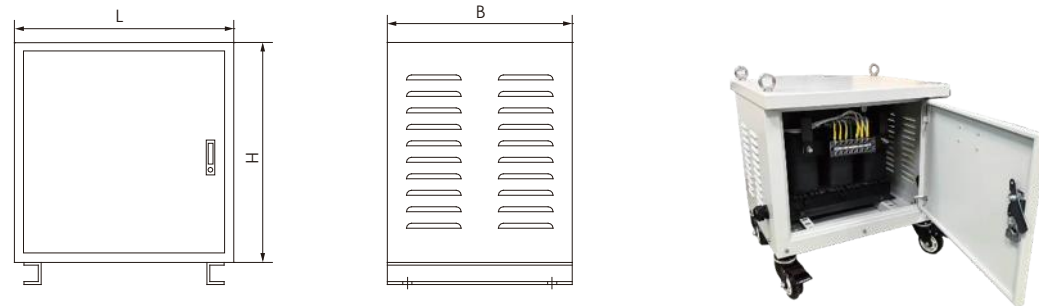

■ 技术数据 (Technical data)

型号 Model	容量 Capacity KVA	外形尺寸 Outline size		
		L	B	H
SGC-2.5KVA	2.5	300	240	280
SGC-3KVA	3	300	240	280
SGC-4KVA	4	390	280	320
SGC-5KVA	5	390	280	320
SGC-6KVA	6	390	280	320
SGC-8KVA	8	500	380	500
SGC-10KVA	10	500	380	500
SGC-12KVA	12	500	380	500
SGC-15KVA	15	500	380	500
SGC-20KVA	20	600	420	580
SGC-25KVA	25	600	420	580
SGC-30KVA	30	600	420	580
SGC-40KVA	40	600	420	580
SGC-45KVA	45	740	500	720
SGC-50KVA	50	740	500	720
SGC-60KVA	60	740	500	720
SGC-80KVA	80	840	530	720
SGC-100KVA	100	840	530	720

■ 成品识别码 (Product Identification Code)

SGS — ■
 低压三相干式变压器外壳
 low-voltage three phase dry-type transformer shell

■
 容量 (VA)
 Capacity (VA)

JBK3系列变压器

JBK3 series transformer

■ 产品概述 (Product Introduction)

JBK3系列变压器适用于交流50/60Hz，输出额定电压不超过220V，输入额定电压不超过500V，作为各行各业的机械设备，一般电器的控制电源和工作照明、信号灯的电源之用。

JBK3 series transformer is applicable to AC 50/60hz, with the rated output voltage not exceeding 220V and the rated input voltage not exceeding 500V. It is used as the control power supply of mechanical equipment in all walks of life, general electrical appliances and working lighting and signal lamps.

■ 技术数据 (Technical data)

型号 Model	长 B Length	宽 D width	高 E height	安装孔距 Hole distance A	安装孔距 Hole distance C	安装孔距 Hole distance K	F max
JBK3-40、63	78	72	89	56±0.4	51±2	4.8	2
JBK3-100	84	85	94	64±0.4	66±2	4.8	2
JBK3-160	96	92	109	84±0.4	73±2	5.8	2
JBK3-250	96	105	109	84±0.4	87±2	5.8	2
JBK3-400	120	109	123	90±0.4	90±2	7	2.5
JBK3-630	150	112	150	122±0.5	90±2	6	2.5
JBK3-1000	160	195	151	130±2	152±2	7	3
JBK3-1600	170	225	163	144±2	176±2	7	3
JBK3-2500	200	250	171	170±2	200±2	7	4

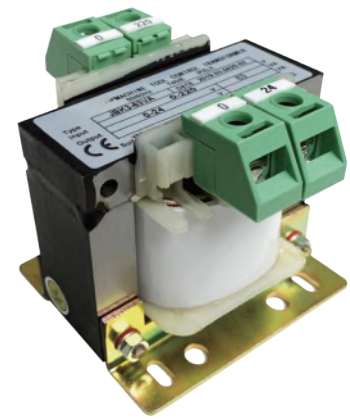

■ 外形及安装尺寸 (Appearance and installing size)

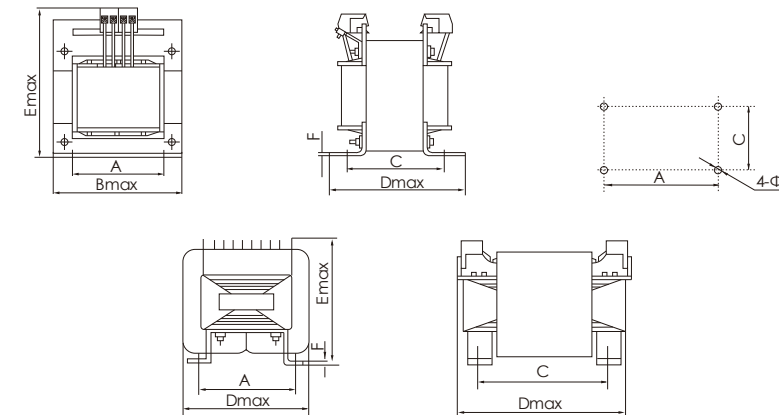

■ 成品识别码 (Product Identification Code)

JB — K3 — ■ / ■
 变压器 transformer 控制 control 容量 (VA) Capacity (VA) 热带产品代号 Tropical product code

湿热带TH 干热带TA
 Hot and humid Dry tropical
 belt TH

JBK5系列变压器

JBK5 series transformer

产品概述 (Product Introduction)

JBK5系列变压器是我公司引进德国90年代中期最新型变压器系列，在国内JBK3系列变压器基础上，经过多年来进一步吸收国外同类产品，并优选国外先进方法的接线端子结构、将端子与骨架合在一起，使防护等级提高到IP2LX，防止偶然触及电路。采用国内IT冷压接线端子，接线方式可以使接线密集程度提高。

Adopting technology of Siemens company, we design and manufacture JSJ series three phase transformer with voltage between 160VA and 16KVA. The figure and installation size have been standardized and can be used together with 4AP series of Siemens.

产品特点 (Product Features)

- 1) 引进德国技术。
- 2) 最高防护等级达到IP2LX，可偶尔停止接触电路。
- 3) 采用冷压连接端子，提高连接强度。
- 4) 采用优质防腐材料，大大提高接地可靠性。
- 5) 用于输入电压500V以下，输出电压220V，频率50/60Hz的机器。
- 6) 符合VDE0550、IEC204-1、IEC439、JB5555、GB5226并经CE认证。

- 1) Bring in technology of Germany.
- 2) Maximum protection grade reach IP2LX, can stop touch circuit occasionally.
- 3) Adopt cold-pressure connection terminal which can improve connection intensity.
- 4) Adopt excellent corrode-proof material, which greatly improve the reliability of earth connection.
- 5) Used for machine with input voltage less than 500V, output voltage 220V and frequency 50/60Hz.
- 6) Comply with VDE0550, IEC204-1, IEC439, JB5555, GB5226 and certificated by CE.

外形及安装尺寸 (Appearance and installing size)

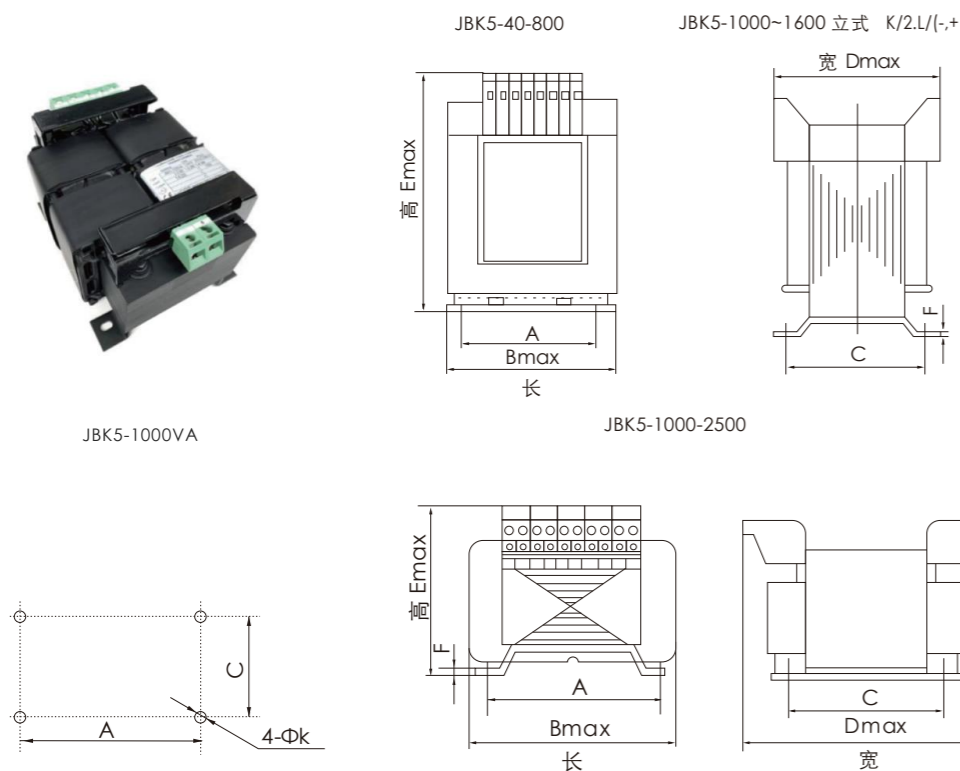

技术数据 (Technical data)

型号 Model	长 B Length	宽 D width	高 E height	安装孔距 Hole distance A	安装孔距 Hole distance C	安装孔径 Hole distance K	F max	备注 Remarks
JBK5-40	78	72	90	56±0.15	46±0.125	4.6	1.5	
JBK5-63	78	72	90	56±0.15	46±0.125	4.6	1.5	
JBK5-100	84	75	96	64±0.15	62±0.15	4.6	1.5	
JBK5-160	96	92	105	84±0.175	73.5±0.15	5.5	1.5	
JBK5-250	96	100	104	84±0.175	85±0.175	5.8	1.5	
JBK5-400	120	100	122	90±0.175	85±0.175	5.8	2	
JBK5-500	120	110	122	90±0.175	96±0.175	5.8	2	
JBK5-630	150	110	140	122±0.2	90±0.175	7	2	
JBK5-800	150	128	142	122±0.2	105±0.2	7	2	
JBK5-1000	150	190	142	130±0.2	152±0.2	7	3	卧式 Horizontal
JBK5-1000	168	125	155	138±0.2	105±0.2	9	2	立式 Vertical
JBK5-1600	170	225	153	144±0.2	176±0.2	7	3	卧式 Horizontal
JBK5-1600	168	138	155	138±0.2	116±0.2	7	2	立式 Vertical
JBK5-2500	194	250	170	170±0.2	200±0.23	7	4	卧式 Horizontal
JBK5-2500	228	200	230	190±1.0	126±1.0	10	4	立式 Vertical
JBK5-3000	194	250	190	170±0.2	200±0.23	7	4	卧式 Horizontal
JBK5-3000	228	210	230	190±1.0	146±1.0	10	4	立式 Vertical
JBK5-4000	194	250	200	170±0.2	200±0.23	7	4	卧式 Horizontal
JBK5-4000	228	240	230	190±1.0	146±1.0	10	4	立式 Vertical
JBK5-5000	220	286	215	208±0.5	240±0.5	9	4	卧式 Horizontal
JBK5-5000	240	225	240	200±1.0	152±1.0	10	4	立式 Vertical
JBK5-6000	220	286	215	208±0.5	240±0.5	9	4	卧式 Horizontal
JBK5-6000	240	240	240	200±1.0	162±1.0	10	4	立式 Vertical
JBK5-7000	220	286	250	208±0.5	240±0.5	9	4	卧式 Horizontal
JBK5-7000	240	240	260	200±0.5	165±0.5	12	4	立式 Vertical
JBK5-8000	270	310	320	225±0.5	205±0.5	12	4	立式 Vertical
JBK5-10000	270	310	320	225±0.5	205±0.5	12	4	立式 Vertical
JBK5-15KVA	330	270	480	290	150	14	5	立式 Vertical
JBK5-20KVA	330	300	480	290	180	14	5	立式 Vertical
JBK5-30KVA	330	320	480	290	200	14	5	立式 Vertical
JBK5-40KVA	330	320	480	290	300	14	5	立式 Vertical
JBK5-50KVA	440	320	600	380	210	14	7	立式 Vertical
JBK5-60KVA	440	320	600	380	210	14	7	立式 Vertical

* 此产品需在订货时备注卧式或立式。

*This product should be noted horizontal or vertical when ordering.

型号 Model	额定容量 Rated capacity (VA)	效率 Efficiency (%)	负载下的输出电压 Load output voltage		空载下的输出电压 Unload output voltage		额定输入 电压(V) Rated input voltage	额定输出 电压(V) Rated output voltage	备注 Remarks
			信号绕组(%) signal winding	控制绕组(%) control winding	信号绕组(%) signal winding	控制绕组(%) control winding			
JBK5-40	40	80	$6 \geq U_m > 5$ $12 \geq U_m > 10$	95%-105% UH	6或12	1.1Um	AC380 ±5%	AC220 (127) 110	控制 control
JBK5-63	63								
JBK5-100	100								
JBK5-160	160								
JBK5-250	250								
JBK5-400	400								
JBK5-630	630								
JBK5-800	800								
JBK5-1000	1000								
JBK5-1600	1600								
JBK5-2500	2500	90	$6 \geq U_m > 4.5$ $12 \geq U_m > 9$	95%-105% UH	6或12	1.1Um	AC220 ±5%	48 35 24	照明 或 控制 light or control
JBK5-3000	3000								
JBK5-4000	4000								
JBK5-5000	5000	90	$12.8 \geq U_m > 9.6$ $13.5 \geq U_m > 10$	95%-105% UH	6或12	1.1Um	AC220 ±5%	12 6	信 号 signal
JBK5-6000	6000								
JBK5-7000	7000								
JBK5-8000	8000								
JBK5-10000	10000								
JBK5-15KVA	15000								
JBK5-20KVA	20000								
JBK5-30KVA	30000								
JBK5-40KVA	40000								
JBK5-50KVA	50000								
JBK5-60KVA	60000								

成品识别码 (Product Identification Code)

JB	-	K5	-	■	/	■
变压器 transformer		控制 control		容量 (VA) Capacity (VA)		热带产品代号 Tropical product code
						湿热带TH 干热带TA Hot and humid Dry tropical TA belt TH

JBK6系列变压器

JBK6 series transformer

产品概述 (Product Introduction)

JBK6系列变压器是我公司引进国外最新型变压器系列, 在JBK5变压器的基础上, 开发出新一代变压器JBK6变压器外形、安装尺寸、使用场合与JBK5变压器等同。

Jbk6 series transformer is the latest transformer series introduced by our company from abroad. On the basis of JBK5 transformer, a new generation of transformer jbk6 transformer has been developed. Its shape, installation dimension and application occasion are the same as JBK5 transformer.

产品特点 (Product Features)

- 1、接线螺丝比JBK5大, 接线更方便, 更牢固;
- 2、在用户要求下, 可带短路与热保护装置, 使用更可靠;
- 3、变压器采用真空浸漆工艺, 绝缘材料采用国外进口材料, 绝缘性能更稳定。

1. The terminal screw is bigger than JBK5 which make it more convenient to connect.
2. It has short-circuit and heat protection and is more reliable.
3. Adopts technology of vacuum painting and imported insulation material, which make its ability more steady.

外形及安装尺寸 (Appearance and installing size)

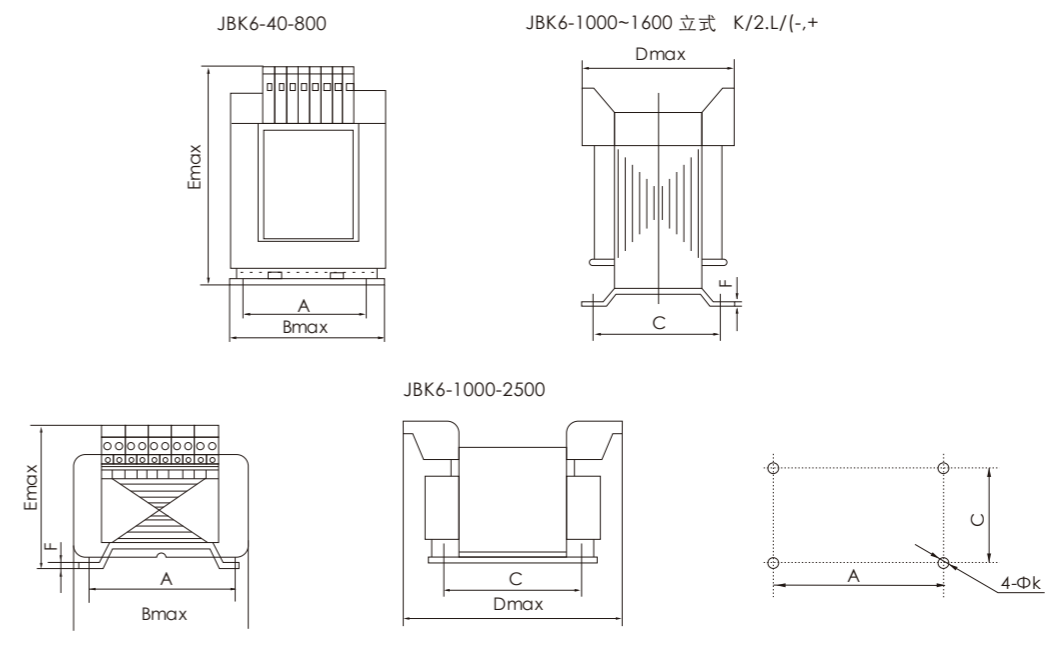

成品识别码 (Product Identification Code)

JB	-	K6	-	■	/	■
变压器 transformer		控制 control		容量 (VA) Capacity (VA)		热带产品代号 Tropical product code
						湿热带TH 干热带TA Hot and humid Dry tropical TA belt TH

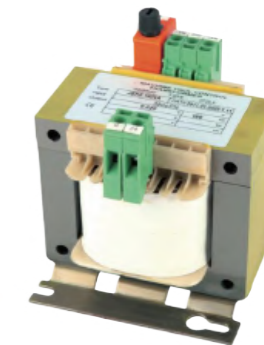

■ 技术数据 (Technical data)

型号 Model	长 B max	宽 D max	高 E max	安装孔距 Hole distance A	安装孔距 Hole distance C	安装孔距 Hole distance K	F max	备注 Remarks
JBK6-40/63	78	72	90	56±0.15	46±0.125	4.6	1.5	
JBK6-100	84	75	96	64±0.15	62±0.15	4.6	1.5	
JBK6-160	96	92	105	84±0.175	73.5±0.15	5.5	1.5	
JBK6-250	96	100	104	84±0.175	85±0.175	5.8	1.5	
JBK6-400	120	100	122	90±0.175	85±0.175	5.8	2	
JBK6-500	120	110	122	90±0.175	96±0.175	5.8	2	
JBK6-630	150	110	140	122±0.2	90±0.175	7	2	
JBK6-800	150	128	142	122±0.2	105±0.2	7	2	
JBK6-1000	150	190	142	130±0.2	152±0.2	7	3	卧式 Horizontal
JBK6-1000	168	125	155	138±0.2	105±0.2	9	2	立式 Vertical
JBK6-1600	170	225	153	148±0.2	176±0.2	7	3	卧式 Horizontal
JBK6-1600	168	138	155	138±0.2	116±0.2	7	2	立式 Vertical
JBK6-2500	194	250	170	170±0.2	200±0.23	7	4	卧式 Horizontal

* 此产品需在订货时备注卧式或立式。

*This product should be noted horizontal or vertical when ordering.

型号 Model	额定容量 (VA) Rated capacity	效率 Efficiency (%)	负载下的输出电压 Load output voltage		空载下的输出电压 Unload output voltage		额定输入 电压 (V) Rated input voltage	额定输出 电压 (V) Rated output voltage	备注 Remarks
			信号绕组 (%) signal winding	控制绕组 (%) control winding	信号绕组 (%) signal winding	控制绕组 (%) control winding			
JBK6-40	40	80	6 ≥ Um > 5 12 ≥ Um > 10	95%-105% UH	6或12	1.1Um	AC220 ±5%	AC220 (127) 110	控制 control The distribution of every winding capacity can be made according to user's demand
JBK6-63	63								
JBK6-100	100								
JBK6-160	160	85	6 ≥ Um > 5 12 ≥ Um > 10	95%-105% UH	6或12	1.1Um	AC220 ±5%	48 35 24	照明 或 控制 light or control
JBK6-250	250								
JBK6-400	400								
JBK6-630	630	90	6 ≥ Um > 4.5 12 ≥ Um > 9	95%-105% UH	6或12	1.1Um	AC220 ±5%	12 6	信号 signal
JBK6-800	800								
JBK6-1000	1000								
JBK6-1600	1600								
JBK6-2500	2500								

JBK7系列 变压器

JBK7 series transformer

■ 产品概述 (Product Introduction)

JBK7系列变压器,是我公司在JBK5变压器的基础上,开发出的一款“贵”族式变压器。JBK7的外形尺寸、安装尺寸与JBK5相同,而在选材上,更精选时下性能优异的材料,将变压器的绝缘等级提高到了F级,其空载性能,负载性能都优于JBK5系列产品,是一款当之无愧的节能环保产品。

Jbk7 series transformer is a "expensive" family transformer developed by our company on the basis of JBK5 transformer. The overall dimensions and installation dimensions of jbk7 are the same as those of JBK5. In terms of material selection, more materials with excellent current performance are selected, which improves the insulation level of transformer to level F. its no-load performance and load performance are better than those of JBK5 series products. It is a well deserved energy-saving and environmental protection product.

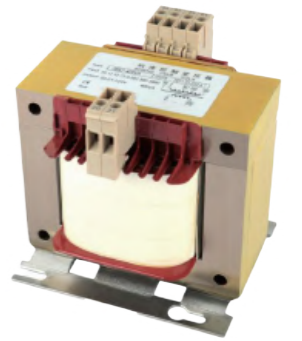

■ 产品特点 (Product Features)

- 1、接线端子增加了插拔式的快速连接功能;
- 2、在客户要求时,可带短路与热保护装置,使用更安全可靠;
- 3、采用整台浸漆工艺,绝缘等级F级,提高了产品防潮,防霉,防盐雾的能力,可使用在干热带,湿热带等恶劣环境当中。

1. The connection terminal adds plug-in quick connection function;
2. When required by customers, it can be equipped with short circuit and thermal protection devices, which is safer and more reliable;
3. The whole impregnation process is adopted, and the insulation grade is f, which improves the ability of the product to prevent moisture, mold and salt fog. It can be used in dry tropical, humid and hot zones and other harsh environments.

■ 成品识别码 (Product Identification Code)



■ 外形及安装尺寸 (Appearance and installing size)

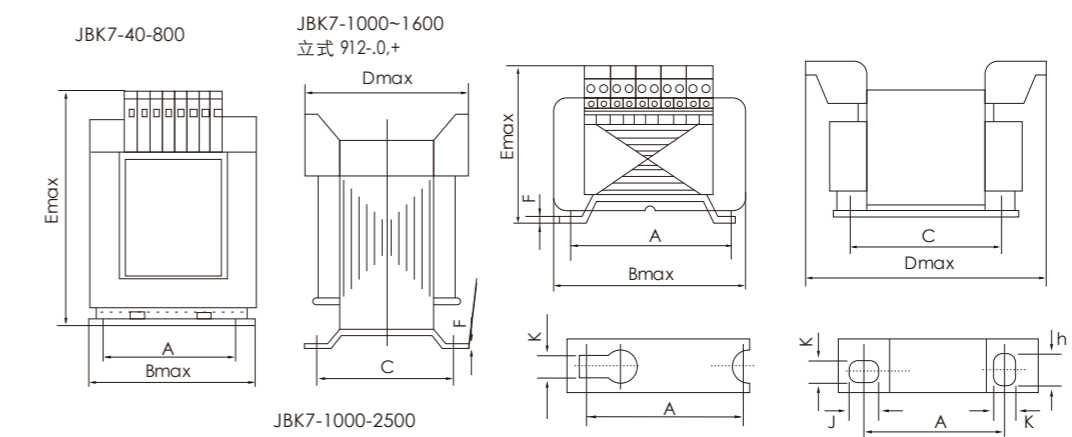

■ 技术数据 (Technical data)

型号 Model	长 B max	宽 D max	高 E max	安装孔距 Hole distance A	安装孔距 Hole distance C	安装孔距 Hole distance K	F max	备注 Remarks
JBK7-40/63	78	72	90	56±0.5	46±0.5	4.6	1.5	
JBK7-100	84	75	96	64±0.5	62±0.5	4.6	1.5	
JBK7-160	96	92	105	84±0.5	73.5±0.5	5.5	1.5	
JBK7-250	96	100	105	84±0.5	85±0.5	5.8	1.5	
JBK7-300	96	107	105	84±0.5	85±0.5	5.8	2	
JBK7-400	120	100	122	90±0.5	85±0.5	5.8	2	
JBK7-630	150	110	140	122±0.5	90±0.5	7	2	
JBK7-800	150	128	142	122±0.5	105±0.5	7	2	
JBK7-1000	150	190	142	130±0.2	152±0.2	7×12	3	卧式 Horizontal
JBK7-1000	168	138	155	138±0.5	105±0.5	9×15	2	立式 Vertical
JBK7-1600	170	225	153	144±0.2	176±0.2	7×12	3	卧式 Horizontal
JBK7-1600	168	138	155	138±0.2	116±0.2	7×15	2	立式 Vertical
JBK7-2500	194	250	170	170.5±0.2	200±0.23	7×12	4	卧式 Horizontal

* 此产品需在订货时备注卧式或立式。 *This product should be noted horizontal or vertical when ordering.

型号 Model	额定容量 (VA) Rated capacity	效率 Efficiency (%)	负载下的输出电压 Load output voltage		空载下的输出电压 Unload output voltage		额定输入 电压(V) Rated input voltage	额定输出 电压(V) Rated output voltage	备注 Remarks
			信号绕组(%) signal winding	控制绕组(%) control winding	信号绕组(%) signal winding	控制绕组(%) control winding			
JBK7-40	40	85					AC220 AC380 ±5%	控制 (127) 110 控制	各绕组容量分配可按照用户要求制造
JBK7-63	63								
JBK7-100	100								
JBK7-160	160	90	6≥Um>5 12≥Um>10	95%-105% UH	6或12	1.1Um	AC220 ±5%	照明 或 控制 light or control	The distribution of every winding capacity can be made according to user's demand
JBK7-250	250								
JBK7-400	400								
JBK7-630	630								
JBK7-800	800	94	6≥Um>4.5 12≥Um>9				AC220 ±5%	信号 12 6 signal	
JBK7-1000	1000								
JBK7-1600	1600								
JBK7-2500	2500								



单相直流变压器
Single phase DC transformer



环形变压器
Ring transformer



三相直流变压器
Three phase DC transformer



SG三相变压器
SG three phase transformer



JSG三相变压器
JSG three phase transformer



环形灌封变压器
Ring encapsulated transformer

波纹电阻器 (RXHG) Wire Wound Resistor

产品概述 (Product Introduction)

RXHG型涂漆绕线电阻器是一种功率型绕线电阻器，该产品采用波状电阻合金带以侧立形式缠绕在陶瓷骨架上，表面被覆绝缘耐高温涂料，有利于散热，并配有安装支架，电阻器具有功率大，耐过载能力强，安装方便等特点。

RXHG coatings type winding resistor is a kind of power mode, the product use the wave resistance alloy in the form of side winding on the ceramic matrix. The surface coating insulation resistance to high temperature coating, is conducive to heat dissipation, and is equipped with a mounting bracket, a resistor has large power, strong overload capacity, resistance, convenient installation and other feature.

产品应用 (Product Application)

1. 做为制动电阻保护变频器、伺服等不受电机再生电能的危害
2. 电力电子负载测试中做为阻性负载
3. 在电力电子设备中做为取样电阻、限流电阻、起动电阻、保护电阻

1. As a braking resistor to protect the inverters, servos, etc., from damage by regenerative energy of the motor;
2. As a resistive load in power electronic load tests;
3. As a sampling resistor, limiting resistor, starting resistor, or protective resistor in power electronic equipment."

技术规格 (Technical Specifications)

1. 阻值及阻值允许偏差: $1\Omega \leq R \pm 5\%$ (J), $1\Omega > R \pm 10\%$ (K)
2. 额定负荷: 表面最高温度: $50 \sim 200W \leq 275^\circ C$, $> 200W \leq 350^\circ C$
3. 短时过负荷: 无可见损伤, $\Delta R \leq \pm (5\%R + 0.05\Omega)$ 10倍 5s
4. 绝缘电阻: $R \geq 100M\Omega$ 1min DC 1000V
5. 耐电压: 无可见损伤, 无飞弧击穿 $\Delta R \leq \pm (0.1\%R + 0.05)$ AC 3000V 5S
6. 电阻温度特性: $\pm 260PPM/^\circ C$ (小于 5Ω 以不作检测)
7. 端子强度: 无松动或机械损伤 45N 30S"
8. 电阻体强度: 无可见损伤 200N 30S
9. 耐振性: 无可见损伤, $\Delta R \leq \pm (0.1\%R + 0.05\Omega)$ f: 5-200Hz a=1g X.Y.Z各2h
10. 耐热性: 除端子外无明显变色和损伤, 标志清晰 $350^\circ C$ 2hours
11. 热冲击: 无可见机械损伤 额定负载30分钟后 $-55^\circ C$ 温度下 15min
12. 耐湿性: 无可见损伤, 标志清晰, $\Delta R \leq \pm (5\%R + 0.05\Omega)$
绝缘电阻 $\geq 10M\Omega$ DC 100 40 $^\circ C$ 95%RH 500hours
13. 耐久性(额定负载): 外观无可见损伤, 标志清晰, $\Delta R \leq \pm (5\%R \pm 0.05\Omega)$ 100%负荷

1. Resistance value and the change range : $1\Omega \leq R \pm 5\%$ (J), $1\Omega > R \pm 10\%$ (K)
2. Rated load: The maximum surface temperature, $50 \sim 200W \leq 275^\circ C$, $> 200W \leq 350^\circ C$
3. Short-time overload: No visible damage $\Delta R \leq \pm (5\%R + 0.05\Omega)$ 10 times 5s
4. Insulation resistance: $R \geq 100M\Omega$ 1min DC 1000V
5. Withstanding voltage: No visible damage, no arcing breakdown $\Delta R \leq \pm (0.1\%R + 0.05)$ AC 3000V 5S
6. Resistance-temperature characteristic: $\pm 260PPM/^\circ C$ ((less than 5Ω don't test
7. Terminal strength No looseness or mechanical damage 45N 30s
8. Resistance strength No visible damage 200N 30S
9. Withstanding vibration: No visible damage $\Delta R \leq \pm (0.1\%R + 0.05\Omega)$ f: 5-200Hz a=1g X.Y.Z/2h
10. Heat resistance: In addition to the terminal no obvious discoloration and damage, marked clearly $350^\circ C$ 2hours
11. Heat shock No visible mechanical damage, after 30minute rated overload
12. Waterlogging resistance: No visible mechanical damage, marked clearly $\Delta R \leq \pm (5\%R + 0.05\Omega)$
Insulation resistance $\geq 10M\Omega$ DC 100 40 $^\circ C$ 95%RH 500hours
13. Durability (rated overload): No visible damage, marked clearly $\Delta R \leq \pm (5\%R \pm 0.05\Omega)$ load 100%
8. Withstanding vibration: No visible damage $\Delta R \leq \pm (0.1\%R + 0.05\Omega)$ f: 5-200Hz a=1g X.Y.Z/2h
9. Resistance : In addition to the terminal no obvious discoloration and damage, marked clearly.
 $350 \pm 5^\circ C$, 120 ± 5

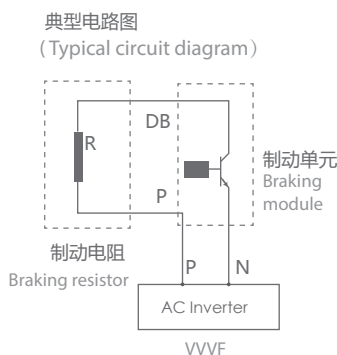
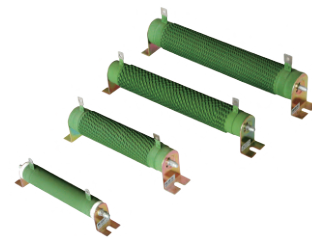

执行标准 (Applicable Standards)

GB/T5729-1994 Fixed resistor used in electronic equipment

降额曲线 (Rundown Curve)

环境温度 Ambient temperature	0-20 $^\circ C$	>20 $^\circ C$
功率损耗 Power loss	100%	See figure

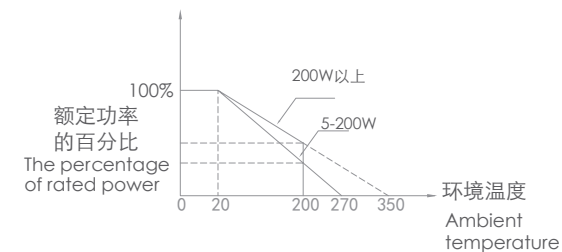

表面温升 (Surface Temperature Rise)

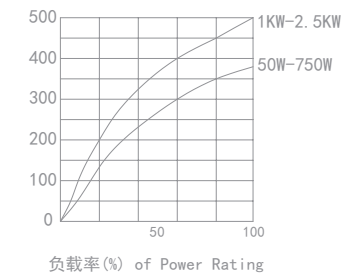

产品尺寸图 (Product Size)

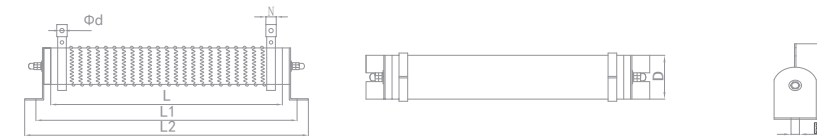

规格 Type	额定功率(W) Rated Power	尺寸 Dimension ($\pm 1mm$)							
		L	L1	L2	D	B	H	N	ϕd
RXHG	50	90	132	146	28	6.5	62	10	4.5
RXHG	60	90	132	146	28	6.5	62	10	4.5
RXHG	80	140	182	198	28	6.5	62	10	4.5
RXHG	100	170	212	198	28	6.5	62	10	4.5
RXHG	150	192	222	238	40	8	90	12	5.5
RXHG	200	192	222	238	40	8	90	12	5.5
RXHG	300	280	310	326	40	8	90	12	5.5
RXHG	400	280	310	326	40	8	90	12	5.5
RXHG	500	316	346	360	50	8	107	16	6
RXHG	600	316	346	360	50	8	107	16	6
RXHG	750	316	346	360	50	8	107	16	6
RXHG	1000	300	334	350	60	8.5	127	16	6
RXHG	1200	415	449	465	60	8.5	127	16	6
RXHG	1500	415	449	465	60	8.5	127	16	6
RXHG	2000	510	544	560	60	8.5	127	16	6
RXHG	2500	600	636	652	60	8.5	127	16	6

备注: 其他规格尺寸, 可根据用户要求制造。Remark: Dimension can be customization

成品识别码 (Product Identification Code)

RXHG	—	1500W	—	40R	—	J
波纹电阻器 Wire Wound Resistor		额定功率 Rated Power		电阻阻值 Resistance Value		阻值误差 Resistance Tolerance H= $\pm 3\%$ J= $\pm 5\%$ K= $\pm 10\%$

铝壳电阻器 (RXLG) Aluminum Enclosure Resistor

产品概述 (Product Introduction)

RXLG系列铝壳绕线电阻器采用铝合金外壳,外形美观,该电阻具有耐气候性、耐振动、安全性优于传统瓷骨架电阻器。RXLG电阻器是用一种耐高温的有机硅树脂和硅粉作基本材料封装的功率型绕线电阻。易紧密安装,易附加散热器。

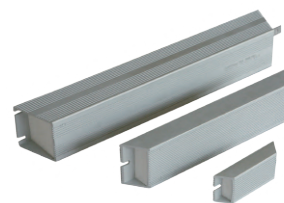

RXLG series aluminum shell winding resistor using alloy enclosure, beautiful shape, the resistance have the weather resistance, vibration resistance security is superior to the traditional porcelain skeleton resistor resistor.

产品应用 (Product Application)

1. 做为制动电阻保护变频器、伺服等不受电机再生电能的危害
2. 电力电子负载测试中做为阻性负载
3. 在电力电子设备中做为取样电阻、限流电阻、起电电阻、保护电阻

1. As a braking resistor to protect the inverters, servos, etc., from damage by regenerative energy of the motor;
2. As a resistive load in power electronic load tests;
3. As a sampling resistor, limiting resistor, starting resistor, or protective resistor in power electronic equipment.

技术规格 (Technical Specifications)

1. 电阻值以及变化范围: $1\Omega \leq R \pm 5\%$ (J), $1\Omega > R \pm 10\%$ (K)
2. 温度系数: $R > 20\Omega, \pm 260 \text{ ppm}/^\circ\text{C}$ $R \leq 20\Omega, \pm 400 \text{ ppm}/^\circ\text{C}$ 在 $-25 \sim 200^\circ\text{C}$ 温度下实验
3. 额定负荷: 表面温度 $\leq 375^\circ\text{C}$ 放在 $300 \times 300 \times 3 \text{mm}$ 铝板上
4. 短时过载: $\Delta R \leq \pm (2\%R + 0.05\Omega)$ 无异常同样环境下 10倍额定电压, 5秒
5. 绝缘电阻: $R \geq 100\text{M}\Omega$ 1min 无异常 DC 1000V, 焊片和外壳之间的绝缘电阻要求大于或等于 $100\text{M}\Omega$
6. 耐电压: $\Delta R \leq \pm (0.1\%R + 0.05\Omega)$ 无异常 无破坏焊片与外壳之间加 AC 3000V 5S
7. 端子强度: 无松动无异常 100N力加在焊片引出方向, 30秒
8. 耐振性: 无可见损伤, $\Delta R \leq \pm (0.1\%R + 0.05\Omega)$ f: 10-55Hz $a=1.5g$ X.Y.Z各2h
9. 耐热性: 除端子外无明显变色和损伤, 标志清晰加热至 $350 \pm 5^\circ\text{C}$, 120 \pm 5分钟
10. 热冲击: $\Delta R \leq \pm (2\%R + 0.05\Omega)$ 无异常 额定电压30分钟, 常温, 8-12秒放到 $-40 \pm 2^\circ\text{C}$ 环境下, 15+5分钟, 再在常温下放置2小时
11. 耐湿性: 无可见损伤, 标志清晰, $\Delta R \leq \pm (3\%R + 0.05\Omega)$, 绝缘电阻 $\geq R \geq 25\text{M}\Omega$ 直流电压 100V, $40 \pm 2^\circ\text{C}$, 相对湿度 90-95%, 60分钟开, 30分钟关, 持续500+24小时
12. 负载寿命: 外观无可见损伤, 标志清晰, $\Delta R \leq \pm (5\%R \pm 0.05\Omega)$ 放置在 $300 \times 300 \times 3$ $20 \pm 7^\circ\text{C}$, 额定直流电压, 90分钟开, 30分钟关, 循环500+24小时

1. Resistance value and the change range: $1\Omega \leq R \pm 5\%$ (J), $1\Omega > R \pm 10\%$ (K)
2. Temperature coefficient: $R > 20\Omega, \pm 260 \text{ ppm}/^\circ\text{C}$ $R \leq 20\Omega, \pm 400 \text{ ppm}/^\circ\text{C}$ Test when the temperature is $-25 \sim 200^\circ\text{C}$
3. Rated load: The surface temperature $\leq 375^\circ\text{C}$ on the $300 \times 300 \times 3 \text{mm}$ aluminum plate
4. Short-time overload: $\Delta R \leq \pm (2\%R + 0.05\Omega)$ No abnormal environment also 10 times the rated voltage, 5second
5. Insulation resistance: $R \geq 100\text{M}\Omega$ 1min Without abnormal DC 1000v, insulation resistance between welding plate and shell is no less than $100\text{M}\Omega$
6. Withstand voltage: $\Delta R \leq \pm (0.1\%R + 0.05\Omega)$ No abnormal damage welding piece between the shell and AC 3000V 5S
7. Terminal strength: Without loosening without exception 100n force on welding lead direction, 30second
10. Thermal: $\Delta R \leq \pm (2\%R + 0.05\Omega)$ No abnormal voltage rating for 30 minutes, room temperature, 8-12seconds into $-2 \sim -40$ environment, 15+5minutes, then place 2hours at room temperature
11. Wet resistance: No visible damage, marked clearly $\Delta R \leq \pm (3\%R + 0.05\Omega)$, Insulation resistance $\geq R \geq 25\text{M}\Omega$ DC voltage 100v, $40 \pm 2^\circ\text{C}$, Relative humidity 90-95%, 60minutes on 30 minutes off for 500+24
12. Overload: No visible damage, marked clearly $\Delta R \leq \pm (5\%R \pm 0.05\Omega)$ on the $300 \times 300 \times 3 \text{mm}$ aluminum plate $\pm 7^\circ\text{C}$, Rated Dc voltage, 90 minutes on 30 minutes off for 500+24 hours

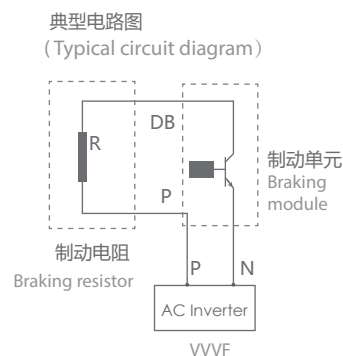

执行标准 (Applicable Standards)

GB/T5729-1994 Fixed resistor used in electronic equipment

降额曲线 (Rundown Curve)

环境温度 Ambient temperature	0-20°C	>20°C
功率损耗 Power loss	100%	See figure

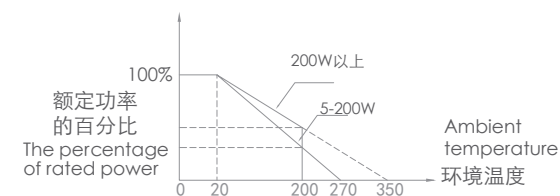

表面温升 (Surface Temperature Rise)

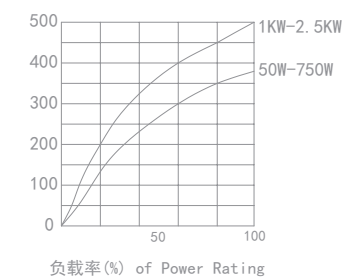

产品尺寸图 (Product Size)



规格 Type	图号 Product Picture	额定功率(W) Rated Power	尺寸Dimension (±1mm)				配线 (mm) Connecting Wire	引线长度 (mm) Lead Length	端子 Terminal
			A	B	C	D			
RXLG		60	115	102	40	20	1.5	250	2-5S
RXLG		80	140	127	40	20	1.5	250	2-5S
RXLG		100	165	152	40	20	1.5	250	2-5S
RXLG		120	190	177	40	20	1.5	250	2-5S
RXLG	图 A Picture A	150	215	202	40	20	2.5	250	2-5S
RXLG		200	165	152	60	30	2.5	250	2-5S
RXLG		300	215	202	60	30	2.5	250	2-5S
RXLG		400	265	252	60	30	2.5	250	2-5S
RXLG		500	335	322	60	30	2.5	250	2-5S
RXLG		800	400	41*387	61	59			M6
RXLG	图 B Picture B	1000	400	30*387	50	107			M6
RXLG		1200	450	30*437	50	107			M6
RXLG		1500	485	30*472	50	107			M6
RXLG		2000	550	30*537	50	107			M6
RXLG		2500	550	30*537	50	107			M6

备注: 其他规格尺寸, 可根据用户要求制造。Remark: Dimension can be customization

成品识别码 (Product Identification Code)



波纹电阻箱/柜

Resistor Assemblies/High Power Resistor Assemblies

产品概述 (Product Introduction)

Resistor assemblies was made by general resistor and settled in cabinet,

BRU (Power range):0.5KW-12.5KW

HRU (Power range): 20KW-200KW

产品尺寸图 (Product Size)

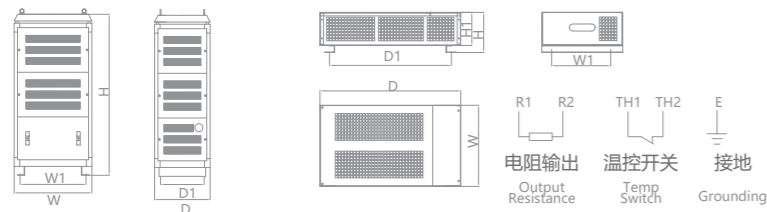

规格 Type	功率(KW) Power	尺寸Dimension (±1mm)					端子台螺钉 Terminal	重量(Kg) Weight	配线(mm) Cable	组合Combination
		W	D	H	W1	D1				
BRU	1	242	500	140	150	470	M6	5.3	6	1KW*1
	2	242	500	140	150	470	M6	6.5	6	1KW*2
	3	242	500	140	150	470	M6	7.8	6	1.5KW*2
	4.5	345	600	170	325	530	M6	12	10	1.5KW*3
	6	345	600	170	325	530	M6	14	10	1.5KW*4
	8	415	690	170	395	665	M6	16.5	10	2KW*4
HRU	10	415	690	170	395	665	M6	18.5	16	2KW*5
	12.5	415	690	170	395	665	M6	20	16	2.5KW*5
	20	700	500	845	340	620	M6	50	16	2.5KW*8
	40	700	500	1245	340	620	M6	86	25	2.5KW*16
	50	700	500	1445	340	620	M7	100	25	2.5KW*20
	60	700	500	1645	340	620	M8	115	35	2.5KW*24
	80	700	500	2045	340	620	M8	140	50	2.5KW*32
	100	700	700	2045	540	620	M8	165	50	2.5KW*40
	120	700	800	1945	640	620	M8	190	75	2.5KW*48

供选配件: 散热轴流风机, 户外防雨百叶窗盖板, 底部轮子。

For Options: cooling axial fan, Outdoor rain shutters cover, The bottom of the wheel.

备注: 其他规格尺寸, 可根据用户要求制造。

Remark: Dimension can be customization

成品识别码 (Product Identification Code)

BRU	6KW	20R	J
BRU: Resistor Assemblies	额定功率 Rated Power	电阻阻值 Resistance Value	阻值误差 Resistance Tolerance H=±3% J=±5% K=±10%
HRU: High Power Resistor Assemblies			

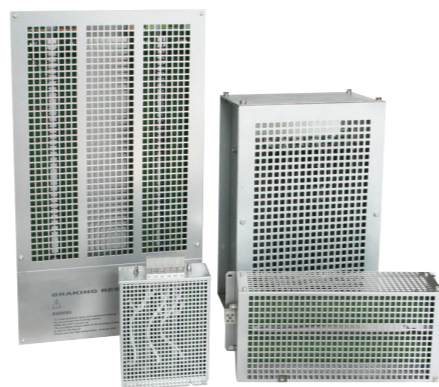

铝壳电阻箱 (LRA)

Aluminum Enclosure Resistor Assemblies

产品概述 (Product Introduction)

LRA系列铝壳电阻箱是由铝壳电阻器组合而成的

Resistor assemblies was made by Aluminum Enclosure resistor and settled in cabinet,

功率范围(Power range): 0.5KW-12.5KW

产品尺寸图 (Product Size)

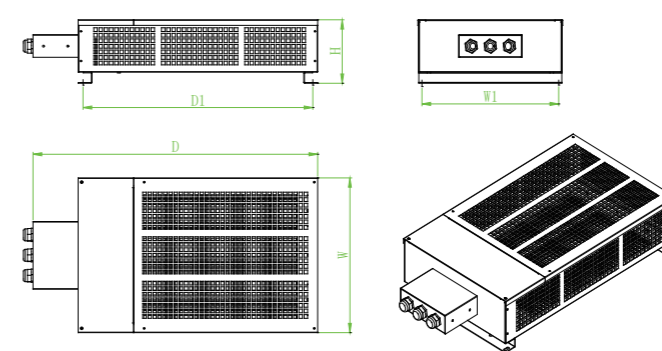

规格 Type	功率(KW) Power	尺寸Dimension (±1mm)					端子台螺钉 Terminal	配线(mm) Cable	组合Combination
		W	D	H	W1	D1			
LRA	1	242	500	140	150	470	M6	6	1KW*1
LRA	2	242	500	140	150	470	M6	6	1KW*2
LRA	3	242	500	140	150	470	M6	6	1.5KW*2
LRA	4.5	345	600	170	325	530	M6	10	1.5KW*3
LRA	6	345	600	170	325	530	M6	10	1.5KW*4
LRA	8	415	690	170	395	665	M6	10	2KW*4
LRA	10	415	690	170	395	665	M6	16	2KW*5
LRA	12.5	415	690	170	395	665	M6	16	2.5KW*5

备注: 其他规格尺寸, 可根据用户要求制造。

Remark: Dimension can be customization

成品识别码 (Product Identification Code)

LRA	6KW	20R	J
铝壳电阻箱 Aluminum Enclosure Resistor Assemblies	额定功率 Rated Power	电阻阻值 Resistance Value	阻值误差 Resistance Tolerance H=±3% J=±5% K=±10%



典型电路图 (Typical circuit diagram)

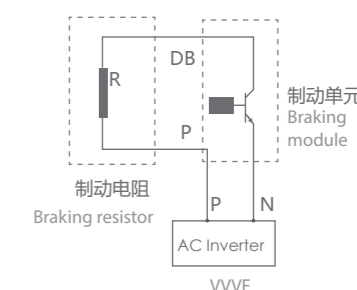

加热管电阻箱 (JRA) Heating pipe Resistor Assemblies

产品概述 (Product Introduction)

JRA 加热管电阻箱的绕线电阻器采用不锈钢管外包, 外形美观, 该电阻具有耐气候性、耐振动、散热快, 防护等级高等特点, 安全性优于传统瓷骨架电阻器。该电阻器是用一种耐高温的有机硅树脂和硅粉作基本材料封装的功率型绕线电阻。易紧密安装, 易附加散热器。做为制动电阻保护变频器、伺服等不受电机再生电能的危害, 电力电子负载测试中做为阻性负载。

The wire-wound resistor of the resistance box of the JRA heating pipe adopts stainless steel pipe as the wrap which has a good looking appearance. The resistor has the characteristics of weather resistance, vibration resistance, fast heat dissipation, high level of protection, etc. Its security is superior to traditional resistors of porcelain skeleton. The resistor is a power type wirewound resistor packaged with the basic materials of high temperature-resistant silicone resin and silica fume. Easy to install tightly and easy to attach heat sink. Usable as a braking resistor to protect the inverters, servos, etc., from damage by regenerative energy of the motor, and as a resistive load in power electronic load tests.

功率范围(RA Power range):1KW-12KW

产品尺寸图 (Product Size)

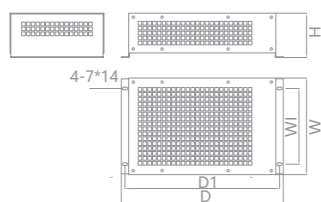

规格 Type	功率(KW) Power	尺寸Dimension (±1mm)					安装孔 Mounting holes
		D	D1	W	W1	H	
JRA	1	575	555	255	200	117	7*14
JRA	2	575	555	255	200	170	7*14
JRA	3	575	555	255	200	170	7*14
JRA	4	575	555	255	200	170	7*14
JRA	6	575	555	255	200	170	7*14
JRA	8	575	555	255	200	260	7*14
JRA	10	575	555	255	200	260	7*14
JRA	12	575	555	255	200	260	7*14

备注: 其他规格尺寸, 可根据用户要求制造。
Remark: Dimension can be customization

成品识别码 (Product Identification Code)

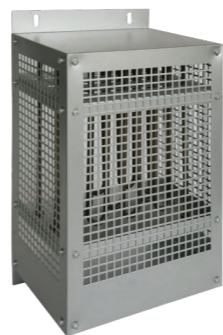
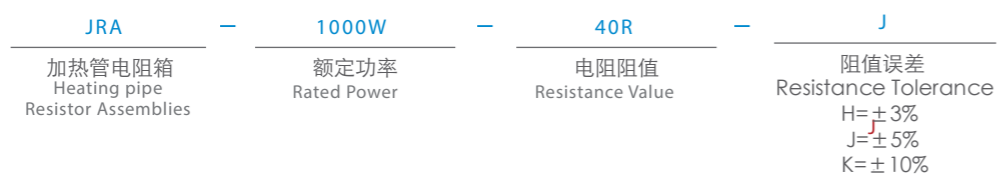

不锈钢电阻柜 (SRA) SUS Resistor Assemblies

产品概述 (Product Introduction)

可用在变频器控制电机减速和制动的电路中, 通常外接电阻器可以将来自电动机和负载的多余能量消耗掉, 以保护变频器的过压保护。在工业系统中, 变频器制动电阻被广泛应用于电机启动制动调速、变频器制动、起吊行业大型机械制动、物料输送机构制动等领域。它们可以短时断续周期和持续的工作。

usable in a circuit of inverter to control the motor deceleration and braking. Usually an external resistor can consume the excess energy from the motor and load to protect the overvoltage crowbar of the inverter. In industrial systems, the inverter braking resistors are widely used in the fields of motor starting, braking and speed regulating, inverter braking, braking of large lifting machinery, braking of material handling mechanisms, etc. They can run both in short-term intermittent cycles and continuous cycles.

电流范围 Current Range: 10-1000A
电压范围 Voltage Range: 220-1140V

执行标准 (Applicable Standards)

GB/T5729-1994Fixed resistor used in electronic equipment

产品尺寸图 (Product Size)

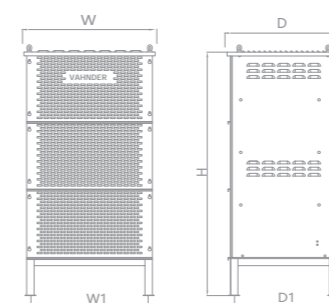

规格 Type	功率(KW) Power	尺寸Dimension (±1mm)				
		L	W	H	W1	D1
SRA	20KW	760	560	842	644	400
SRA	30KW	760	560	1140	644	400
SRA	40KW	760	560	1440	644	400
SRA	50KW	760	560	1740	644	400
SRA	51-80KW	880	760	1580	764	600
SRA	81-100KW	880	760	1930	764	600

备注: 其他规格尺寸, 可根据用户要求制造。
Remark: Dimension can be customization

成品识别码 (Product Identification Code)



中性点接地电阻 (NRA)

Neutral Grounding Resistor

产品概述 (Product Introduction)

中性点接地电阻器连接于发电机、变压器的中性点与大地之间的一种限流电气保护设备，当电网线路出现故障时，电源中性点电压将产生偏移，尤其是在电缆供电的电网系统中，对地电容电流较大，当该电流大于规定值时会产生弧光接地过电压，从而使非故障相的对地电压极大地增加，使设备绝缘损坏形成两点或多点接地短路造成停电事故。采用中性点电阻接地方式的目的是给故障点注入阻性电流，使接地故障电流呈阻容性质，减小与电压的相位差，降低故障点电流过零熄弧后的重燃率，使过电压限制在一定水平以内，提高继电保护设备灵敏度以实现跳闸、快速寻找故障线路和备用切换，从而有效保护系统正常运行。

The neutral grounding resistor is a current limiting electrical protection device connected between the neutral points of the generator and transformer. In case of failure in the power network, the neutral voltage will produce an offset, especially in a grid system of cables whose capacitive earth current is high, arc grounding overvoltage will be produced when the current is greater than the specified value so that the non-fault phase-to-ground voltage will be greatly increased, the equipment insulation will be damaged, thus causing short circuit of earthing at two or more points and power outage.

产品应用 (Product Application)

装置可适用于0.4~110kV电压等级配电网的中性点接地系统，在电力系统的变电所或发电厂也已经得到了广泛的应用，对提高系统供电可靠性及安全运行有明显的效果。

The device is suitable for use in the dead earthed neutral system of a distribution network of 0.4-110kV voltage level.

执行标准 (Applicable Standards)

GB/T5729-1994 Fixed resistor used in electronic equipment

产品尺寸图 (Product Size)

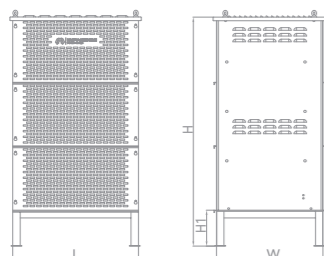

规格 Type	电压 (KV) Voltage	电流 Current	阻值范围R(20°C) Resistance Range	尺寸Dimension (±1mm)		
				L	W	H
NRA	6.3	50-1000A	50-1000A	850	1000	1500
NRA	10.5	50-2000A	50-2000A	1000	1000	2000
NRA	20	50-2000A	50-2000A	1500	2000	2200
NRA	35	50-2000A	50-2000A	1600	2500	2500

备注：其他规格尺寸，可根据用户要求制造。 Remark: Dimension can be customization

成品识别码 (Product Identification Code)

NRA	-	6.3KV	-	100A	-	100R
中性点接地电阻 Neutral Grounding Resistor		电压 Voltage		电流 Current		阻值 Resistance

Crowbar/Chopper Resistor

This crowbar resistor is mainly applied in the technology of low voltage ride through in the wind power generation inverter. Installed at the side of the wind power generator rotor, it works as a current transformer at the bypass rotor side. While low-voltage disturbance occurs in the power grid, it can prevent the over-high voltage of the DC bus and the ultra strong rotor current. It is mainly used for the fault state and damped stator flux linkage. The crowbar resistor can dissipate huge amount of energy instantaneously.



Life Evaluation of Crowbar Resistors

Take 1.5MW windmill generator for example, environmental temperature <math>< 60^{\circ}\text{C}</math>

200J	1 time/second	
220KJ	1 time/half an hour	350000 times(20 years of life)
640KJ	1 time/week	1000 times(20 years of life)
1360KJ	1 time/month	250 times(20 years of life)

Low Voltage Ride Through Wind Turbine

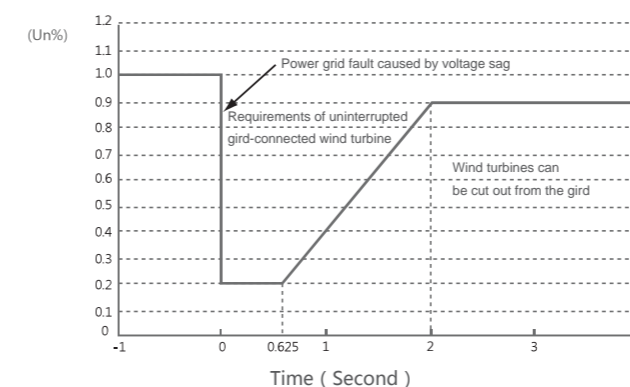

Operating Condition Comparison

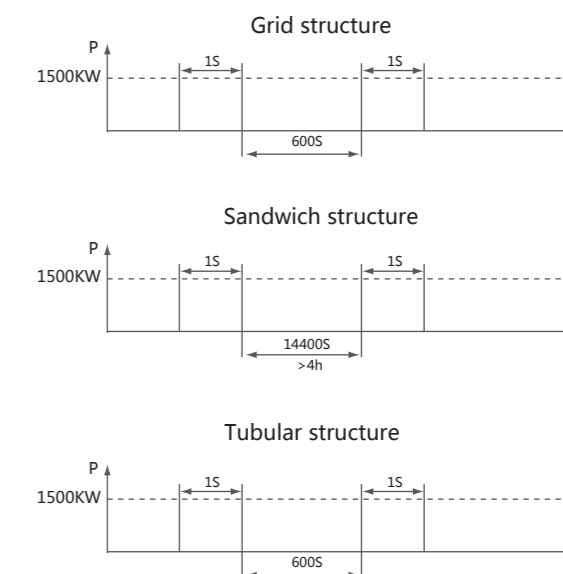

Framework Comparison

Type	Weight (kg)	Size (mm)	Temperature rise (°C)	Cost
Grid structure	26	500x450x150	450	Middle
Sandwich structure	28	491x320x200	200	Low
Tubular structure	45	300x200x120	400	High

Comparison of the Resistor Materials

Material	Density g/mm ³	Resistivity Ω·mm /m ³	Heat capacity J/g·K	Thermal Conductivity w/m·°C	Temperature feature ppm/°C
SUS304	0.008	0.72	0.50	13.2	< 1400
SUS316	0.008	0.78	0.45	13.23	< 900
Cr20Ni80	0.008	0.84	0.46	13.2	< 600
Cr20Ni80	0.0084	1.09	0.441	16.0	< 100

RHP150-B 型功率型厚膜电阻器

RHP150-B power type thick film resistor

产品特点 (Product Feature)

- 0.5%精度
- 大功率
- 无感设计
- 阻值范围宽
- 安装方便
- 同一封装可有 3 个不同阻值电阻
- 四个引出端子
- 0.5% Tolerance available
- High power rating
- Non inductive
- Wide ohmic value range
- Easy mounting
- 3 Different resistors in 1 module available
- 4 Terminals available

产品尺寸图 (Product Size)

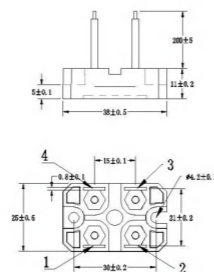

技术参数 (SPECIAL FEATURES)

型号 TYPE	RHP150-B		
阻值范围 Resistance value range	0.1Ω~1Ω	1Ω~10Ω	10Ω~1MΩ
精度 Tolerance	±5%;±10%	±5%;±10%	±1%;±5%
温度系数 TCR	±500ppm/°C	±250ppm/°C	±50ppm/°C; ±100ppm/°C
最大工作电压 Max. working voltage	1500V		
绝缘层耐压 Dielectric strength	5000VDC		
温度范围 Temperature range	-55°C~155°C		
局部放电 Partial Discharg	2KVAC < 10pc		

特征参数 (PERFORMANCE)

试验项目 TEST ITEM	性能要求 SPECIFICATIONS	试验方法 TEST METHOD GB/T5729-03 IEC115-1
短时间过负荷 Short time overload	1.5 倍额定功率, 10 秒 1.5 times rated power 10s $\Delta R \leq \pm (0.25\%R + 0.05\Omega)$	4.13
快速温度变化 Rapid temperature change	$\Delta R \leq \pm (0.25\%R + 0.05\Omega)$	4.19
寿命 Load life	$\Delta R \leq \pm (1\%R + 0.05\Omega)$	4.25.2
稳态湿热 Humidity (steady states)	$\Delta R \leq \pm (1\%R + 0.05\Omega)$	4.24
气候顺序 Temperature cycling	$\Delta R \leq \pm (1\%R + 0.05\Omega)$	4.23

更高参数可协商供货。
所示功率需加装散热器，在无散热器的情况下功率为 3.5W。

Special specifications can be supplied in consultation with customers.
The condition of the above power is needed to mount a heatsink if they has no heatsinks, the power only be 3.5W

降功耗曲线 (POWER DERATING CURVE)

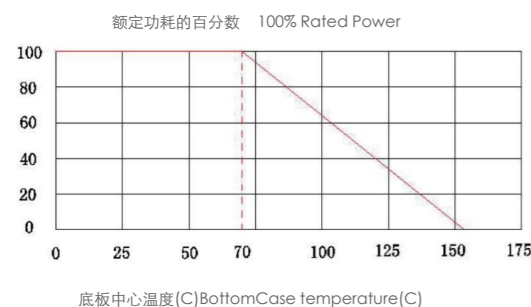

说明：当温度≤70℃时，可以满功率使用，当温度>70℃时，如曲线图所示，可以达到的功率逐渐变小，当温度在 155℃时，功率为 0。为提高导热率，电阻与散热器表面应涂抹导热硅脂，基板使用 M4 螺丝最大扭矩 1.3Nm，RHP150 引出端使用 M4 螺丝最大扭矩 1Nm。

Note: when the temperature is ≤ 70 °C, it can be used at full power. When the temperature is >70 °C, as shown in the curve, the power that can be achieved gradually decreases. When the temperature is 155 °C, the power is 0. In order to improve the thermal conductivity, the surface of the resistance and radiator should be coated with thermal conductive silicone grease. The maximum torque of M4 screw for the base plate is 1.3nm, and the maximum torque of M4 screw for rhp150 outlet is 1nm.

成品识别码 (Product Identification Code)

RHP	-	150W	-	10R	-	J
厚膜电阻器 Thick film resistor		额定功率 Rated Power		电阻阻值 Resistance Value		阻值误差 Resistance Tolerance H=±3% J=±5% K=±10%

内部电路图 (ELECTRICAL DIAGRAM)

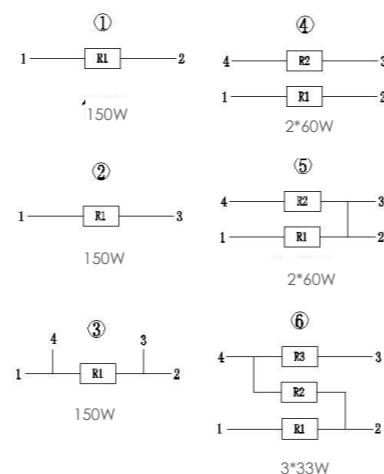

RHP250 型功率型厚膜电阻器

HIGH POWER THICK FILM RESISTORS

产品特点 (Product Feature)

- 无感设计,阻值范围宽
- 大功率
- 耐高压 6KV
- 引出端安装 M4 螺钉最大扭矩: 2Nm
- 散热片安装 M6 螺钉最大扭矩: 3Nm
- 电感<80nH
- Non-inductive,wide resistance range
- High power
- High voltage withstanding 6KV
- Contact terminal :M4 screw,Max.torque 2Nm
- Resistor inatallation :M6 screw,Max.torque 3Nm
- Inductance<80nH

产品尺寸图 (Product Size)

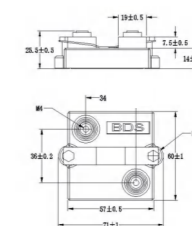

应用领域 (Apply Field)

- 电源控制设备
- 马达控制
- 变频驱动, 变频
- 机器人系统
- Voltage power supply control equipment
- Motor controlling
- Shift drive,Frequency Converter
- Robot system

特征参数 (PERFORMANCE)

试验项目 TEST ITEM	性能要求 SPECIFICATIONS	试验方法 TEST METHOD GB/T5729-03 IEC115-1
短时间过载 Short time overload	1.5 倍额定功率, 10 秒 1.5 times rated power 10s $\Delta R \leq \pm (0.5\%R + 0.05\Omega)$	4.13
快速温度变化 Rapid temperature change	$\Delta R \leq \pm (0.5\%R + 0.05\Omega)$	4.19
气候顺序 Temperature cycling	$\Delta R \leq \pm (1\%R + 0.05\Omega)$	4.23
稳态湿热 Humidity (steady states)	$\Delta R \leq \pm (0.5\%R + 0.05\Omega)$	4.24
寿命 Load life	$\Delta R \leq \pm (1\%R + 0.05\Omega)$	4.25.2

降功耗曲线 (POWER DERATING CURVE)

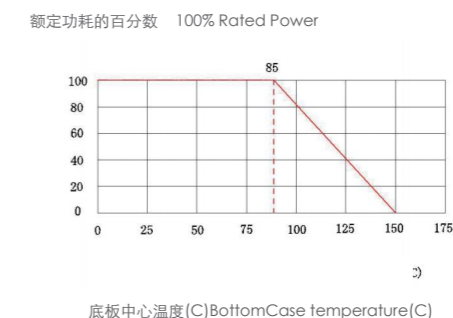

技术参数 (SPECIAL FEATURES)

型号 Model	85℃额定功率 Power Rating at 85°C	阻值范围 Resistance Range(Ω)	电阻温度系数 TCR (ppm/°C)	阻值精度 Resistance Tolerance(%)	最大工作电压 Max.work Voltage(V)	工作温度 Work Temperature
RHP	250W	R<1Ω	±500	±10%	5KV	-55°C~+155°C
		1Ω<R<10	±300	±5%		
		R>10Ω	±150	±5%		

成品识别码 (Product Identification Code)

RHP	-	250W	-	10R	-	J
厚膜电阻器 Thick film resistor		额定功率 Rated Power		电阻阻值 Resistance Value		阻值误差 Resistance Tolerance H=±3% J=±5% K=±10%



RHP600 型功率型厚膜电阻器

RHP600 power type thick film resistor

产品特点 (Product Feature)

- 无感设计,阻值范围宽 · Non-inductive,winde resistance range
- 大功率 · High power
- 耐高压 6KV · High voltage withstanding 6KV
- 引出端安装 M4 螺钉最大扭矩: 2Nm · Contact terminal :M4 screw,Max.torque 2Nm
- 散热片安装 M4 螺钉最大扭矩: 2Nm · Resistor inatallation :M4 screw,Max.torque 2Nm
- 电感<80nH · Inductance<80nH

产品尺寸图 (Product Size)

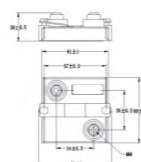

特征参数 (PERFORMANCE)

试验项目 TEST ITEM	性能要求 SPECIFICATIONS	试验方法 TEST METHOD GB/T5729-03 IEC115-1
短时间过载 Short time overload	1.5 倍额定功率, 10 秒 1.5 times rated power 10s $\Delta R \leq \pm (0.5\%R + 0.05\Omega)$	4.13
快速温度变化 Rapid temper ature change	$\Delta R \leq \pm (0.5\%R + 0.05\Omega)$	4.19
气候顺序 Temperature cycling	$\Delta R \leq \pm (1\%R + 0.05\Omega)$	4.23
稳态湿热 Humidity (steady states)	$\Delta R \leq \pm (0.5\%R + 0.05\Omega)$	4.24
寿命 Load life	$\Delta R \leq \pm (1\%R + 0.05\Omega)$	4.25.2

降功耗曲线 (POWER DERATING CURVE)

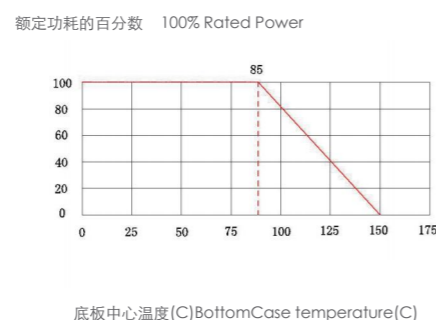

技术参数 (SPECIAL FEATURES)

型号 Model	85°C额定功率 Power Rating at 85°C	阻值范围 Resistance Range(Ω)	电阻温度系数 TCR (ppm/°C)	阻值精度 Resistance Tolerance(%)	最大工作电压 Max.work Voltage(V)	工作温度 Work Temperature	工作温度 Work Temperature
RHP	600W	1Ω<R≤10 R>10Ω	±300 ±150	±5% ±5%	5KV	-55°C~+155°C	4000VDC<10pc

成品识别码 (Product Identification Code)

RHP	600W	10R	J
厚膜电阻器 Thick film resistor	额定功率 Rated Power	电阻阻值 Resistance Value	阻值误差 Resistance Tolerance H=±3% J=±5% K=±10%

RTH系列不锈钢厚膜电阻器

stainless steel thick film resistor

产品概述 (Product Introduction)

RTH系列不锈钢厚膜电阻器, 具有高功率承受能力和较高的电阻值。它在电路中具有广泛的应用, 常用于电阻匹配、电流测量、温度测量等。在实际应用中, 如果能正确选用和合理使用厚膜电阻器, 可以有效提高电路的性能和稳定性。

Rth series stainless steel thick film resistor has high power bearing capacity and high resistance value. It has a wide range of applications in the circuit, commonly used in resistance matching, current measurement, temperature measurement and so on. In practical application, if the thick film resistor can be correctly selected and reasonably used, the performance and stability of the circuit can be effectively improved.

技术参数 (SPECIAL FEATURES)

RTH 系列	阻值范围 Resistance range	精度	功率 (0.53°C/W散热器)	功率 W(0.53°C/W散热器+5m/s 风冷)	脉冲功率	耐电压
RTH160			RTH160	RTH160	RTH160	RTH160
RTH180			RTH180	RTH180	RTH180	RTH180
RTH200			RTH200	RTH200	RTH200	RTH200
RTH260	10R~200R	10%	RTH260	RTH260	RTH260	2500VDC
RTH270			RTH270	RTH270	RTH270	RTH270
RTH280			RTH280	RTH280	RTH280	RTH280



产品尺寸图 (Product Size)

RTH 系列	L±0.1	D±0.1	T±0.1	øD
RTH160	31.9	28.1	0.9	2.2
RTH180	49.3	35.9	0.9	3.2
RTH200	61	40.6	0.9	5.3
RTH260	101.6	70	0.9	5.3
RTH270	122	70	1.5	5.3
RTH280	RTH280	RTH280	RTH280	RTH280

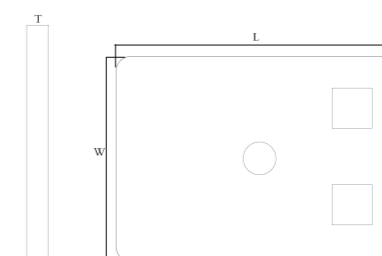

降功耗曲线 (POWER DERATING CURVE)

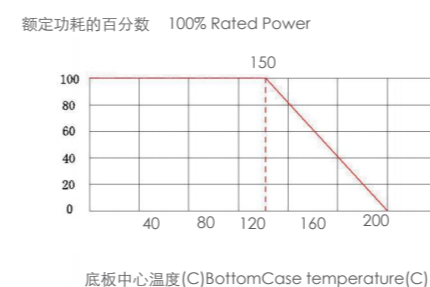

说明:当温度≤150°C时, 可以满功率使用, 当温度>150°C时, 如曲线图所示, 可以达到的功率逐渐减小, 当温度在 200°C时, 功率为0。为提高导热率, 电阻与散热器表面应涂导热硅脂, 基板使用M3 螺丝最大扭矩 2.5Nm。

Note: when the temperature is ≤ 150 °C, it can be used at full power. When the temperature is >150 °C, as shown in the curve, the power that can be achieved gradually decreases. When the temperature is 200 °C, the power is 0. In order to improve the thermal conductivity, the surface of the resistance and radiator should be coated with thermal conductive silicone grease, and the maximum torque of M3 screw for the substrate is 2.5nm.

成品识别码 (Product Identification Code)

RTH	160W	10R	J
厚膜电阻器 Thick film resistor	额定功率 Rated Power	电阻阻值 Resistance Value	阻值误差 Resistance Tolerance H=±3% J=±5% K=±10%

执行标准 (Applicable Standards)

- 1.GB/T 5729-2003
- 2.GB 5732-85
- 3.GB/T 2828.1-2003

制动单元 DBU DC Braking Module

产品概述 (Product Introduction)

采用在变频器直流侧设置制动单元组件，将再生电能消耗在功率电阻上来实现制动。通过专门的能耗制动控制电路将再生能量消耗在电阻上，转化为热能。

The function of the braking unit is to divert into a brake resistor the regenerative energy produced in the process of decelerating the motor, converting that energy into heat. Regenerative energy flows from the motor into the inverter DC bus, manifested as increased bus voltage.

产品应用 (Product Application)

主要用在变频器拖动系统需要急剧减速，刹车，定位等场合。变频器在减速时，由于拖动系统的惯性较大，此时电动机处于发电状态，机械能快速回馈到直流母线上，使直流母线电压迅速上升，从而危及变频器的安全，因此必须将该回馈能量迅速消耗掉，保持直流母线电压在某一安全范围以下，否则变频器将会过压保护或故障。一般惯性较大，或需急剧减速，刹车的场合可使用本制动单元。电梯，起重机，拉丝机，港口机械等均可使用。

The equipments make EMI or equipments sensitive to EMI. The equipments impulse circuit or .SCR Silicon Controlled Rectifier equipments. Variable equipments, Variable speed , va equipments, motor equipments

产品尺寸图 (Product Size)

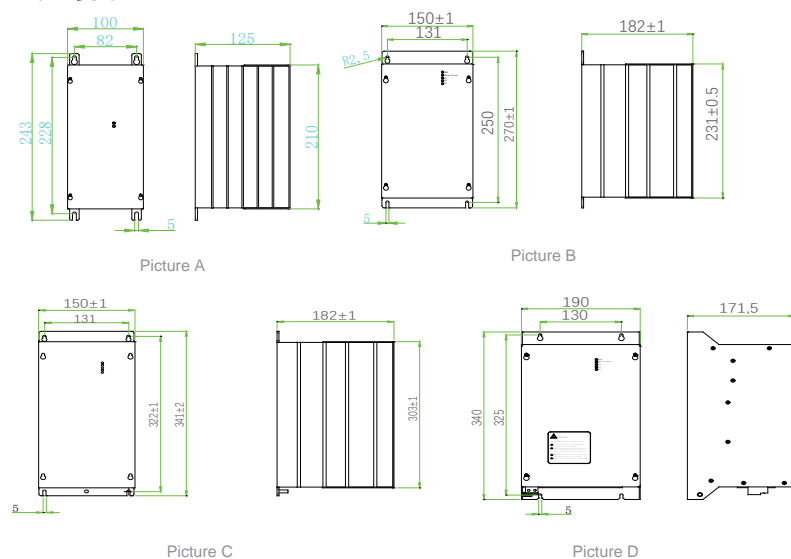

电压等级 Voltage	规格型号 TYPE	图号 Product Picture	峰值电流(A) Peak current	额定电流(A) Rated Current	最小阻值 Ω Minimum resistance
AC200V~AC300V	DBU-2015D	Picture A	50	15	10
	DBU-2030D		90	30	6.5
	DBU-4030D		50	15	20
	DBU-4045D		75	25	13.6
AC380V~AC460V	DBU-4055	Picture A	90	30	12
	DBU-4075		110	35	10
	DBU-4090	Picture B	130	45	7.5
	DBU-4110		150	50	6.5
	DBU-4160	Picture C	200	70	4.5
	DBU-4220		300	85	3
AC690	DBU-4300	Picture D	500	120	2.5
	DBU-6110		150	50	8.5
	DBU-6220		180	75	7.5
	DBU-6300		200	85	6.5

成品识别码 (Product Identification Code)

DBU	—	4030
制动单元 DC Braking Module		4: Rated Voltage 2:220V 4:380V 6:690V 11:1140V 030: Power 030=30KW

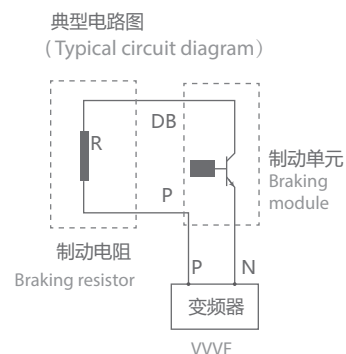

Regenerative Unit

产品概述 (Product Introduction)

The AFE regenerative unit is a compact, total all-in-one solution for low harmonics and/or full regeneration, and is the ultimate choice for power quality and energy savings. It has easy to setup and install, safe to use, parallel usage of multiple units, realize complete current sharing. It is mainly applied in cases where rapid DEC, positioning and brake is needed eg mine hoist, elevator, textile machine, paper-making machinery, centrifugal machine, drawbench, proportional action and crown block.



技术规格 (Technical Specifications)

功率范围 Power Range:	5.5-45KW
输入电压 Input Voltage	380V ± 15%, 3 PH
输出电压 Output Voltage	580-780Vdc
Carrier frequency	10 kHz
Controllable rectifier power factor	> ±0.98 (under rated load, the mains voltage harmonics <3%)
Controllable rectifier power current	<5% (under rated load, the grid voltage harmonics <3%)
Work efficiency	> 97 %
Overload capacity	120% rated current overload for 30 minutes 150% rated current overload for 1 minute
Feedback power view	The feedback power (active power) is represented by a negative number and the accuracy error < 5% at rated power.
Rectification/Feedback Distinction	Distinguish between rectifier current and feedback current: the rectification direction is positive, and the feedback direction is negative.
Measurement of feedback power	For example, it can be set to record and check the amount of energy returned within a certain hour, with an accuracy within ± 10%
Digital input	Route 1 (x1-COM)
Digital output	1 way relay (RA-RC)

产品尺寸图 (Product Size)

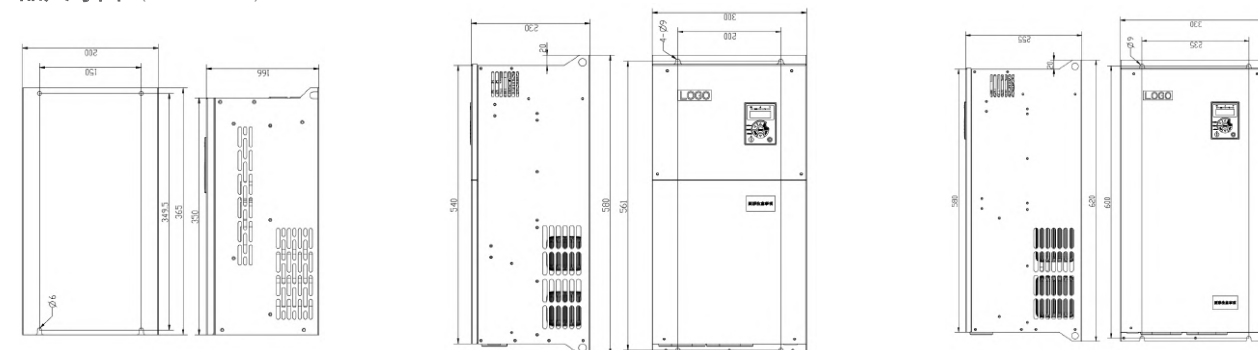

Control panel



Button Name	Name	Function Description
PRG	Programming key	Enter or exit via the first-level menu
ENTER	Confirm button	Enter the menu screen step by step, set the parameters and confirm.
▲	UP increment key	Increment of data or function code
▼	DOWN decrement key	Decreasing of data or function code
▶	shift key	In the shutdown and operation display interfaces, the displayed parameters can be cycled through; when modifying parameters, the modification digits can be selected.
🟢	Run key	In keyboard operation mode, it is used to perform operations.
🟡	Stop/Reset button	When in operation, pressing this key can be used to stop operation, subject to function code P7.02; when in fault alarm state, this key can be used to reset the fault, not subject to function code P7.02.
JOG	Shortcut multi-function key	The function of this key is determined by function code P7.01.
M	Spare key	

负载箱 (TRA) Load Bank

产品概述 (Product Introduction)

干式负载箱是我公司自主研发的电能负荷测试装置，操作容易，体积小，运输方便。可视负荷容量大小，并联电阻堆的电路增减负荷容量。调节负荷容量有手动型和电脑控制型。与传统水负荷和电阻片负载箱相比，无漏电，不产生有害气体和废水，负荷测试精度高，调节更容易，无需测试准备时间，可连续长期使用等诸多优越性。本公司定型生产的三相交流干式负载箱有高压10KV、6.6KV、3.3KV和低压690V、400V、200V及DC12V、36V、48V等电压等级。功率因数从0-1.0可调，低压三相交流400V负载箱可测三相400V和三相200V。单相220V和110V四个电压等级。高压负载箱为高压直接测试无需降压测试（不需变压器）所以体积更小，测量更为方便、更准确。

The dry-type load bank is the electrical energy load testing equipment which our company self research and develop: operate easily, small volume, convenient transportation, visible loading capacity, regulating the capacity according to the shunt resistance pile electric circuit. The adjustment of the loading capacity has manual control and computer control. Compared with the traditional water load and resistance load bank, it doesn't have the leakage, don't product the noxious gas and the waste water. The load test precision is high, the adjustment is easier, don't need to test the setup time, can continuously the long-time use and so on many superiorities. Our company lot product the three-phase AC dry-type load bank which has voltage classes: high voltage 10KV, 6.6KV, 3.3KV and low voltage 690V, 400V, 200V and DC12V, 36V, 48V and so on. Power factor can regulate from 0-1.0, low voltage three-phase AC 400V load bank can test three-phase 400V and three-phase 200V, single-phase 220V and 110V voltage classes. The high-voltage load bank doesn't need test for the high-voltage directly test (not to need transformer), therefore the volume is smaller, the survey is more convenient and more accurate

高性能，高品质 High performance, High quality

采用我公司自主研发定型的温度系数低，低阻抗的电阻管。电阻管采用了不锈钢管和不锈钢散热片，管内充满（MGO）材料，密封了钢管两头，防止湿气进入腐蚀电热元件品质。因而可以长期保持高品质的质量。采用了强制空气对流方法来冷却电阻管，使电阻管可连续工作。

We select our company self research and develop low temperature coefficient, low impedance resistance tube. The resistance tube has used the stainless steel pipe and the stainless steel radiator fin, in the tube are full of the material (Mgo), has sealed the steel pipe two ends, preventing the moisture to enter to corrupt heating unit quality. Therefore the high quality may maintain for a long time. Using the forced air convection method to cool the resistance tube which can make the resistance tube continuously working

小型、轻巧、占地少 Small-type, light and handy, space saving

干式负荷装置采用了自主研发定型的电阻管，使得负荷装置小型化，全身机架用型材焊接而成，使它的重量更轻，容易搬动。而且占有空间小。可以在较小的空间内做测试工作。

The dry-type load installment has used our self-developed fixed-type resistance tube, which can make the load installment miniaturization. The whole body is insisted of welded materials, for which it is lighter, easier moving and space saving. We can the test work in a small space.

优越的操作性 Superior operation

操作者可以通过本公司研发的软件进行轻松地操作本装置，可调整从0到最大的负荷容量，另外在条件许可的情况下可以在操作面板上预制所帮测试容量。通过一个开关直接投入所需负荷容量，大大提高了工作效率。在种种条件下都能发挥出优秀的可操作性。另外还可以选配远方操作控制箱，在远处就能操纵负荷装置。控制方式有：按钮、控制接触器、PC控制接触器、PLC控制接触器。在PC、PLC控制时可在电脑上显示被测的全部参数，包括电压、电流、频率、有功功率、功率因数等。电脑能够记录和保存测试的数据，可随时调出查看和打印。

The operator can easily operate the installment by our self research and develop software, can regulate the load capacity from 0 to max-value. Further more you can setup the expected capacity on the operation panel directly input the need capacity by switch, which greatly increase the efficiency. Its superiors is obviously in this situation. You can select far-way control box, you can control the load installment far away. The control mode includes: key control contact device, PC control contact device, PLC control contact device. When PC, PLC control may demonstrate the complete parameters on the computer including voltage, current, frequency, active power, power factor and so on. The computer can record and preserve the test data, may momentarily assign out the examination and printing.



负载箱用途 (Application for load bank)

发电机制造业 Motor manufacturing

负载箱是测试发电机的功率、频率、电压、电流、功率因数、发电机的稳定性等参数的理想检测设备。发电机使用的燃料多为柴油，柴油在低于50%负载或长时间空载情况下会造成燃油不充分、积碳、整机效率降低、最终导致启动困难、动力不足、油耗增加、过早开缸维修导致报废，而负载箱是发电机的理想假负载。

The load bank is an ideal test equipment for generator power, the frequency, the voltage, the current, power factor and other generator parameters. Most of the generator use the diesel oil, which can cause the fuel oil unfilled, carbon deposition, complete machine efficiency reduced when the diesel oil load is lower than 50% or in idling situation for a long time and even cause starting difficulty, power insufficiency, oil consumption increased, finally, opening the cylinder for maintenance too early and the abandonment, so the load bank will be generator's ideal false load.

变压器制造业 Transformer manufacturing

测试变压器的额定容量、电流、电压、频率、温升、吵声等参数。铁路、电力、通讯基站电源站负载检测。

Measuring the transformer's parameters include rated capacity, current, voltage, frequency, temperature-rise and noise and so on. As a kind of load testing equipment for power station of the railway, power equipment and transportation.

执行标准 (Normative Standards)

- @ 国际标准: ISO 8528-5:1993 《往复式内燃交流发电机 第5部分: 发电机组》
- @ 国家标准: GB/T 2820.5-1997 《往复式内燃交流发电机 第5部分: 发电机组》
- @ 国家标准: GB/T 13032-1991 《船用柴油发电机组通用技术条件》
- @ 国家标准: GB/T 14048.1-2000 《低压开关设备和控制设备》
- @ 行业标准: JB/T 10303-2001 《工频柴油发电机组技术条件》
- @ 行业标准: JB/T 9696.1-1999 《低压成套开关和控制设备用接线端子排》

- @ International standard: ISO 8528-5: 1993 «Reciprocating internal combustion alternator. Part 5: Generating set.»
- @ National standard: GB/T 2820.5-1997 «Reciprocating internal combustion alternator. Part 5 Generating set.»
- @ National standard: GB/T 13032-1991 «General technical condition for Marine Diesel Generator Set.»
- @ National standard: GB/T 14048.1-2000 «Low-voltage Switchgear and Controlgear.»
- @ Industry standard: JB/T 10303-2001 «Technical condition for Diesel Generating set.»
- @ Industry standard: JB/T 9696.1-1999 «Connecting terminals for Low-voltage Switchgear and Controlgear.»

产品参数 (Product Parameters)

项目 Item	功率 Power		
总功率 Total power	100KW	200KW	400KW
测试电压 Test voltage	三相AC400V Three-phase AC400V	三相AC400V Three-phase AC400V	三相AC400V Three-phase AC400V
功率分段 Power step	5KW X 2段 (step) 10KW X 6段 (step) 20KW X 2段 (step)	2.5KW * 1段 (step) 5KW * 2段 (step) 10KW * 2段 (step) 20KW * 5段 (step) 40KW * 2段 (step)	1kw x1 2kw x1 4kw x1 8kw x1 12kw x2 24kw x4 48kw x6
频率 Frequency	50-60HZ	50-60HZ	50-60HZ
功率因素 Power factor	1.0	1.0	1.0
助电源 Auxiliary power	单相AC220V Single-phase AC220V	二相AC380V Single-phase AC380V	单相AC220V Single-phase AC220V
操作方式 Operation mode	手动 Manual	手动 Manual	手动 Manual
冷却方式 Cooling mode	强制风冷 Forced air cooling	强制风冷 Forced air cooling	强制风冷 Forced air cooling
外形尺寸 Overall dimension	L800 x W820 x H900	L800 x W820 x H1300	L800 x W1250 x H1600
重量 Weight (KG)	150	220	420
选配 Selected fitting	远方控制箱 / 电脑控制 Far-away control box / Computer control	远方控制箱 / 电脑控制 Far-away control box / Computer control	远方控制箱 / 电脑控制 Far-away control box / Computer control

项目 Item	功率 Power		
总功率 Total power	400KW	800KW	1000KW
测试电压 Test voltage	三相AC400V AC220 Three-phase AC400V AC200V	三相AC400V AC220 Three-phase AC400V AC200V	三相AC400V AC220 Three-phase AC400V AC200V
功率分段 Power step	1kw x1 2kw x1 4kw x1 8kw x1 12kw x2 24kw x6 48kw x5	1kw x1 2kw x1 4kw x1 12kw x1 24kw x2 48kw x4 60kw x10	1kw x1 2kw x1 4kw x1 12kw x1 24kw x2 48kw x5 60kw x13
频率 Frequency	50-60HZ	50-60HZ	50-60HZ
功率因素 Power factor	1.0	1.0	1.0
助电源 Auxiliary power	三相+N AC380V Three-phase AC380V	三相+N AC380V Three-phase AC380V	三相+N AC380V Three-phase AC380V
操作方式 Operation mode	手动 Manual	手动 Manual	手动 Manual
冷却方式 Cooling mode	强制风冷 Forced air cooling	强制风冷 Forced air cooling	强制风冷 Forced air cooling
外形尺寸 Overall dimension	L1100 x W1250 x H1600	L800 x W820 x H1300	L800 x W1250 x H1600
重量 Weight (KG)	500	1000	1300
选配 Selected fitting	电脑控制 Computer control	电脑控制 Computer control	电脑控制 Computer control

总功率 Total power	1000KW	2000KW	1000KW
测试电压 Test voltage	三相AC3300V AC6600 Three-phase AC3300V AC6600V	三相AC3300V AC6600 Three-phase AC3300V AC6600V	三相AC3300V AC6600 Three-phase AC3300V AC6600V
功率分段 Power step	0-6kw x1 6kw x5 55kw x3 110kw x8	0-6kw x1 6kw x5 55kw x4 110kw x5 220kw x6	0-12kw x1 6kw x5 60kw x5 120kw x4 240kw x1
频率 Frequency	50-60HZ	50-60HZ	50-60HZ
功率因素 Power factor	1.0	1.0	1.0
助电源 Auxiliary power	三相+N AC380V Three-phase AC380V	三相+N AC380V Three-phase AC380V	三相+N AC380V Three-phase AC380V
操作方式 Operation mode	电脑和手动 Computer&Manual	电脑和手动 Computer&Manual	电脑和手动 Computer&Manual
冷却方式 Cooling mode	强制风冷 Forced air cooling	强制风冷 Forced air cooling	强制风冷 Forced air cooling
外形尺寸 Overall dimension	L3600 x W1250 x H2000	L3600 x W2500 x H2000	L42600 x W 1710 x H2400
重量 Weight (KG)	2200	4500	3200

总功率 Total power	0.77KW	1.53KW	1.53KW	3KW
总电流 Total current	64A	128A	64A	128A
测试电压 Test voltage	DC 12V	DC 12V	DC 24V	DC 24V
功率分段 Power step	5段	5段	5段	5段
助电源 Auxiliary power	单相 AC220V Single phase AC220V	单相 AC220V Single phase AC220V	单相 AC220V Single phase AC220V	单相 AC220V Single phase AC220V
操作方式 Operation mode	"手动 Manual"	"手动 Manual"	"手动 Manual"	"手动 Manual"
冷却方式 Cooling mode	"强制风冷 Forced air cooling"	"强制风冷 Forced air cooling"	"强制风冷 Forced air cooling"	"强制风冷 Forced air cooling"
外形尺寸 Overall dimension	160 x 400 x 300	160x 400 x 300	160 x 400 x 300	160x 400 x 300
重量 Weight (KG)	30	30	30	30

成品识别码 (Product Identification Code)

TRA - 200A - L - Y
 TRA: 3 phase load bank 电流 Current
 DRA: Single phase load bank
 L: Inductive load
 R: Resistance load
 Y:星型 Star
 J:角型 Angle

有源电力滤波器 Active power filters

产品概述 (Product Introduction)

经过多年研发, 已成功应用于众多工业现场, 是当今用于电能优化技术中质量优良, 性能稳定的高科技产品。Active power filter is a high-tech product with excellent quality and stable performance power optimization technology after years of research and development, which has been successfully applied to many industrial sites.

有源滤波器拥有闭环控制系统和对每次谐波独立选择的两大功能。

The Active filter has two functions: a closed-loop control system and independent selection of each harmonic

●闭环控制系统可以检测到电流中每一次谐波的大小和无功功率, 通过与用户设定的目标对比从而实现自动修正。

The closed-loop control system detects the magnitude and reactive power of each harmonic in the current and automatically corrects it by comparing it with the target set by the user.

●对每次谐波进行独立选择的功能来自于先进的算法。滤波器所释放的补偿电流将完美地注入到所选定的目标谐波中, 这保证了用户锁定的目标谐波将会完美滤除。

The ability to independently select each harmonic comes from advanced algorithms. The compensation current released by the filter is perfectly injected into the selected target harmonic, which guarantees the user-locked target harmonic the waves will be filtered out perfectly.

有源电力滤波器闭环控制系统同样可帮助滤波器实现卓越的无功补偿功能和三相平衡功能。

The closed-loop control system of the active power filter also helps the filter achieve excellent reactive power compensation and three-phase balancing functions.

电能质量差带来的损失 Losses due to poor power quality

存在电能质量问题的电气系统将导致成本上升、环境污染和安全隐患在用户的供电系统中, 种类繁多的负载会带来以下三个明显的电能质量问题 Electrical systems with power quality problems will lead to rising costs, environmental pollution and safety hazards in the user's power supply system, a wide variety of loads will bring the following three obvious power quality problems

●谐波污染 Harmonic pollution

●负载不平衡而导致的电压不平衡和相对零电压 Voltage imbalance and relative zero voltage due to load imbalance

●无功功率 Reactive power

电能质量问题带来的不仅仅是金钱上的损失, 它还会带来更多其它问题:

Power quality issues bring more than just monetary losses. It raises many other problems:

●设备故障率上升 The equipment failure rate is rising

●设备寿命下降 Reduced equipment life

●产量下降 Production declined

●配电系统的安全性下降 The safety of the power distribution system is reduced

●增加碳排放 Increase carbon emissions

●无法满足供电局相关规范要求 Unable to meet the relevant specifications of the power supply bureau

此外, 谐波污染还会导致电网中诸如变压器、电缆和马达等设备的有功损耗上升, 这些损耗又将占用发电站的输出能量并导致更多的二氧化碳排放。排放量的大小将取决于整个生产过程和发电所用的燃料类型。

In addition, harmonic pollution can lead to higher active losses in equipment such as transformers, cables, and motors in the grid, which in turn will take up the output energy of the power station and lead to more CO₂ emissions. The magnitude of the emissions will depend on the entire production process and the type of fuel used to generate electricity.

负载平衡式例 Example of load balancing

不带滤波器 Without filter

线电流 Line current 1 49.1Arms
 线电流 Line current 2 5.3Arms
 线电流 Line current 3 5.1Arms

中性线电流
 Neutral current 44.1Arms

带滤波器 With filter

线电流 Line current 1 19.6Arms
 线电流 Line current 2 19.4Arms
 线电流 Line current 3 19.5Arms

中性线电流
 Neutral current 3.5Arms

在电气工程中的设计方法

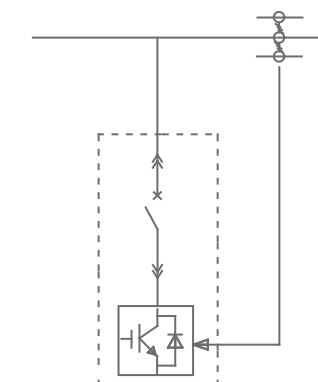

解决方案 Solution

有源电力滤波器能解决谐波污染、三相不平衡和无功补偿等电能质量问题。

The active power filter solves power quality problems such as harmonic pollution, three-phase unbalance and reactive power compensation.

●可应用于不同类型的场合, 并同时适用于商业和工业环境。

It can be used in different types of applications and is suitable for both commercial and industrial environments.

●为客户提供谐波滤除、三相平衡和容性或感性无功补偿。

Provide customers with harmonic filtering, three-phase balancing and capacitive or inductive reactive power compensation.

●通过主从模块的并联扩展, 从几十安培到几千安培的丰富的滤波方案可以为每个系统提供最优化的解决方案。

Through the parallel expansion of the master-slave modules, the rich filtering scheme from tens of amperes to thousands of amperes can provide the most optimized solution for each system.

●有源动态滤波器可安装在低压电网中, 并可通过合适的升压变压器接入中压系统使用。

Active dynamic filters can be installed in low-voltage power grids and can be connected to medium-voltage systems via suitable step-up transformers.

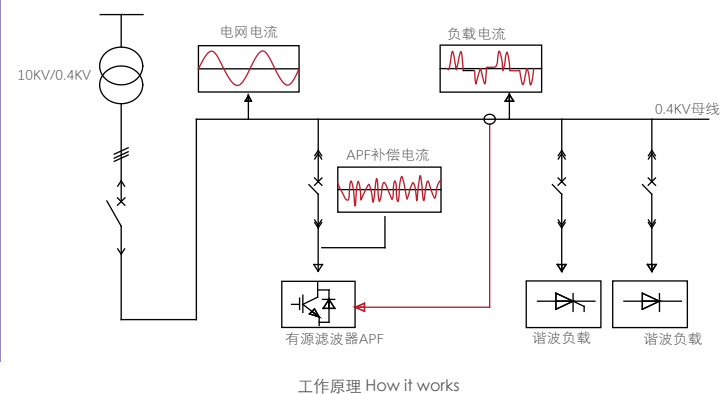

有源电力滤波器为供电系统带来以下好处。

Active power filters bring the following benefits to power delivery systems.

- 减少停机时间
Reduce downtime
- 提高系统运行效率，减少二氧化碳排放
Improve the efficiency of system operation and reduce CO2 emissions
- 满足严格的供电局要求，避免罚款或断电
Meet stringent power bureau requirements and avoid fines or power outages
- 无需对电网的特殊分析，方案实施快而简单
No special analysis of the grid is required, and the implementation of the solution is quick and simple
- 不会过载，特别适用于负载变化快的低压系统
It will not be overloaded, and is especially suitable for low-voltage systems with fast load changes

应用范围 Scope of application

有源电力滤波器可提供不同结构、不同尺寸和不同电容量容量的产品，完全满足不同场合的不同要求。Active power filters can provide products with different structures, different sizes and different current capacities, which can fully meet the different requirements of different occasions.

典型应用行业

- Typical application industries
- 石油和天然气行业（陆地和海上） Oil & Gas Industry (Onshore & Offshore)
 - 钢铁行业 Iron and steel industry
 - 水处理行业 Water treatment industry
 - 水泥行业 Cement industry
 - 汽车行业 Automotive industry
 - 过程控制行业 Process control industry
 - 造纸行业 Paper industry
 - 太阳能行业 Solar energy industry
 - 印刷行业…… Printing industry……

模块化产品为商业和民用以及轻工业场合开发的一款紧凑型产品，同时适用于三相三线和三相四线。墙上安装的模式使得产品适用于空间有限的场合。同样它也能安装在盘柜中。The modular product is a compact product developed for commercial and residential as well as light industrial applications, and is suitable for both three-phase three-wire and three-phase four-wire. The wall-mounted mode makes the product suitable for applications where space is limited. It can also be installed in enclosures.

典型应用行业

- Typical application industries
- 办公室和商业大厦 Office and commercial buildings
 - 计算机和数据中心 Computers and Data Centers
 - 住宅 Residence
 - UPS系统，电梯和照明系统 UPS systems, elevators and lighting systems
 - 轻工业（例：远程泵站） Light industry (e.g. remote pumping stations)
 - 轨道交通…… Rail transit……

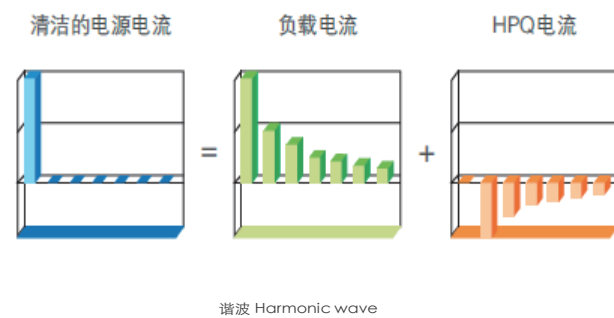

有源滤波控制器 Active filter controller

简单的调试工作在应用过程中尤为重要，同时用户需要实时监视整个网络的电能质量情况。HK-070HE是应用于所有型号的一款标准化用户图形操作界面。它能直接为用户提供滤波器控制、编程和电网参数监视等功能，还具备通讯、故障和实时事件记录等功能。Simple commissioning is especially important during the application process, where users need to monitor the power quality of the entire network in real time. The HK-070HE is a standardized graphical user interface for all models. It can directly provide users with functions such as filter control, programming, and grid parameter monitoring, as well as communication, faults, and real-time events recording and other functions.

全图形化显示
Full graphical display

HK-070HE通过64×132像素的液晶面板，清晰地为用户提供了各类滤波器信息。The HK-070HE provides users with a wide range of filter information through a 64×132 pixel LCD panel.

主要功能如下：

启动、停止和重启滤波器测量、分析和记录各个参数对滤波器进行设定监视滤波器状态和故障记录满足不同场合的不同要求。Start, stop, and restart filters measure, analyze, and record individual parameters, set the filter, and monitor the filter status and fault records meet the different requirements of different occasions.

操作键

Action keys
简单而又友好的操作键让整个操作简单而又直观。Simple and user-friendly keys make the whole operation simple and intuitive.

通讯

Communication
HK-070HE提供了Modbus RTU模式的通讯接口。通过Modbus RS-485转换器（可选），能够接入上位机。所有参数、设定和测量值均能够进行传输。The HK-070HE provides a communication interface in Modbus RTU mode. Pass Modbus RS-485 converter (optional), can be connected to the host computer. All parameters, settings and measured values can be transmitted.

帮助键

Help key
帮助键能够让用户便捷地获得各个功能特性的详细描述。The help button allows the user to easily obtain a detailed description of each function.

调试简单

Commissioning is simple
自动检测和对误接CT进行校正的功能使得调试工作更加简单。Automatic detection and correction of misconnected CT images makes commissioning easier.

用户收益

User Benefits
保护功能降低了停机时间 Protection features reduce downtime
直接获取电网关键参数 Direct access to key grid parameters
适用于不同工况下 It is suitable for different working conditions

尺寸安装

Dimensional mounting
外观尺寸 Exterior dimensions: 203*145*38 mm
开孔尺寸 Cut-out size: 192*138 mm



技术参数 Technical parameters

电气参数

Electrical parameters	
联接方式 Connection mode	三相三线/三相四线 Three-phase three-wire / three-phase four-wire
电压等级 Voltage level	400V/690V (±20%)
电网频率 Grid frequency	50Hz/60Hz (±5%)
滤波电流能力 Filtering current capability	50A 75A 100A 125A 150A
零线谐波滤除能力 Neutral harmonic filtering capability	三倍于相线 Three times as much as the phase
模块数量 Number of modules	≤8 PCS
冗余功能 Redundancy	主主/主从 Master Master/Master Slave
设备损耗 Wear and tear of equipment	≤3%
内部保护装置 Internal protection	短路, 过流, 过压, 过热等 Short circuit, overcurrent, overvoltage, overheating, etc

滤波器参数

Filter parameters	
滤波范围 Filter range	2nd to 51st
谐波选择范围 Harmonic selection range	20次
滤波设定 Filter settings	可对每次谐波电流进行单独设定 Each harmonic current can be set individually
滤波能力 Filtering capabilities	≤5%THDi
整机效率 Overall machine efficiency	≥97.50%
谐波滤除率 Harmonic filtering rate	≥98%
涌入电流 Inrush current	少于额定电流值 Less than the rated current value
限流运转 Current-limited operation	限制在额定电流补偿 Limited to rated current compensation
瞬时响应时间 Instantaneous response time	≤0.1ms
全响应时间 Full response time	≤8ms
噪音（距离1米） Noise (distance of 1 meter)	≤60dB

无功补偿参数

Reactive power compensation parameters	
目标功率因数 Target power factor	可设定0.6（感性）-0.6（容性） Configurable 0.6 (sensitivity) - 0.6 (capacitance)

负载平衡参数

Load balancing parameters	
模式 Mode	相相间 Interphased :ON/OFF

编程 / 通讯

Programming / Communication	
数字输入输出 Digital inputs and outputs	2 digital inputs/6 digital outputs
报警点 Alarm point	1 NO point, 1 NC point

安装

Installation	
海拔 Elevation	≤1500m, indoor installation (1% reduction per 100 meters)
环境温度 Ambient temperature	-10° C 至 40° C
湿度 Humidity	95%, 无凝露 No condensation

订货资料 - 选型表 Ordering Information - Selection Table

模块组合示例400V

Module combination example 400V

滤波电流 Filtering current	APF 模块组合
50A	APF-400V-50A-XL
75A	APF-400V-75A-XL
100A	APF-400V-100A-XL
125A	APF-400V-125A-XL
150A	APF-400V-150A-XL
200A	APF-400V-100A-XL*2
250A	APF-400V-125A-XL*2
300A	APF-400V-150A-XL*2
350A	APF-400V-100A-XL*2+HPQ-APF-400V-150A-XL
400A	APF-400V-100A-XL+HPQ-APF-400V-150A-XL*2
450A	APF-400V-150A-XL*3
500A	APF-400V-50A-XL+HPQ-APF-400V-150A-XL*3
550A	APF-400V-100A-XL+HPQ-APF-400V-150A-XL*3
600A	APF-400V-150A-XL*4

产品尺寸 Product dimensions

抽屉式 Drawer style

规格	外形尺寸(mm)						
	H1	H2	W1	W2	W3	D1	D2
50A	165	100	470	452	451	415	140
75A	165	100	470	452	451	415	140
100A	220	150	545	522	521	614	170
150A	220	150	545	522	521	614	170

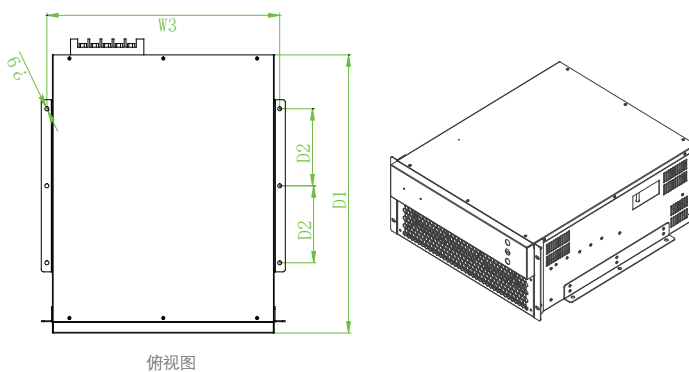
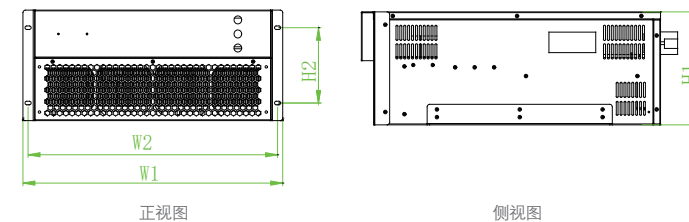

壁挂式 Wall-mounted

规格	外形尺寸(mm)				
	H1	W1	W2	D1	D2
50A	190	430	451	460	140
75A	190	430	451	460	140
100A	250	496	521	589	170
150A	250	496	521	589	170

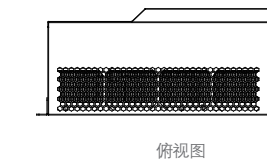
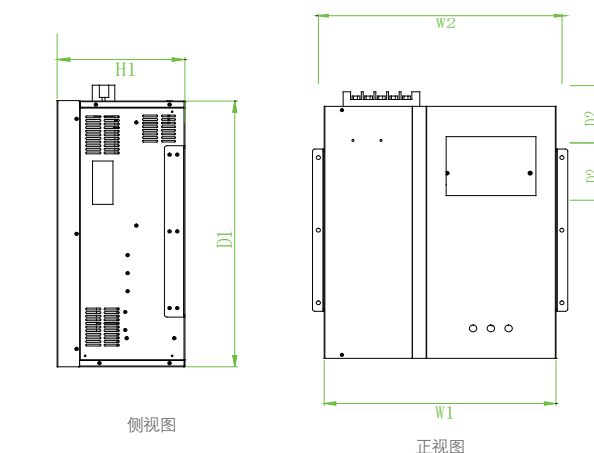

Static Var Generator (SVG)

Static Var Generator (SVG) employs a three-level topology and advanced control algorithms, delivering significant advantages including high power density, exceptional efficiency, low cost, and minimal noise emission. The core module dynamically eliminates harmonics and precisely regulates reactive power, enabling rapid, continuous output of capacitive or inductive reactive power. This effectively:

- Enhances system power factor
- Reduces system losses
- Suppresses harmonic pollution

Reliability Features:

- Single modules operate independently with robust reliability
- During multi-unit compensation: failure of one unit does not compromise operation of others
- Industry-leading N+1 redundancy architecture

Recognized as the most advanced solution in reactive power compensation systems.

Operational Principle:

The static VAR generator (SVG) detects the load current in real time through an external current transformer (CT), and analyzes the reactive content of the load current through internal DSP calculation, and then controls the PWM signal generator to send a control signal to the internal IGBT according to the set value to make the inverter generate reactive compensation current that meets the requirements, ultimately achieving the purpose of dynamic reactive compensation, and at the same time has a certain harmonic compensation capability.

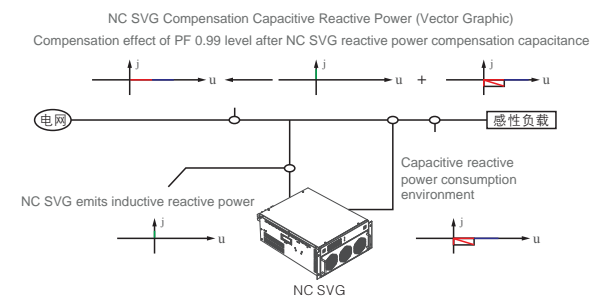
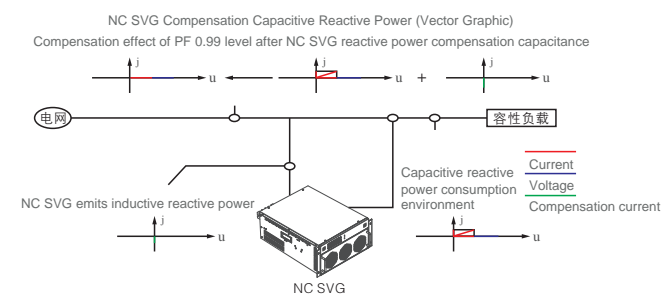

技术参数 Technical parameters

Capacity	30 Kvar				50 Kvar				75 Kvar				100 Kvar			
	Larger capacity can be achieved through parallel expansion and coordinated by a centralized control system															
Rated Voltage	400V/(±20%)															
Phase / Wlre	3 phase 3 wlres / 3 phase 4 wires															
Frequency	50Hz/60Hz (± 5%)															
Topology	Three-Level NPC															
Reactive compensation	-1~1 adjustable															
3 phase unbalance compensation capacity	< 3%															
Compensation method	Primarily designed for reactive power compensation, with optional harmonic compensation capability															
Ractive compensation rate	≥98%															
Efficiency	0.975															
Inrush Current	Less than rated current value															
Current limiting operation	Compensation current limited to rated value															
Transient response time	≤0.1ms															
Full response time	≤8ms															
Noise	≤60dB															
HMI	7" (4.3")															
Hardware interface	RS485, RJ45															
Communication protocol	RS485, 232, TCP/IP selectable															
Cooling method	Intelligent air cooling															
Protection function	Short circuit, overcurrent, overvoltage, overheating, etc.															
Protection rating	IP20															
Ambient temperature	-10°C to +40°C															
Storage temperature	-20°C to +70°C															
	Maximum humidity 95%, no condensation															
Altitude	< 1500 metres(capacity decreases by 1% for every additional 100 metres)															
Module weight																

产品尺寸 Product dimensions

壁挂式 Wall-mounted

Specifications	External dimensions(mm)				Centre distance between mounting holes(mm)	
	(H1)	(H2)	(W)	(D)	(C1)	(C2)
35Kvar	628	550	445	254	300	602.5
50Kvar	628	550	445	254	300	602.5
75Kvar	628	550	445	254	300	602.5
100Kvar	628	550	445	254	300	602.5
150Kvar	768	690	500	254	300	602.5

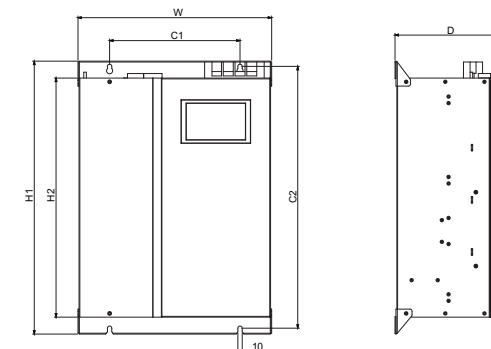

抽屉式 Drawer style

Specifications	External dimensions(mm)				Centre distance between mounting holes(mm)			
	(H1)	(W1)	(W2)	(D1)	(D2)	(C2)	(C2)	
35Kvar	230	440	497	550	620	150	470	
50Kvar	230	440	497	550	620	150	470	
75Kvar	230	440	497	550	620	150	470	
100Kvar	230	440	500	550	620	150	470	
150Kvar	230	495	552	690	760	150	525	

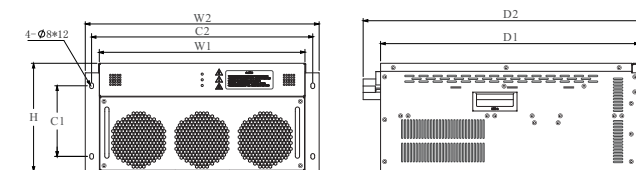

安装方式 Installation method

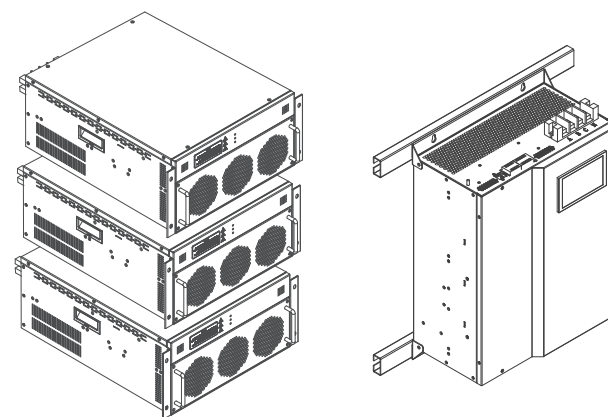

接线方式 Wiring method

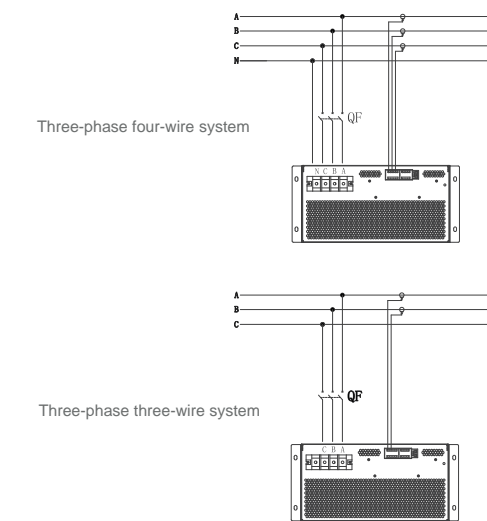

Model Description

