

# PRODUCT CATALOGUE POWER MODULE.

由于产品的更新迭代,本产品型录的部分参数数据会产生变化,建议您在查阅本产品型录的同时,请联系我们,以便您及时获得最新的资讯。

All technical data, drawings and product information contained here may be subject to change, in order to provide you with a continuously improved products, please contact with us for up to date information.

# COMPANY

## INTRODUCTION

### 公司简介

## Vishayd Electric Technology Co.,Ltd

- 成立于**2020**年
- 致力于高端功率半导体器件国产化
- 专注于功率半导体器件的设计开发、系统应用和智能制造
- 集研发、生产、销售和服务为一体的创新型科技企业
- 产品：工业级和车规级的IGBT/SiC模块、IPM智能功率模块和分立器件
  
- Founded in **2020**
- Committed to the localization of high-end power semiconductor devices.
- Focus on R&D, system application and intelligent manufacturing for power semiconductors.
- An innovative technology enterprise collects together R&D, manufacturing, and sales.
- Various types of power semiconductor devices (IGBT/SiC module, IPM module and Discrete) for automotive qualified & industrial qualified.



### 总部&制造基地——上海 HQ & Manufacturing Base——Shang Hai

- 研发中心：研发技术、新品导入
- 运营中心：人才引进、产品评估
- 制造工厂：5000m<sup>2</sup>  
封装产线：2条  
IGBT产量约100万颗
- R&D Center:  
R&D technology, NPI Dep. Product Evaluation
- Operation Center:  
Talent Introduction, Application Evaluation
- Manufacture Factory: 5000m<sup>2</sup>  
2 production lines  
1 million pcs / Annual Production

### 制造基地——浙江 Manufacturing Base——Zhe Jiang

- 实验中心、工程技术、批量生产
- 智能工厂：20000m<sup>2</sup>  
规划产线：10条（分期完成）  
一期产量约325万颗（3条产线）
- Advanced Laboratory, Engineering Technology,  
Volume Production
- 20000m<sup>2</sup> Manufacture Factory  
(completion by stages with 10 production lines)
- Phase I project : 3 production lines  
(325 million pcs / Annual Production)

### 研发中心——台湾 R&D Center——Tai Wan

# IGBT & SiC 模块命名规则

TYPE DEFINITION FOR IGBT & SiC MODULE

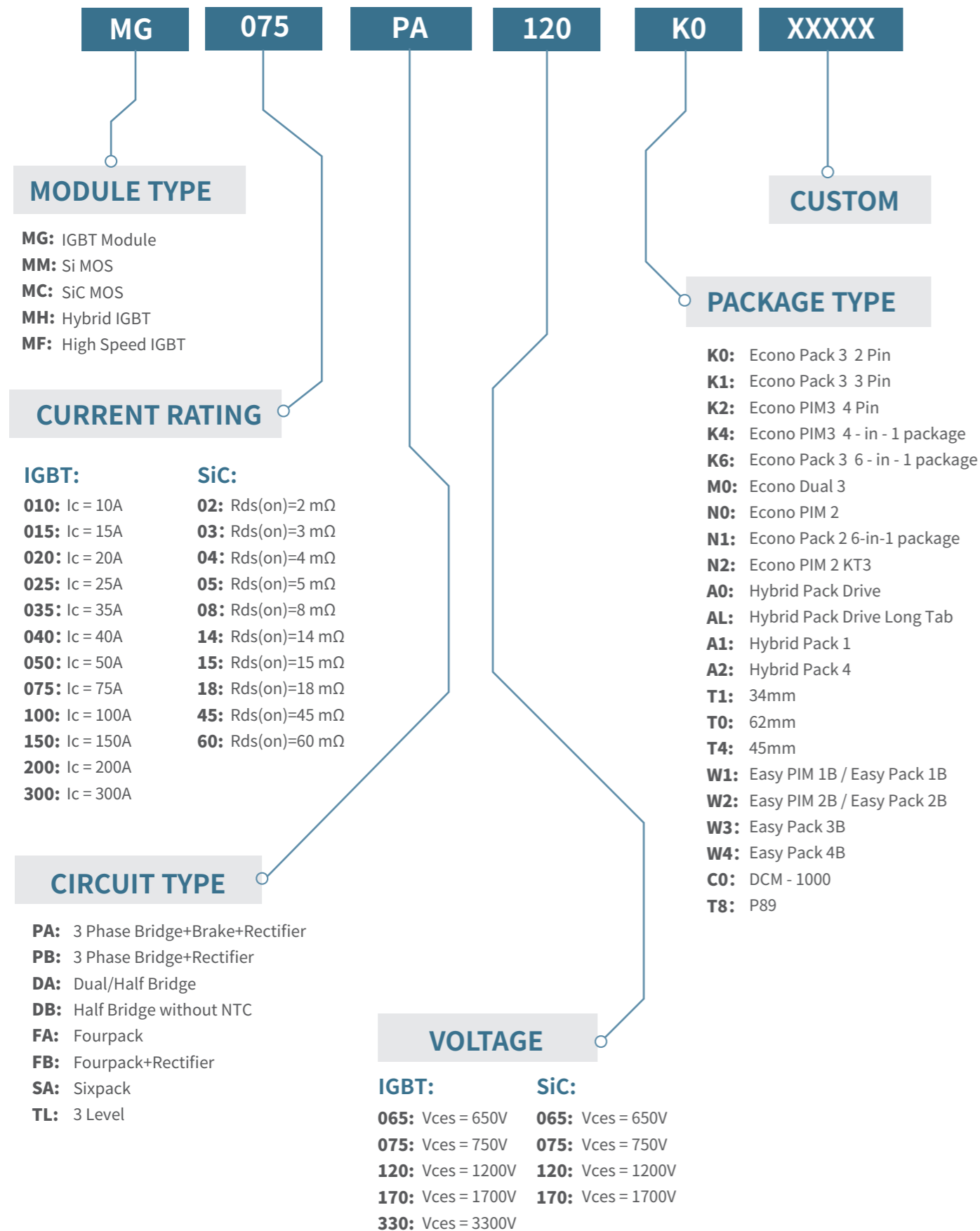

# 单管命名规则

TYPE DEFINITION FOR DISCRETE

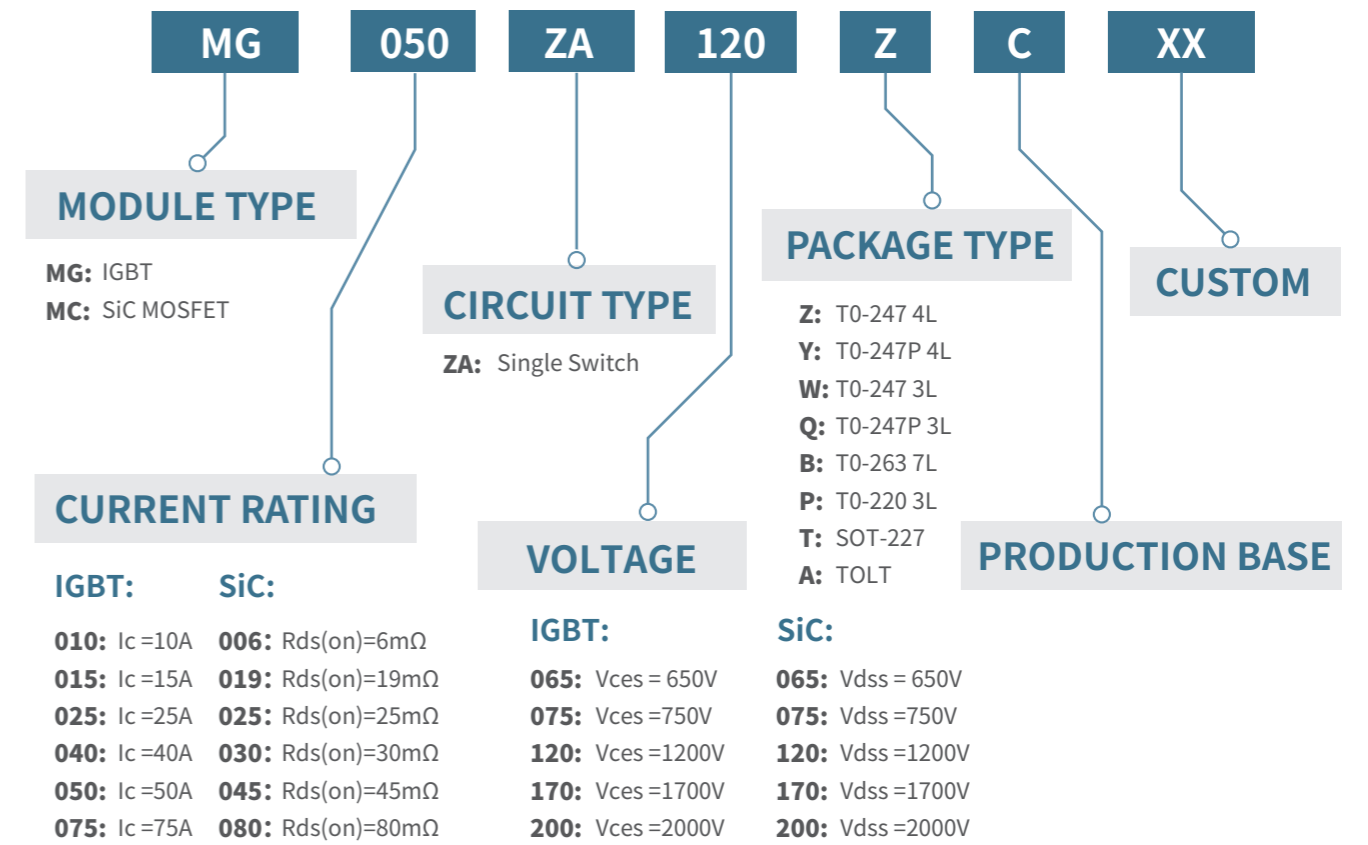

# IPM命名规则

TYPE DEFINITION FOR IPM

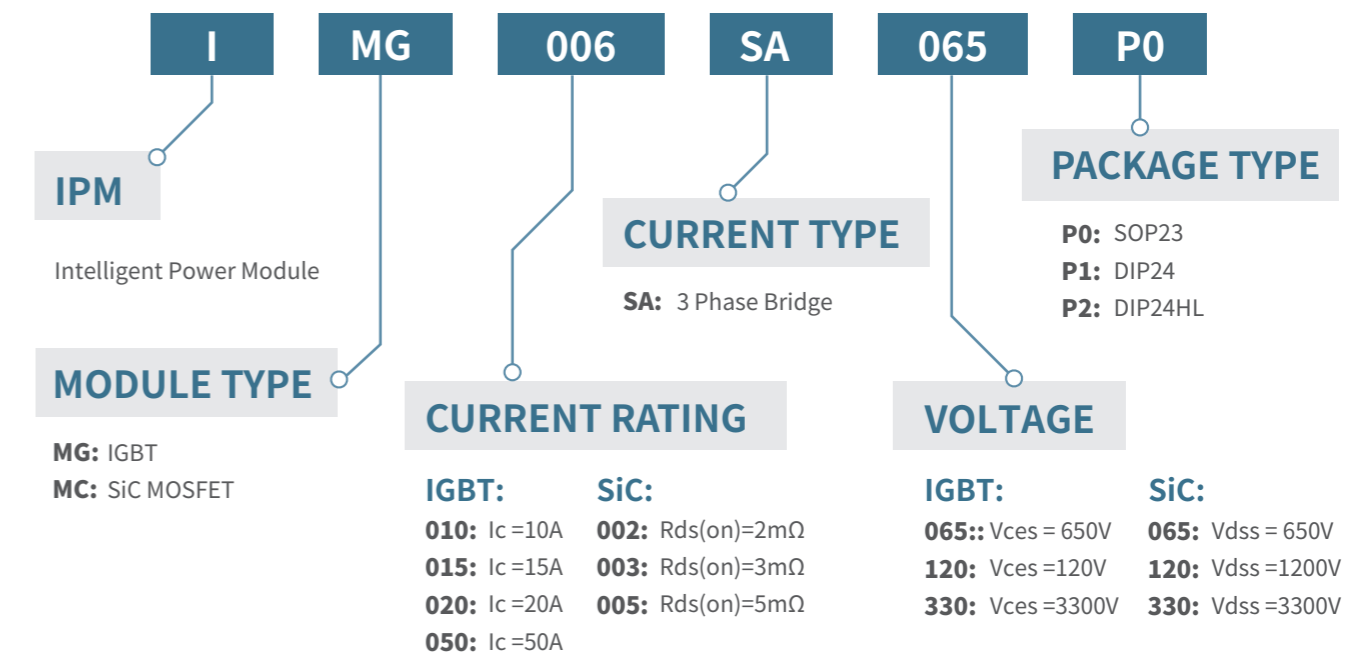

# Easy 1B

## PA系列 (PA series: 3 Phase Bridge+Brake+Rectifier) SA系列 (SA series: Sixpack)

额定电压 Rated Voltage: 650V / 1200V  
电流范围 Current Range: 10A / 15A / 20A / 30A / 35A / 50A

### 行业应用 Applications

工业变频器、工业伺服、不间断电源UPS、感应加热、功率电源、储能、风力发电、太阳能光伏、新能源汽车

Frequency converters, Industrial servo controller, Uninterrupted power supply (UPS), Inverter welder, Induction heater, Energy storage, Wind power, PV solar, New energy vehicles, etc.



### 外型尺寸图 Outline Dimension

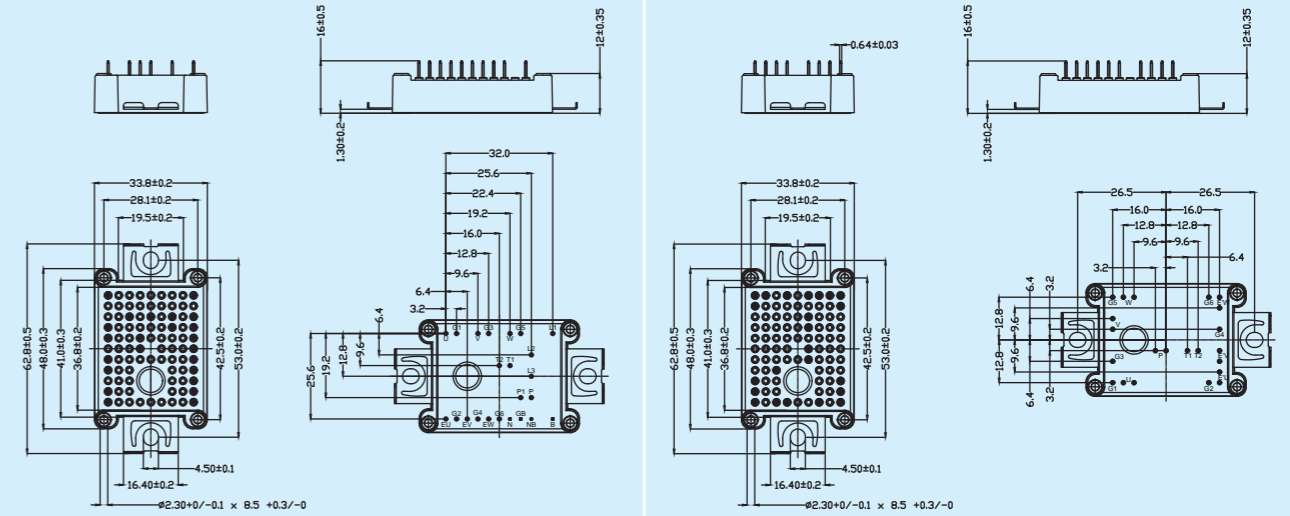

PA Series

SA Series

产品型号 Part Number	Vces (V)	Ic (A)	Vce(sat) Tj=25 °C (V)	电路拓扑结构 Configuration	封装 Housing
MG030PA065W1	650	30	1.58	3 Phase Bridge+Brake+Rectifier	W1
MG010PA120W1	1200	10	1.74	3 Phase Bridge+Brake+Rectifier	W1
MG015PA120W1	1200	15	1.77	3 Phase Bridge+Brake+Rectifier	W1
MG025PA120W1	1200	25	1.78	3 Phase Bridge+Brake+Rectifier	W1
MG030SA065W1	650	30	1.59	Sixpack	W1
MG015SA120W1	1200	15	1.77	Sixpack	W1
MG025SA120W1	1200	25	1.78	Sixpack	W1
MG035SA120W1	1200	35	1.71	Sixpack	W1
MG050SA120W1	1200	50	1.75	Sixpack	W1

### 拓扑 Circuit Diagram

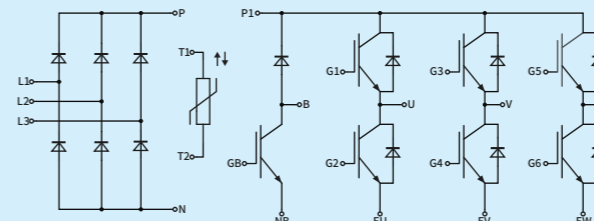

PA Series

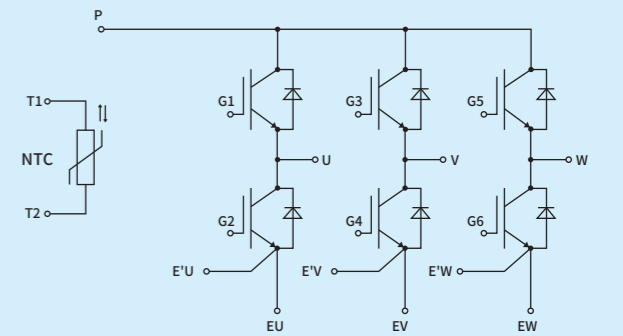

SA Series

# EASY 2B

**PA系列 (PA series: 3 Phase Bridge+Brake+Rectifier)**

**DA系列 (DA series: Half Bridge)**

**SA系列 (SA series: Sixpack)**

**TL系列 (TL series: 3 Level)**

额定电压 Rated Voltage: 650V / 1200V

电流范围 Current Range: 15A / 25A / 35A / 40A / 50A / 75A / 100A / 150A

**DA系列 碳化硅 (DA series SiC: Dual/Half Bridge)**

额定电压 Rated Voltage: 1200V

导通阻抗 Turn-on Resistance: 3.52mΩ

## 行业应用 Applications

工业变频器、工业伺服、不间断电源UPS、功率电源、储能、太阳能光伏、新能源汽车

Frequency converters, Industrial servo controller, Uninterrupted power supply (UPS), Inverter welder, Energy storage, PV solar, New energy vehicles, etc.



产品型号 Part Number	Vces (V)	Ic (A)	Vce(sat) Tj=25°C (V)	电路拓扑结构 Configuration	封装 Housing
MG075TL065W2	650	75	1.45	3 Level	W2
MG100TL065W2	650	100	1.90	3 Level	W2
MG150TL065W2	650	150	1.37	3 Level	W2
MG050PA065W2	650	50	1.35	3 Phase Bridge+Brake+Rectifier	W2
MG025PA120W2	1200	25	1.75	3 Phase Bridge+Brake+Rectifier	W2
MG035PA120W2	1200	35	1.70	3 Phase Bridge+Brake+Rectifier	W2
MG040PA120W2	1200	40	1.71	3 Phase Bridge+Brake+Rectifier	W2
MG050PA120W2	1200	50	1.70	3 Phase Bridge+Brake+Rectifier	W2
MG050SA120W2	1200	50	1.71	Sixpack	W2
MG075SA120W2	1200	75	1.70	Sixpack	W2
MG100SA120W2	1200	100	1.72	Sixpack	W2
产品型号 Part Number	Vdss (V)	Rds(on) Tj=25°C (mΩ)		电路拓扑结构 Configuration	封装 Housing
MC04DA120W2	1200	3.52		Half Bridge	W2
MC08DA120W2	1200	7.65		Half Bridge	W2
MC14SA120W2	1200	13.92		Sixpack	W2

## 外型尺寸图 Outline Dimension

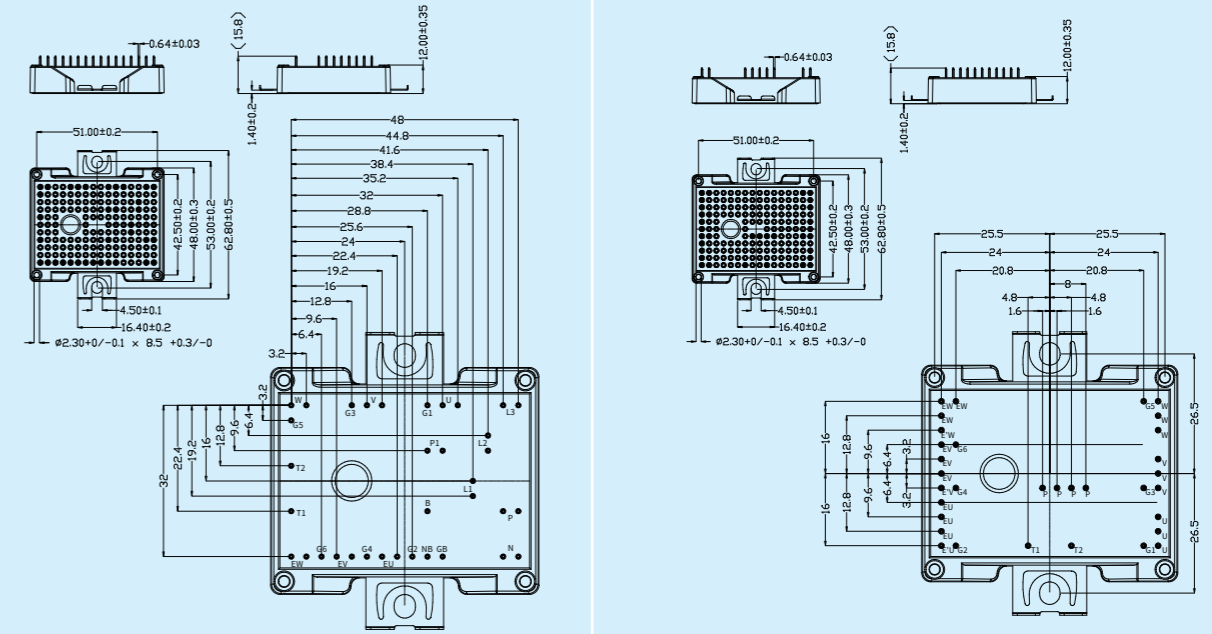

PA series

SA series

## 拓扑 Circuit Diagram

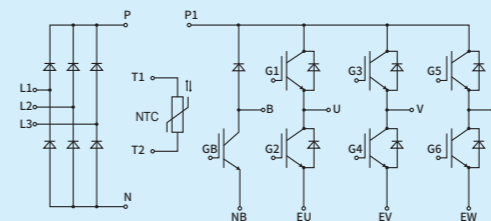

PA series

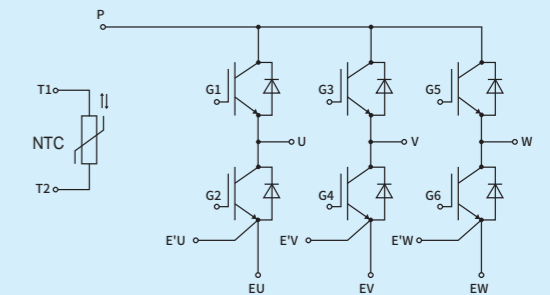

SA series

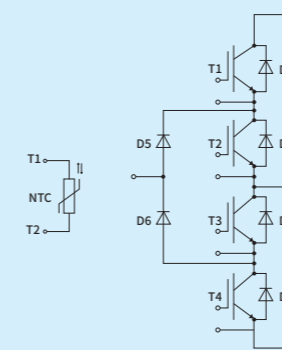

TL series

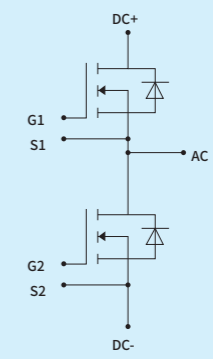

DA series

# EconoPIM2

**PA系列 (PA series: 3 Phase Bridge+Brake+Rectifier)**

**PB系列 (PB series: 3 Phase Bridge+Rectifier)**

**SA系列 (SA series: Sixpack)**

额定电压 Rated Voltage: 650V / 1200V

电流范围 Current Range: 25A / 35A / 40A / 50A / 75A / 100A



## 行业应用 Applications

工业变频器、工业伺服、不间断电源UPS、电焊机、感应加热、风力发电、太阳能光伏、轨道交通等

Frequency converters, Industrial servo controller, Uninterrupted power supply (UPS), Inverter welder, Induction heater, Wind power, PV solar, Rail Transit, etc.

产品型号 Part Number	Vces (V)	Ic (A)	Vce(sat) Tj=25 °C (V)	电路拓扑结构 Configuration	封装 Housing
MG050PA065N0	650	50	1.75	3 Phase Bridge+Brake+Rectifier	N0
MG050PA065N2	650	50	1.68	3 Phase Bridge+Brake+Rectifier	N2
MG050PA065N3	650	50	1.40	3 Phase Bridge+Brake+Rectifier	N3
MG075PA065N3	650	75	1.69	3 Phase Bridge+Brake+Rectifier	N3
MG025PA120N0	1200	25	1.75	3 Phase Bridge+Brake+Rectifier	N0
MG025PA120N2	1200	25	1.75	3 Phase Bridge+Brake+Rectifier	N2
MG035PA120N0	1200	35	1.52	3 Phase Bridge+Brake+Rectifier	N0
MG040PA120N2	1200	40	1.58	3 Phase Bridge+Brake+Rectifier	N2
MG050PA120N0	1200	50	1.70	3 Phase Bridge+Brake+Rectifier	N0
MG050PA120N2	1200	50	1.70	3 Phase Bridge+Brake+Rectifier	N2
MG075PA120N3	1200	75	1.70	3 Phase Bridge+Brake+Rectifier	N3
MG100PA120N3	1200	100	1.72	3 Phase Bridge+Brake+Rectifier	N3
MG050PB120N0	1200	50	1.70	3 Phase Bridge+Rectifier	N0
MG075PB120N3	1200	75	1.85	3 Phase Bridge+Rectifier	N3
MG50SA120N1	1200	50	1.70	Sixpack	N1
MG075SA120N1	1200	75	1.54	Sixpack	N1
MG100SA120N1	1200	100	1.85	Sixpack	N1
MF075FA120N4	1200	75	2.15	Fourpack	N4

## 外型尺寸图 Outline Dimension

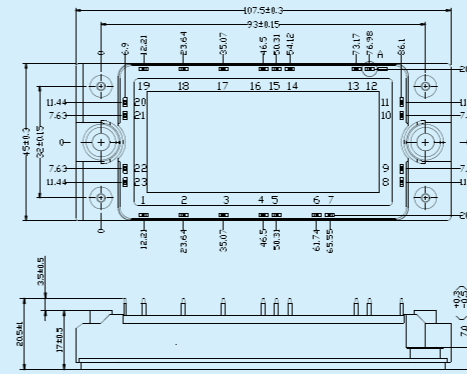

PA, PB series

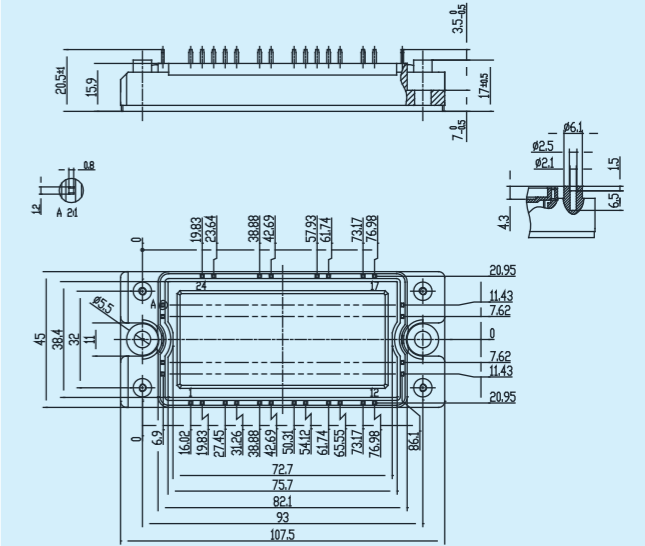

SA series

## 拓扑 Circuit Diagram

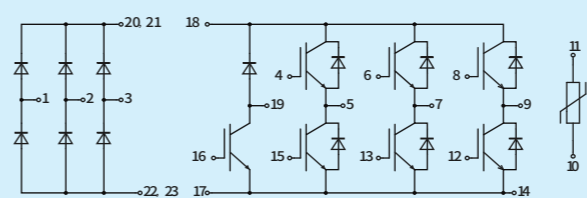

PA series

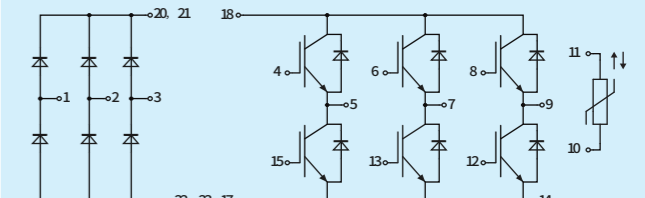

PB series

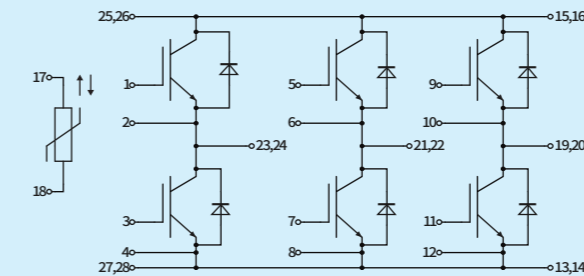

SA series

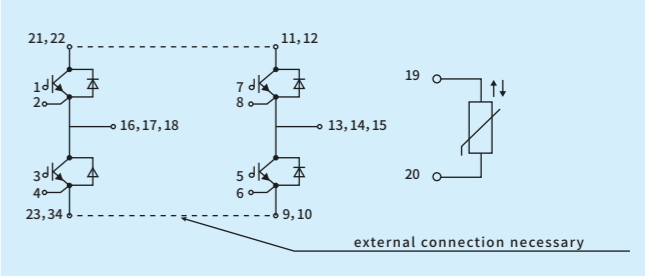

FA series

# EconoPIM3

**PA系列 (PA series: 3 Phase Bridge+Brake+Rectifier)**

**PB系列 (PB series: 3 Phase Bridge+Rectifier)**

**SA系列 (SA series: Sixpack)**

**FB系列 (FB series: Fourpack+Rectifier)**

**FA系列 (FA series: Fourpack)**

额定电压 Rated Voltage: 650V / 750V / 1200V / 1700V

电流范围 Current Range: 50A / 75A / 100A / 150A / 200A / 275A / 300A



## 行业应用 Applications

工业变频器、工业伺服、不间断电源UPS、电焊机、感应加热、风力发电、太阳能光伏、轨道交通、新能源汽车

Frequency converters, Industrial servo controller, Uninterrupted power supply (UPS), Inverter welder, Induction heater, Wind power, PV solar, Rail Transit, New energy vehicles, etc.

产品型号 Part Number	Vces (V)	Ic (A)	Vce(sat) Tj=25 °C (V)	电路拓扑结构 Configuration	封装 Housing
MG075PA065K0	650	75	1.67	3 Phase Bridge+Brake+Rectifier	K0
MG075PA065K3	650	75	1.63	3 Phase Bridge+Brake+Rectifier	K3
MG100PA065K3	650	100	1.19	3 Phase Bridge+Brake+Rectifier	K3
MG200PA065K1	650	200	1.37	3 Phase Bridge+Brake+Rectifier	K1
MG200PB065K1	650	200	1.37	3 Phase Bridge+Rectifier	K1
MG050PA120K0	1200	50	1.67	3 Phase Bridge+Brake+Rectifier	K0
MG050PA120K3	1200	50	1.67	3 Phase Bridge+Brake+Rectifier	K3
MG075PA120K0	1200	75	1.54	3 Phase Bridge+Brake+Rectifier	K0
MG075PA120K3	1200	75	1.54	3 Phase Bridge+Brake+Rectifier	K3
MG100PA120K0	1200	100	1.84	3 Phase Bridge+Brake+Rectifier	K0
MG150PA120K1	1200	150	1.45	3 Phase Bridge+Brake+Rectifier	K1
MG200PA120K2	1200	200	1.59	3 Phase Bridge+Brake+Rectifier	K2
MG075PB120K0	1200	75	1.54	3 Phase Bridge+Rectifier	K0
MG100PB120K0	1200	100	1.84	3 Phase Bridge+Rectifier	K0
MG150PB120K1	1200	150	1.45	3 Phase Bridge+Rectifier	K1
MG150FA120K5	1200	150	1.54	Fourpack	K5
MG075FB170K4	1700	75	1.80	Fourpack+Rectifier	K4
MG150FB170K4	1700	150	1.80	Fourpack+Rectifier	K4
MG200FB170K4	1700	200	1.92	Fourpack+Rectifier	K4
MG100SA065K6	650	100	1.20	Sixpack	K6
MG200SA065K6	650	200	1.37	Sixpack	K6
MG300SA065K7	650	300	1.54	Sixpack	K7
MG075SA120K6	1200	75	1.54	Sixpack	K6
MG100SA120K6	1200	100	1.84	Sixpack	K6
MG150SA120K6	1200	150	1.45	Sixpack	K6
MG200SA120K6	1200	200	1.59	Sixpack	K6
MG200SA120K7	1200	200	1.59	Sixpack	K7
MG300SA120K7	1200	300	1.80	Sixpack	K7
MG075SA170K6	1700	75	1.79	Sixpack	K6
MG100SA170K6	1700	100	1.80	Sixpack	K6
MG150SA170K6	1700	150	1.75	Sixpack	K6

外型尺寸图  
Outline Dimension

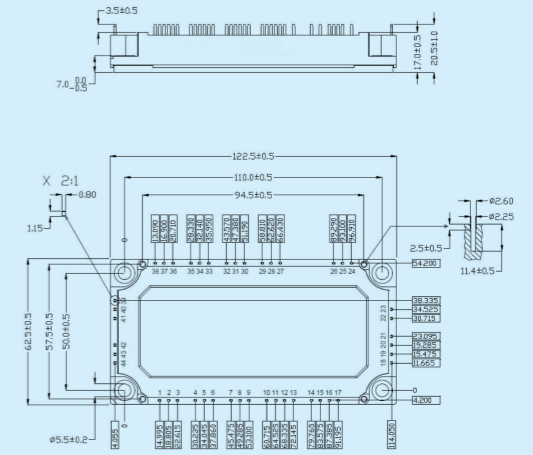
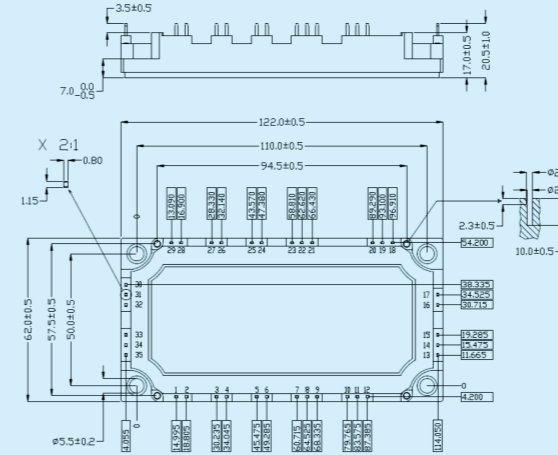

拓扑  
Circuit Diagram

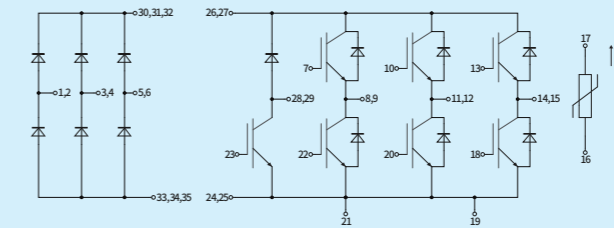

PA PB series

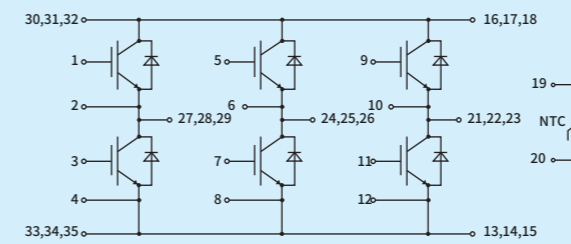

SA series (K6)

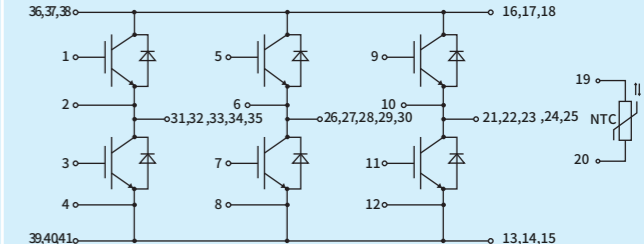

SA series (K7)

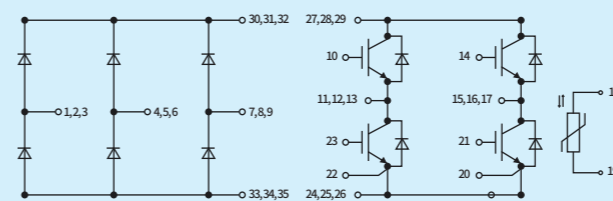

FB series (K4)

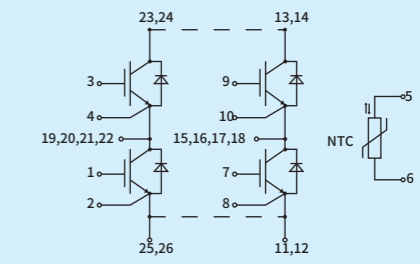

FA series (K5)

# Y34mm

## DB系列 (DB series: Half Bridge without NTC)

额定电压 Rated Voltage: 650V / 1200V / 1700V  
 电流范围 Current Range: 75A / 100A / 150A / 200A / 225A / 300A

## 行业应用 Applications

工业变频器、电焊机、感应加热、不间断电源UPS、电机制动、太阳能光伏  
 Frequency converters, Inverter welder, Induction heater, Uninterrupted power supply (UPS), Motor control, PV solar.



产品型号 Part Number	Vces (V)	Ic (A)	Vce(sat) Tj=25 °C (V)	电路拓扑结构 Configuration	封装 Housing
MG075DB065T1	650	75	1.42	Half Bridge	T1
MG100DB065T1	650	100	1.35	Half Bridge	T1
MG150DB065T1	650	150	1.37	Half Bridge	T1
MG200DB065T1	650	200	1.40	Half Bridge	T1
MG300DB065T1	650	300	1.31	Half Bridge	T1
MF225DB065T1	650	225	1.26	Half Bridge	T1
MG050DB120T1	1200	50	1.71	Half Bridge	T1
MG075DB120T1	1200	75	1.63	Half Bridge	T1
MG100DB120T1	1200	100	1.86	Half Bridge	T1
MG150DB120T1	1200	150	1.45	Half Bridge	T1
MG200DB120T1	1200	200	1.62	Half Bridge	T1
MF075DB120T1	1200	75	2.15	Half Bridge	T1
MF100DB120T1	1200	100	1.92	Half Bridge	T1
MF150DB120T1	1200	150	2.10	Half Bridge	T1
MG075DB170T1	1700	75	1.78	Half Bridge	T1
MG100DB170T1	1700	100	1.66	Half Bridge	T1
MG150DB170T1	1700	150	1.81	Half Bridge	T1

外型尺寸图  
Outline Dimension

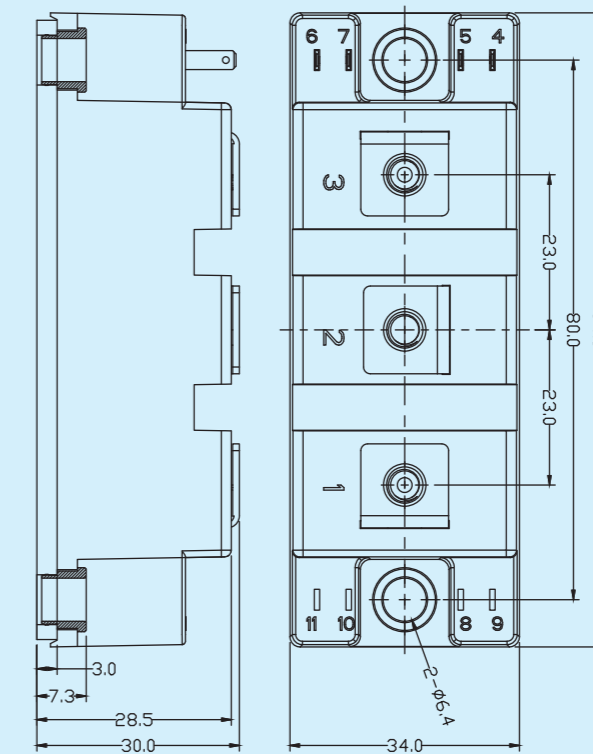

拓扑  
Circuit Diagram

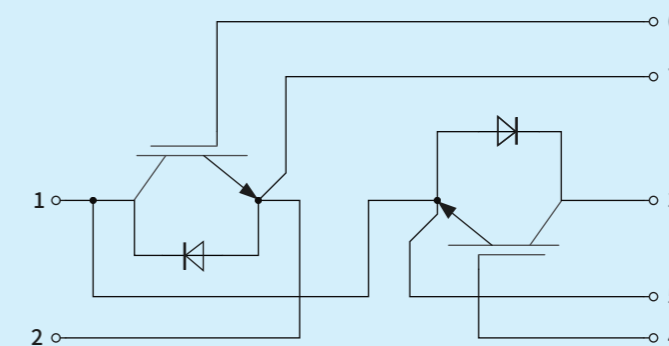



# Y62mm

## DB系列 (DB series: Half Bridge without NTC)

额定电压 Rated Voltage: 650V / 1200V / 1700V  
 电流范围 Current Range: 150A / 200A / 300A / 400A / 450A / 600A / 800A

## DB系列 碳化硅 (DB series: Half Bridge without NTC)

额定电压 Rated Voltage: 1200V  
 导通阻抗 Turn-on Resistance: 3.5mΩ



## 行业应用 Applications

储能、风力发电、工业变频器、不间断电源UPS、功率电源、可再生能源、电源质量APF、SVG等  
 Energy storage, Wind power converter, Frequency converters, Uninterrupted power supply (UPS), Active filters, Renewable energy, Active Power Filter (APF), Static VAR Generator (SVG), etc.

产品型号 Part Number	Vces (V)	Ic (A)	Vce(sat) Tj=25°C (V)	电路拓扑结构 Configuration	封装 Housing
MG150DB065T0	650	150	1.37	Half Bridge	T0
MG200DB065T0	650	200	1.36	Half Bridge	T0
MG400DB065T0	650	400	1.40	Half Bridge	T0
MG600DB065T0	650	600	2.00	Half Bridge	T0
MG800DB065T0	650	800	2.01	Half Bridge	T0
MF300DB065T0	650	300	2.18	Half Bridge	T0
MG150DB120T0	1200	150	1.43	Half Bridge	T0
MG200DB120T0	1200	200	1.63	Half Bridge	T0
MG300DB120T0	1200	300	1.55	Half Bridge	T0
MG450DB120T0	1200	450	1.45	Half Bridge	T0
MG600DB120T0	1200	600	1.45	Half Bridge	T0
MF200DB120T0	1200	200	2.05	Half Bridge	T0
MF300DB120T0	1200	300	2.19	Half Bridge	T0
MF400DB120T0	1200	400	2.27	Half Bridge	T0
MB300DB120T0	1200	300	1.55	Half Bridge	T0
MB450DB120T0	1200	450	1.45	Half Bridge	T0
MB600DB120T0	1200	600	1.45	Half Bridge	T0
MG150DB170T0	1700	150	1.58	Half Bridge	T0
MG200DB170T0	1700	200	1.65	Half Bridge	T0
MG300DB170T0	1700	300	1.90	Half Bridge	T0
MG450DB170T0	1700	450	1.91	Half Bridge	T0
MG600DB170T0	1700	600	1.72	Half Bridge	T0
产品型号 Part Number	Vdss (V)	Rds(on) Tj=25°C (mΩ)	电路拓扑结构 Configuration	封装 Housing	
MC04DB120T0	1200	3.50	Half Bridge	T0	
MC03DB120T0	1200	3.13	Half Bridge	T0	
MC04CE120T0	1200	3.80	Contralateral tube	T0	

外型尺寸图  
Outline Dimension

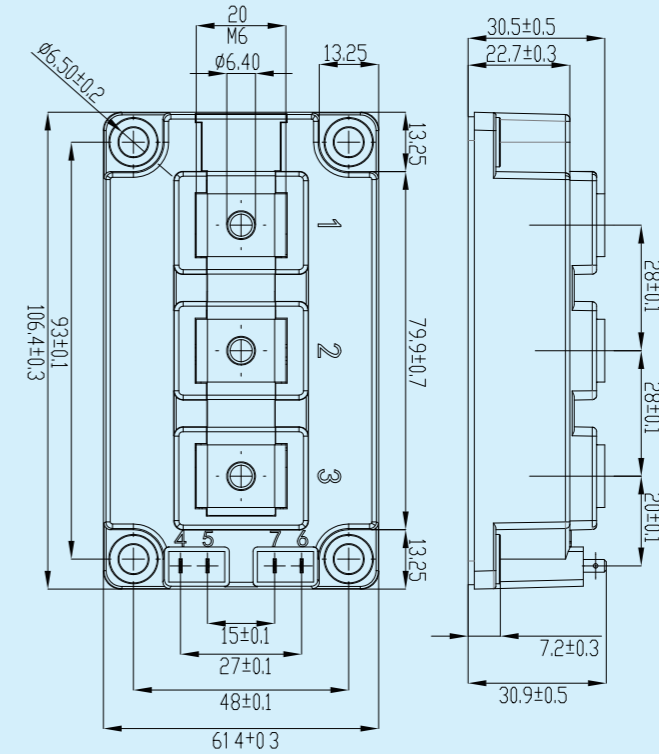

拓扑  
Circuit Diagram

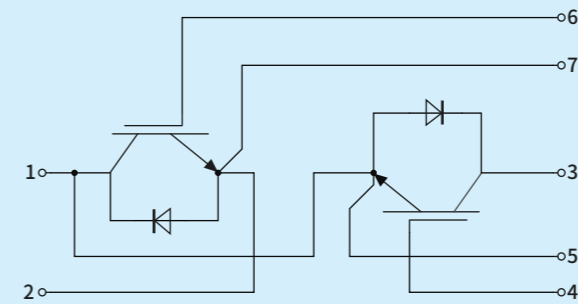

IGBT Series

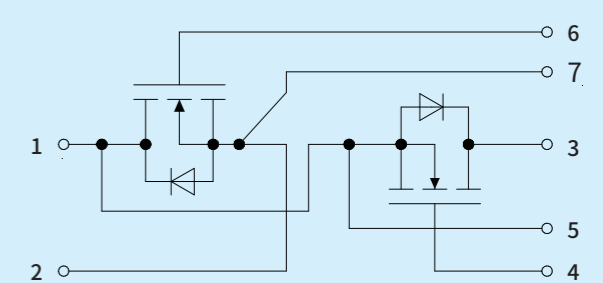

SiC Series

# EconoDual3

## DA系列 (DA series: Dual/Half Bridge)

额定电压 Rated Voltage: 650V / 1200V / 1700V  
 电流范围 Current Range: 150A / 300A / 450A / 600A / 800A / 900A

## DA系列 碳化硅 (DA series SiC: Dual/Half Bridge)

额定电压 Rated Voltage: 1200V  
 导通阻抗 Turn-on Resistance: 1.55mΩ / 2.3mΩ / 4.7mΩ



## 行业应用 Applications

工业变频器、工业伺服、不间断电源UPS、感应加热、储能、风力发电、太阳能光伏、轨道交通、新能源汽车

Frequency converters, Industrial servo controller, Uninterrupted power supply (UPS), Induction heater, Energy storage, Wind power, PV solar, Rail Transi, New energy vehicles, etc.

产品型号 Part Number	Vces (V)	Ic (A)	Vce(sat) Tj=25°C (V)	电路拓扑结构 Configuration	封装 Housing
MG300DA065M0	650	300	1.85	Half Bridge (NTC)	M0
MG450DA065M0	650	450	1.42	Half Bridge (NTC)	M0
MG600DA065M0	650	600	1.91	Half Bridge (NTC)	M0
MB600DA065M0	650	600	1.91	Half Bridge (NTC)	M0
MF600DA065M0	650	600	2.00	Half Bridge (NTC)	M0
MG300DA120M0	1200	300	1.55	Half Bridge (NTC)	M0
MG450DA120M0	1200	450	1.50	Half Bridge (NTC)	M0
MG600DA120M0	1200	600	1.70	Half Bridge (NTC)	M0
MG900DA120M0	1200	900	1.80	Half Bridge (NTC)	M0
MB450DA120M0	1200	450	1.50	Half Bridge (NTC)	M0
MB600DA120M0	1200	600	1.70	Half Bridge (NTC)	M0
MB900DA120M0	1200	900	1.80	Half Bridge (NTC)	M0
MG150DA170M0	1700	150	1.58	Half Bridge (NTC)	M0
MG300DA170M0	1700	300	1.65	Half Bridge (NTC)	M0
MG450DA170M0	1700	450	1.65	Half Bridge (NTC)	M0
MG600DA170M0	1700	600	1.72	Half Bridge (NTC)	M0
MB300DA170M0	1700	300	1.65	Half Bridge (NTC)	M0
MB450DA170M0	1700	450	1.65	Half Bridge (NTC)	M0
MB600DA170M0	1700	600	1.72	Half Bridge (NTC)	M0
MB900DA170M0	1700	900	1.81	Half Bridge (NTC)	M0
产品型号 Part Number	Vdss (V)	Rds(on) Tj=25°C (mΩ)	电路拓扑结构 Configuration	封装 Housing	
MC02DA120M0	1200	1.55	Half Bridge (NTC)	M0	
MC03DA120M0	1200	2.30	Half Bridge (NTC)	M0	
MC05DA120M0	1200	4.70	Half Bridge (NTC)	M0	
MC02DA170M0	1700	1.70	Half Bridge (NTC)	M0	
MC05DA170M0	1700	4.60	Half Bridge (NTC)	M0	

外型尺寸图  
Outline Dimension

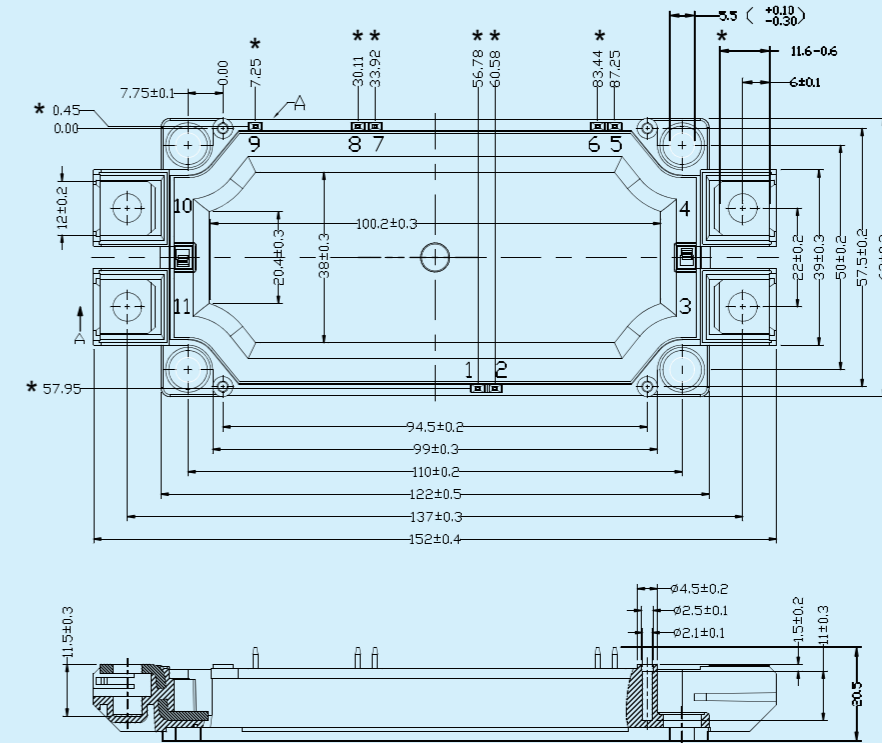

拓扑  
Circuit Diagram

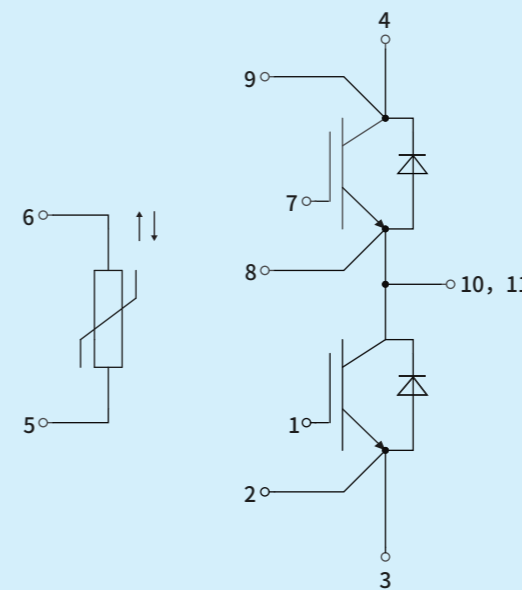

IGBT Series

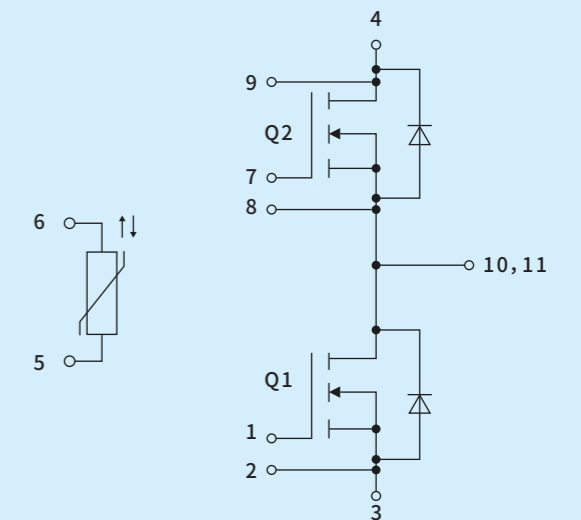

SiC Series

# Hybrid Pack4

## SA系列 (SA series: Sixpack)

额定电压 Rated Voltage: 650V / 1200V  
 电流范围 Current Range: 150A / 200A

## 行业应用 Applications

工业变频器、不间断电源UPS、感应加热、功率电源、  
 电能质量、储能、风力发电、太阳能光伏、轨道交通

Frequency converters, Uninterrupted power supply (UPS),  
 Induction heater, Inverter welder, Power quality solutions,  
 Energy storage, Wind power, PV solar, Rail Transit, etc.



外型尺寸图  
Outline Dimension

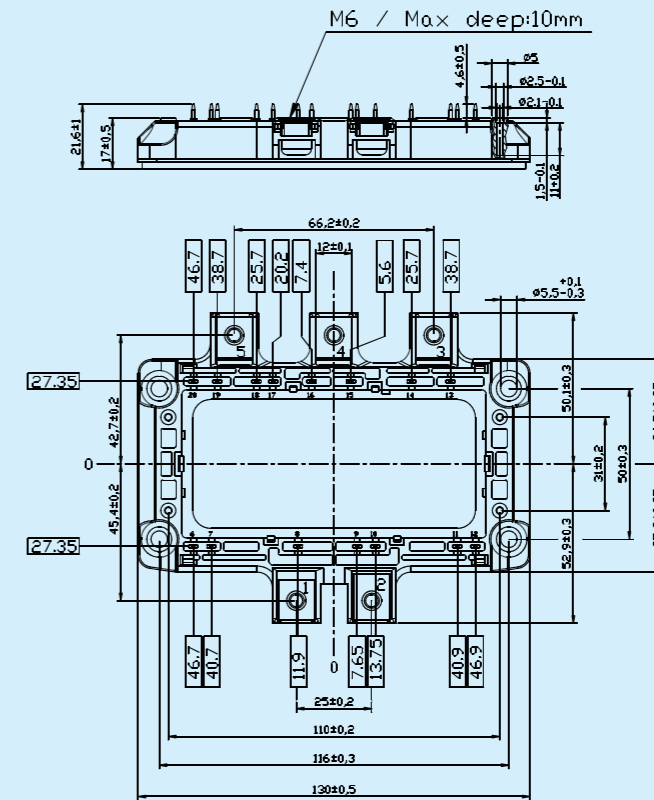

产品型号 Part Number	Vces (V)	Ic (A)	Vce(sat) Tj=25 °C (V)	电路拓扑结构 Configuration	封装 Housing
MG200SA065A2	650	200	1.38	Sixpack	A2
MG150SA120A2	1200	150	1.46	Sixpack	A2
MG200SA120A2	1200	200	1.59	Sixpack	A2

拓扑  
Circuit Diagram

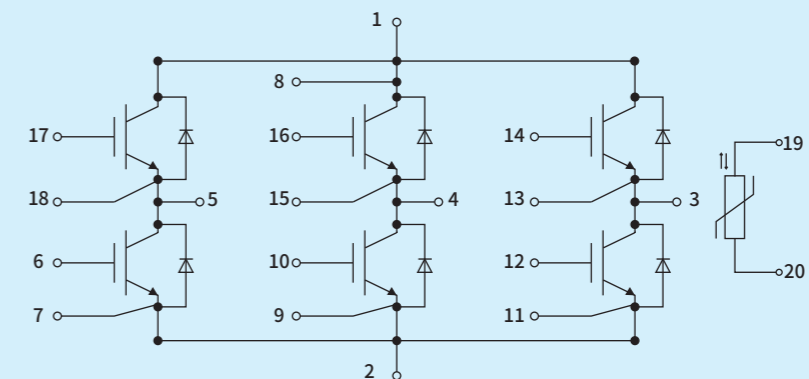

# Hybrid Pack1

## SA系列 (SA series: Sixpack)

额定电压 Rated Voltage: 650V / 750V / 1200V  
 电流范围 Current Range: 200A / 300A / 400A / 550A

## SA系列 碳化硅 (SA series SiC: Sixpack)

额定电压 Rated Voltage: 1200V  
 导通阻抗 Turn-on Resistance: 2.39mΩ

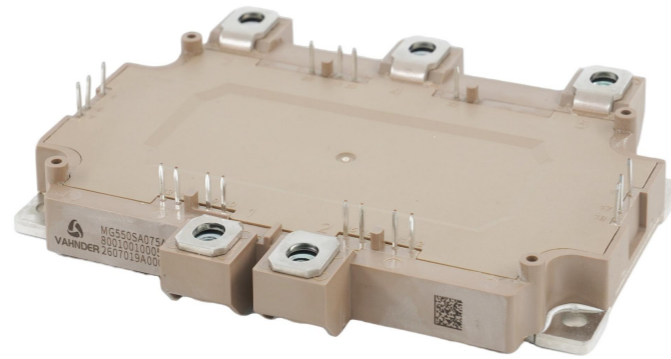

## 行业应用 Applications

工业变频器、不间断电源UPS、感应加热、功率电源、电能质量、储能、风力发电、太阳能光伏、轨道交通

Frequency converters, Uninterrupted power supply (UPS), Induction heater, Inverter welder, Power quality solutions, Energy storage, Wind power, PV solar, Rail Transit, etc.

产品型号 Part Number	Vces (V)	Ic (A)	Vce(sat) Tj=25 °C (V)	电路拓扑结构 Configuration	封装 Housing
MG200SA065A1	650	200	1.37	Sixpack	A1
MG400SA065A1	650	400	1.38	Sixpack	A1
MG550SA075A1	750	550	1.48	Sixpack	A1
MG400SA120A1	1200	400	1.60	Sixpack	A1
产品型号 Part Number	Vdss (V)	Rds(on) Tj=25°C (mΩ)	电路拓扑结构 Configuration	封装 Housing	
MC03SA120A1	1200	2.39	Sixpack	A1	

外型尺寸图  
Outline Dimension

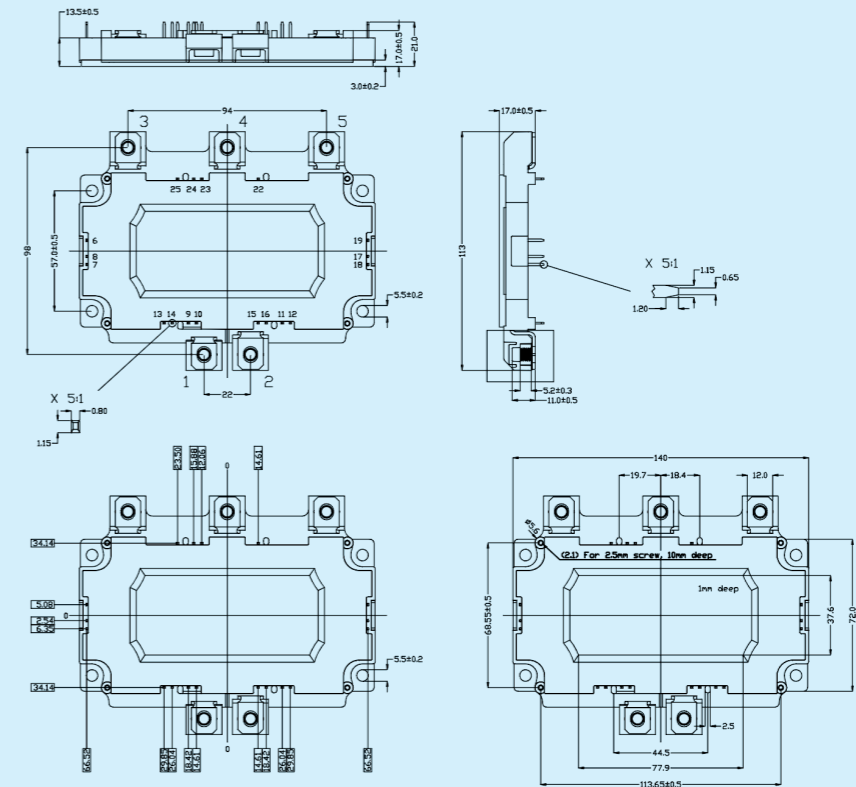

拓扑  
Circuit Diagram

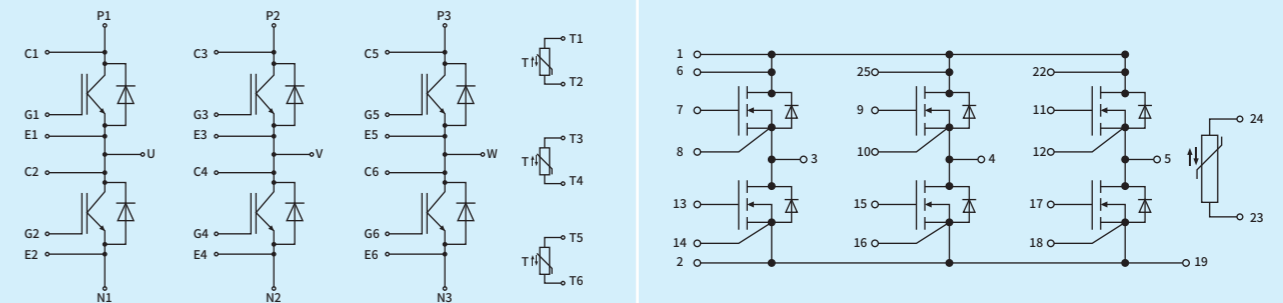

IGBT Series

SiC Series

# Hybrid Pack Drive

## SA系列 (SA series: Sixpack)

额定电压 Rated Voltage: 750V / 1200V  
 电流范围 Current Range: 450A / 550A / 600A / 820A

## SA系列 碳化硅 (SA series SiC: Sixpack)

额定电压 Rated Voltage: 1200V  
 导通阻抗 Turn-on Resistance: 1.75mΩ / 2.50mΩ



## 行业应用 Applications

不间断电源UPS、电能质量、储能、风力发电、太阳能光伏、轨道交通、新能源汽车

Uninterrupted power supply (UPS), Power quality solutions, Energy storage, Wind power, PV solar, Rail Transit, New energy vehicles, etc.

产品型号 Part Number	Vces (V)	Ic (A)	Vce(sat) Tj=25°C (V)	电路拓扑结构 Configuration	封装 Housing
MG550SA075A0	750	550	1.21	Sixpack	A0
MG600SA075A0	750	600	1.20	Sixpack	A0
MG820SA075A0	750	820	1.28	Sixpack	A0
MG450SA120A0	1200	450	1.51	Sixpack	A0
MG600SA120A0	1200	600	1.70	Sixpack	A0
产品型号 Part Number	Vdss (V)	Rds(on) Tj=25°C (mΩ)	电路拓扑结构 Configuration	封装 Housing	
MC02SA120A0	1200	1.75	Sixpack	A0	
MC03SA120A0	1200	2.50	Sixpack	A0	

外型尺寸图  
Outline Dimension

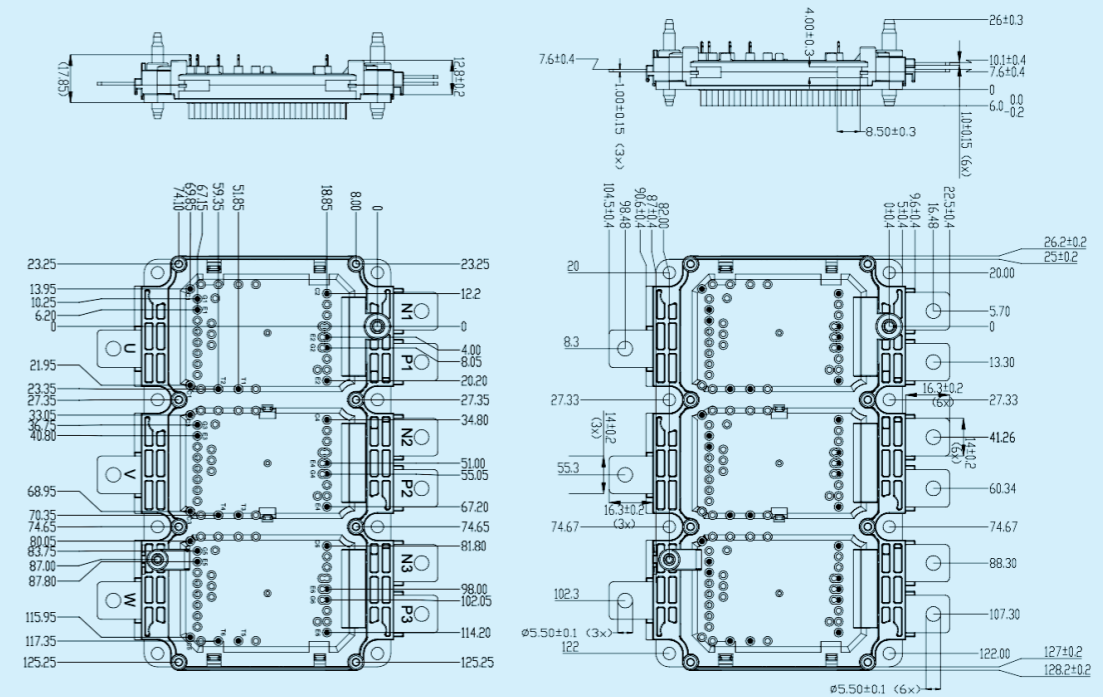

拓扑  
Circuit Diagram

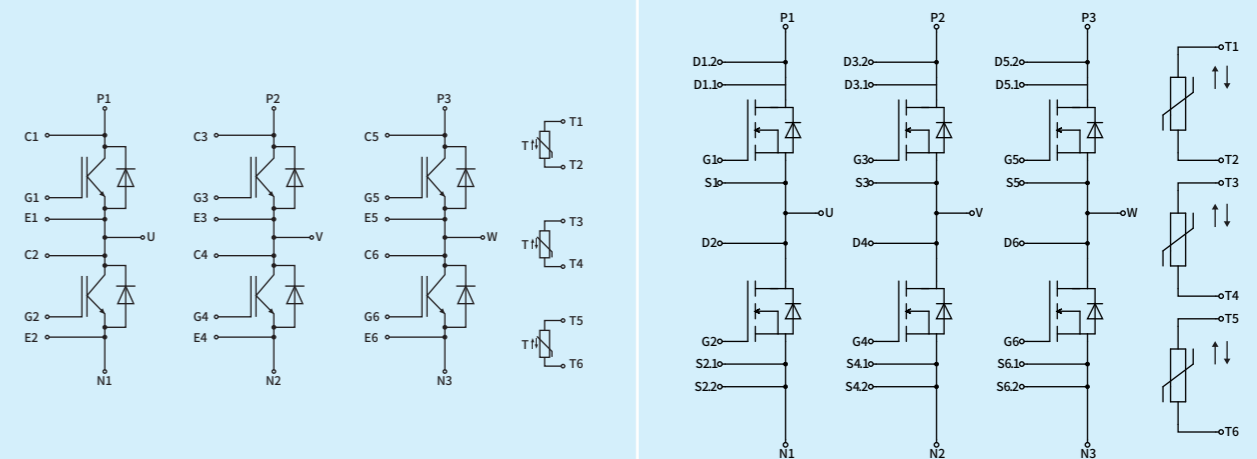

IGBT Series

SiC Series



# EASY 3B

## TL系列 (TL series: 3 Level)

额定电压 Rated Voltage: 1000V  
 电流范围 Current Range: 400A

## DA系列 碳化硅 (DA series SiC: Dual/Half Bridge)

额定电压 Rated Voltage: 1200V  
 导通阻抗 Turn-on Resistance: 5.30mΩ

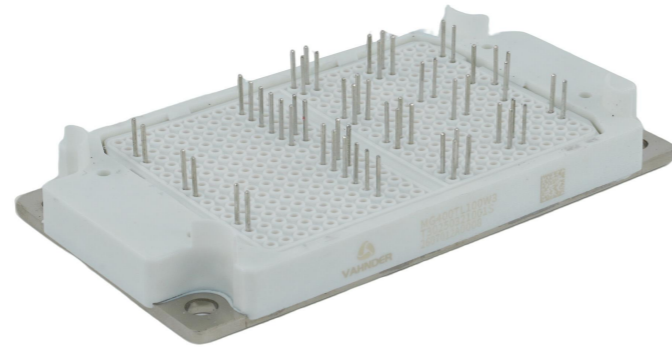

## 行业应用 Applications

高频开关应用、不间断电源UPS、储能、太阳能光伏、新能源汽车  
 High Frequency Switching Application, Uninterrupted power supply (UPS), Energy storage, PV solar, New energy vehicles, etc.

产品型号 Part Number	Vces (V)	Ic (A)	Vce(sat) Tj=25 °C (V)	电路拓扑结构 Configuration	封装 Housing
MG400TL100W3	1000	400	1.60	3 Level	W3
产品型号 Part Number	Vdss (V)	Rds(on) Tj=25°C (mΩ)		电路拓扑结构 Configuration	封装 Housing
MC05DA120W3	1200	5.30		Half Bridge	W3

## 外型尺寸图 Outline Dimension

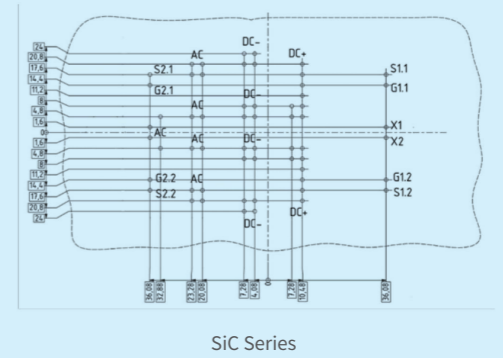
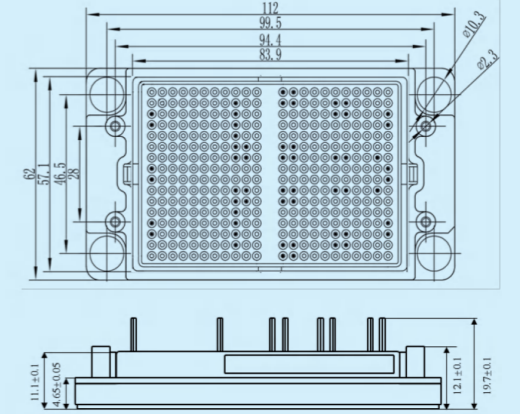
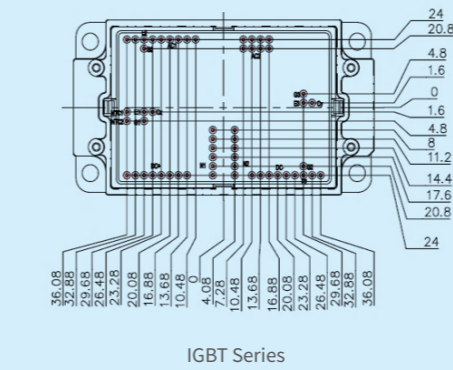
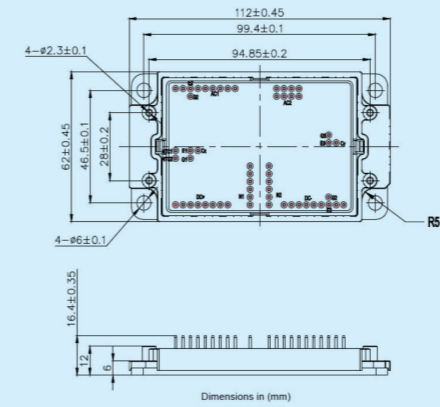

## 拓扑 Circuit Diagram

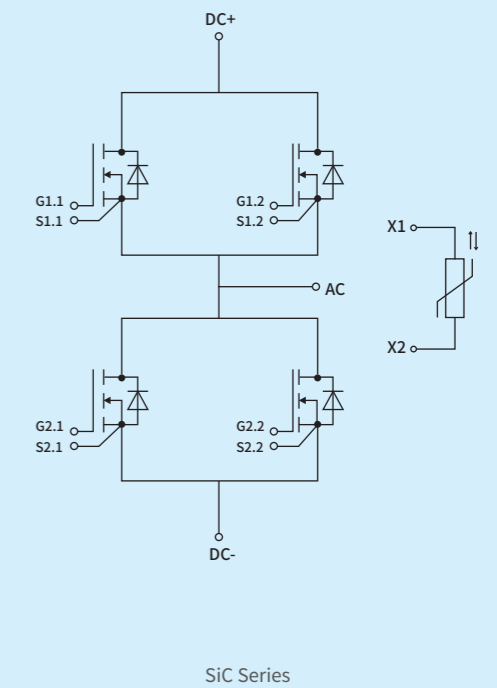
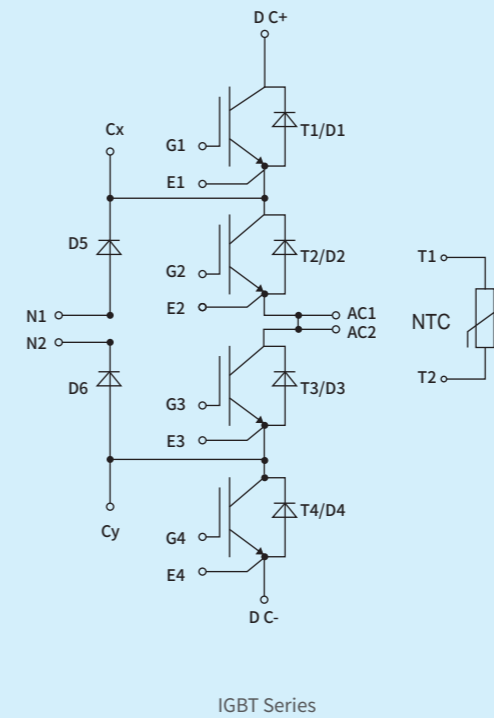

# EASY 4B

## TF系列 (TF series: 3 Level)

额定电压 Rated Voltage: 1000V  
 电流范围 Current Range: 600A

## 行业应用 Applications

辅助逆变器、高功率转换器、电机驱动、风力涡轮机  
 Auxiliary Inverters, High power converters, Motor Drives, wind turbine

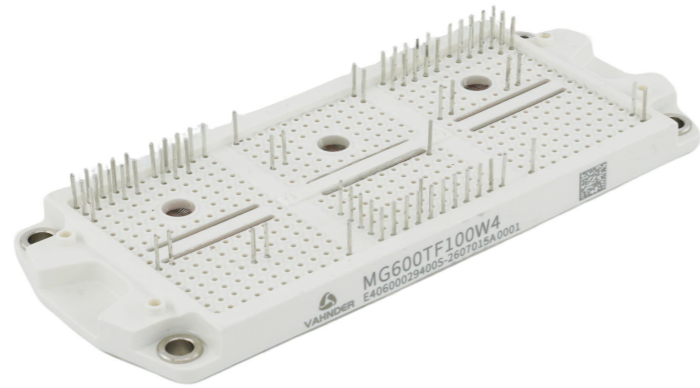

外型尺寸图  
Outline Dimension

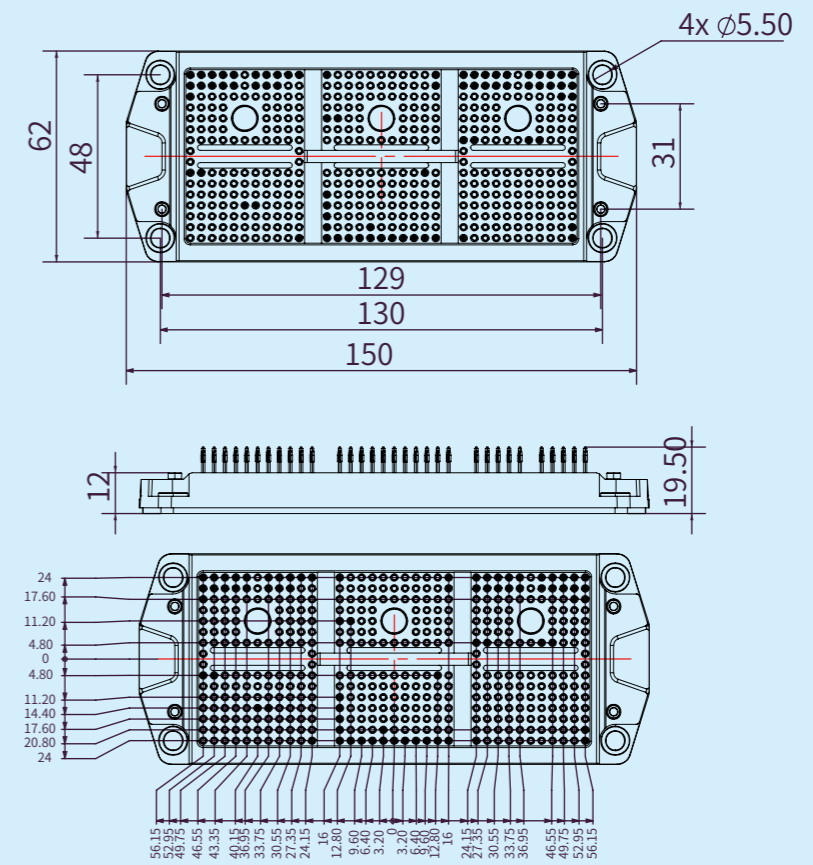

产品型号 Part Number	Vces (V)	Ic (A)	Vce(sat) Tj=25 °C (V)	电路拓扑结构 Configuration	封装 Housing
MG600TF100W4	1000	600	1.60	3 Level	W4

拓扑  
Circuit Diagram

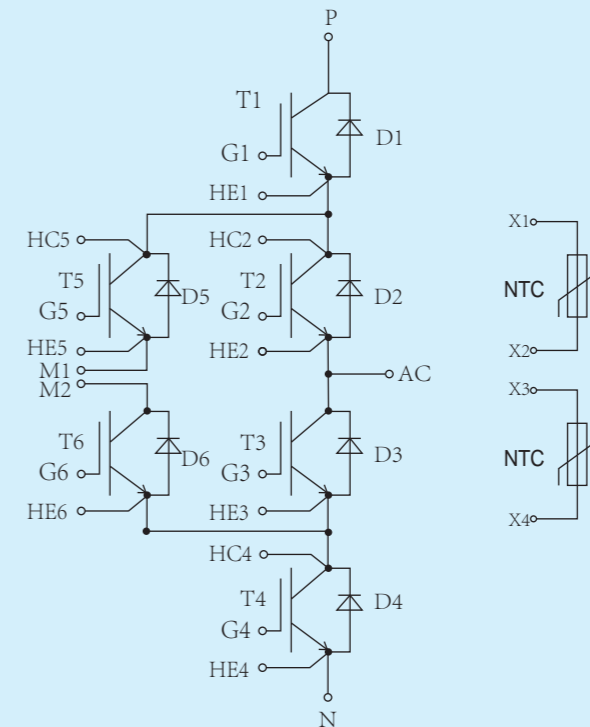

## DA系列 (DA series: Dual/Half Bridge)

额定电压 Rated Voltage: 1700V  
 电流范围 Current Range: 1400A

## 行业应用 Applications

辅助逆变器、高功率转换器、电机驱动、风力涡轮机  
 Auxiliary Inverters, High power converters, Motor Drives, wind turbine.

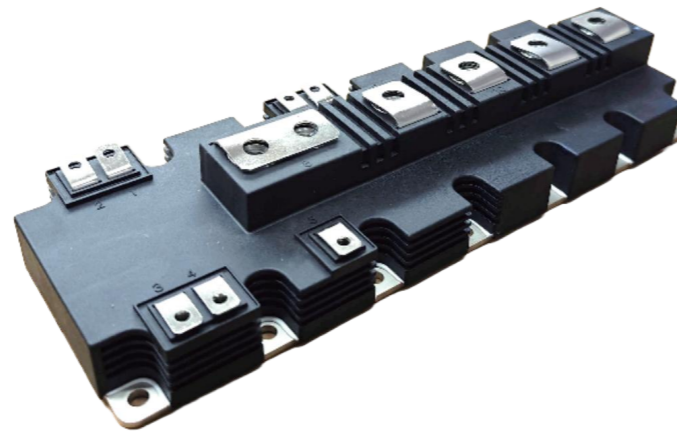

外型尺寸图  
Outline Dimension

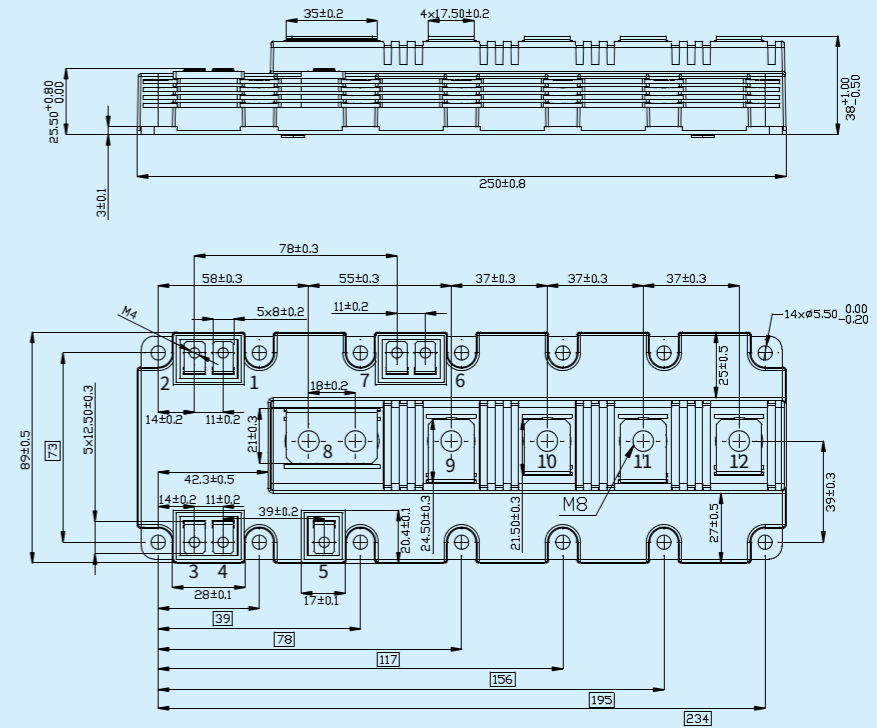

产品型号 Part Number	Vces (V)	Ic (A)	Vce(sat) Tj=25 °C (V)	电路拓扑结构 Configuration	封装 Housing
MG1K4DA170T8	1700	1400	1.65	Half Bridge	T8

拓扑  
Circuit Diagram

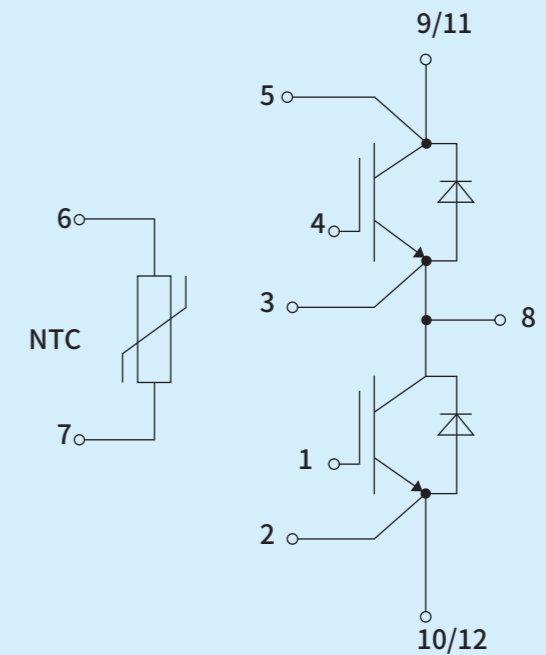

# DISCRETE

## 分立器件 (Discrete Device: Single Switch)

额定电压 Rated Voltage: 650V / 750V / 1200V / 1700V  
 电流范围 Current Range: 10A / 15A / 25A / 40A / 50A / 75A / 100A / 120A  
 导通阻抗 Turn-on Resistance: 6mΩ / 19mΩ / 25mΩ / 30mΩ

## 行业应用 Applications

工业驱动、太阳能光伏、电机驱动、开关电源  
 Industrial Drives, PV solar, Motor Drives, Switch power supplies

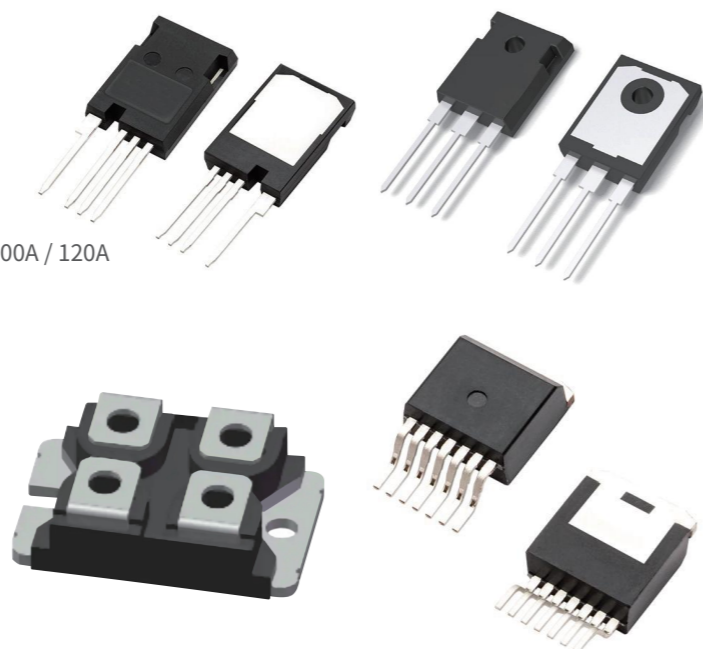

## 外型尺寸图 Outline Dimension

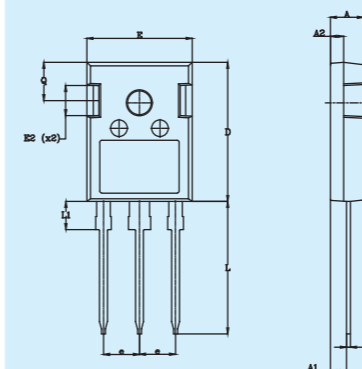

TO 247-3L

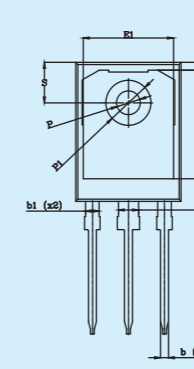

TO 247-4L

产品型号 Part Number	Vces (V)	Ic/Rds (on)	封装类型
MC030ZA065ZA	650	30mΩ	TO 247-4L
MG050ZA120WA	1200	50A	TO 247P-3L
MG075ZA065WA	650	75A	TO 247-3L
MG075ZA065WC	650	75A	TO 247-3L
MC025M075ZC	750	25mΩ	TO 247-4L
MG040M075WC	750	40A	TO 247-3L
MG025ZA120WC	1200	25A	TO 247-3L
MG050ZA120WC	1200	50A	TO 247P-3L
MC019ZA170ZC	1700	19mΩ	TO 247B-4L
MC006ZA120YT	1200	6mΩ	TO 247P-4L
MG050ZA170QT	1700	50A	TO 247P-3L

## 拓扑 Circuit Diagram

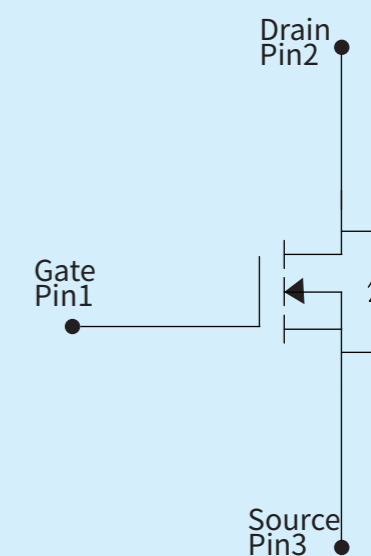
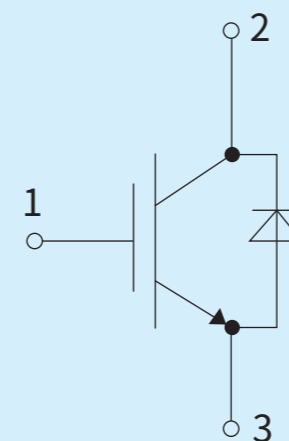

# Intelligent Power Module

## 智能功率模块 (IPM series:3 Phase Bridge)

额定电压 Rated Voltage: 600V/650V

导通阻抗 Turn-on Resistance: 180mΩ / 300mΩ

### 行业应用

冰箱压缩机  
空调压缩机  
小型功率变频器  
伺服驱动器  
电机控制器  
通用逆变器

### Applications

Compressor for the refrigerator  
Compressor for air conditioning  
Small power frequency converters  
servo drive  
motor controls  
purpose inverte

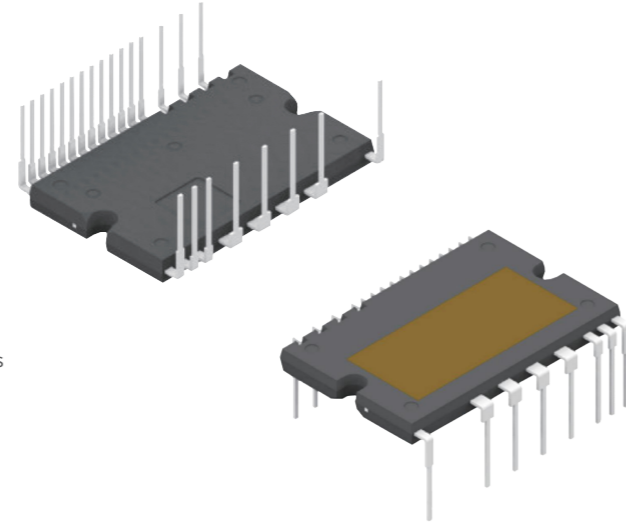

外型尺寸图  
Outline Dimension

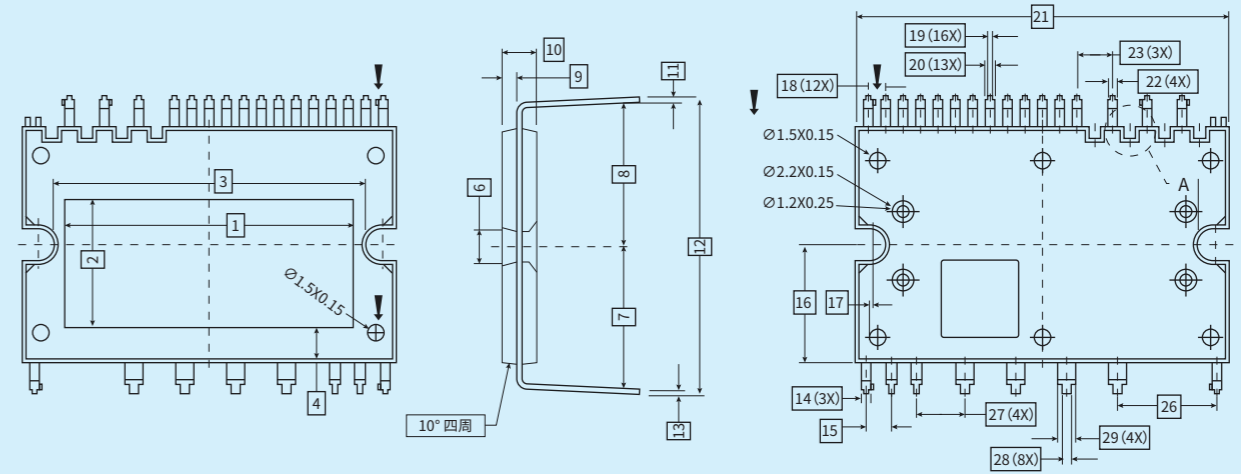

产品型号 Part Number	Vdss (V)	Rds(on) Tc=25°C (mΩ)	电路拓扑结构 Configuration	封装 Housing
IMC300SA060P0	600V	300mΩ	3 Phase Bridge	SOP 23
IMC180SA060P0	600V	180mΩ	3 Phase Bridge	SOP 23

拓扑  
Circuit Diagram

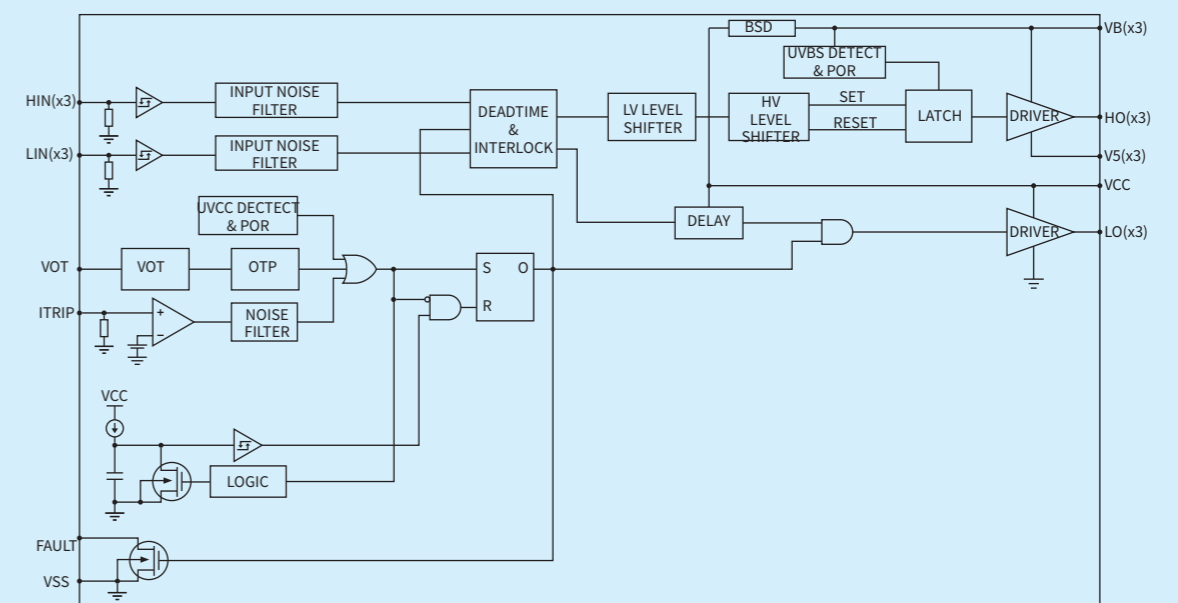

# INTEGRATED

DEVICE MANUFACTURER  
垂直整合制造



# APPLICATION

应用领域



## 新能源

新能源汽车  
(主电驱、OBC、空调、转向等)  
新能源发电  
(光伏逆变器、风电变流器)

## New Energy

New energy vehicles  
(main electric drive, OBC, air conditioning, steering, etc.)  
New energy power generation  
(photovoltaic inverter, wind power converter)



## 工业控制

变频器  
逆变焊机  
不间断电源UPS等

## Industrial Control

Frequency converters,  
Inverter welder,  
UPS, etc.



## 变频白色家电及其他

变频白电  
轨道交通(牵引变流器)  
智能电网等

## Home Appliance and Others

Home appliance  
Rail transit (traction converter)  
Intelligent Power Management (IPM)



# ADVANCED

## LABORATORY

### 先进实验室



设有4大功能试验区:可独立进行17项可靠性测试、失效分析等各类实验室级产品分析及检测试验。

4 functional test areas: 17 reliability tests, failure analysis and other laboratory-scale product analysis and detection tests can be independently carried out.



测试规范完善,具备强大质量监控体系、系统验证能力和经验丰富的专业实验团队。

With perfect test specifications, the Company has a strong quality monitoring system, system verification ability and an experienced professional experimental team.



生产品质管控能力一流,助力高可靠性模块生产,系列产品良品率已达98%。

The production quality control ability is first-class, which helps the production of high-reliability modules, and the yield of series products has reached 98%.



以顾客为导向的应用测试,可及时响应客制产品测试和检测需求,助力客制产品系列化开发。

Customer-oriented application testing can respond to the testing and detection requirements of customized products in time and help the serial development of customized products.

## 四大功能测试区 4 Functional Test Areas

提升产品研发的速度,保证批量产品的高品质和稳定性,提供一流的故障分析及可靠度测试分析服务!

Improve efficiency of R&D, ensure the high quality and stability products, provide first-class test service!

### 生产特性监控 On-line Production Inspection

#### 制程特性

焊接空洞  
打线监控  
成品弯曲等生产全特性监控

#### Production Property

Welding cavity  
Wire bonding monitoring  
Finished product functional test, etc.

#### 动态特性

开关特性  
反向恢复  
电容特性

栅极电荷  
短路测试  
寄生电容

#### Dynamic Property

Switching characteristics  
Reverse recovery  
Capacitance characteristics

Gate charge  
Short circuit test  
Stray capacitance

#### 静态特性

静态参数  
特性曲线

#### Static Property

Static parameters  
Characteristic curves

### 可靠性监控 Reliability Tests

#### 环境可靠性

西门子功率循环  
高温反偏  
高温拉力测试  
高温栅偏  
高温高湿反偏  
震动测试

跌落测试  
温度循环  
冷热冲击  
高低温储存  
高加速老化

#### Environment Reliability

Power cycling  
HTRB  
High temp. ensile test  
HTGB  
H3TRB  
Vibration Test

Drop Test  
TCT  
TST  
HTS & LHS  
HAST

### 失效分析 Failure Analysis

#### 失效分析

3D 轮廓  
RA、RZ粗糙度  
金相显微镜  
EDX元素分析  
机械截面分析  
SAT超声波扫描

2D Xray  
离子无损截面分析  
KEYSIGHT曲线追踪  
SEM扫描

#### Failure Analysis

3D Contour  
RA、RZ Roughness  
Optical Microscope (OM)  
EDX  
AFM  
SAT

2D Xray  
Cross Section Polisher (CP)  
KEYSIGHT technologies  
Scanning Electron Microscopy (SEM)

### 应用测试 Application Test

#### 车载系统

汽车牵引系统  
车载充电系统  
汽车充电桩  
光伏逆变系统  
智能电网逆变系统  
铁路逆变系统





#### Vehicle-mounted Systems

Automobile traction system  
Vehicle-mounted charging system  
Vehicle charging pile  
Photovoltaic inverter system  
Smart grid inverter system  
Railway inverter system



可靠性试验是发现产品潜在的失效机制, 评估产品的失效率, 进而确保产品在正常使用阶段不会出现任何失效机制。

Reliability Test is the process that can identify potential failure mechanisms of product, evaluate its failure rate, and ensure that the product does not exhibit any failure mechanisms during normal use.

### 机械测试 Mechanical Test

测试项目 Test Item	测试目的 Test Purpose	测试标准 Test Standard	测试能力 Test Ability
 振动测试 Vibration	验证机械结构的牢固性和电气连接的稳定性。模拟器件在应用过程中的振动负载, 并验证了器件在出现故障模式(如结构脱落和材料疲劳)时的抗振动能力 Verify the robustness of the mechanical structure and the stability of the electrical connections. The vibration load of the power module during application is simulated and the vibration resistance of the power module is verified in the presence of failure modes such as structural detachment and material fatigue.	IEC 60068 2-6 AEC-Q101 AQG-324	频率范围: 1~3500Hz 最大加速度: 981m/s 可测试X、Y、Z三个方向 Frequency Range: 1~3500Hz Amax: 981m/s X, Y, Z directions test
 机械冲击测试 Shock	验证机械结构的整体性和电气连接的稳定性 Verify the integrity of the mechanical structure and the stability of the electrical connections.	IEC 60068 2-27 AEC-Q101 AQG-324	加速度范围: 0~15000m/s2 脉宽: 0.5~20ms 可测试X、Y、Z三个方向 Acceleration range: 0~15000m/s2 Pulse Width: 0.5~20ms X, Y, Z directions test
 端子强度 Terminal Strength	评估产品端子是否有足够的机械强度 Evaluate whether the product terminals have sufficient mechanical strength.	AEC-Q101 外观无破损、PIN针无脱落 The appearance is not damaged, and the PIN is not falling off.	温度范围: -40~200°C 拉力范围: 0~960N.m Temp. Range: -40~200°C Tension Range: 0~960N.m
 安装强度 Mounting Strength	评估产品在固定力矩下的可靠性 Evaluate the reliability of the product in condition of fixed torque.	外壳完整度、无破裂 Shell integrity, no rupture	扭力范围: 0.2~20N.m Torque Range: 0.2~20N.m
 焊锡性 Solderability	评估产品的可焊性 Evaluate the weldability of the product.	GB/T 2423.28 AEC-Q101	温度范围: 0~350°C Temp. Range: 0~350°C
 焊接耐热性 Resistance to Solder Heat	评估产品PIN针的耐热性 Evaluate the heat resistance of product pins.	GB/T 2423.28 AEC-Q101	温度范围: 0~350°C Temp. Range: 0~350°C

### 环境测试 Environmental Test

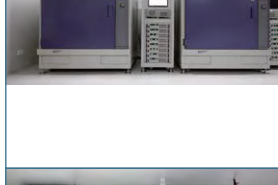
测试项目 Test Item	测试目的 Test Purpose	测试标准 Test Standard	测试能力 Test Ability
 高温存储测试 HTS	评估产品在高温条件下的可靠性及电性性能 Evaluate the reliability and electrical performance of products in condition of high temperature.	IEC 60749-6 AQG-324	温度范围: 60~300 °C Temperature range: 60~300 °C
 低温存储测试 LHS	评估产品在低温条件下的可靠性及电性性能 Evaluate the reliability and electrical performance of products in condition of low temperature.	JESD22-A119 AQG-324	温度范围: -70~150 °C 湿度范围: 20~98% RH Temperature range: -70~150 °C Humidity range: 20~98% RH
 高加速老化测试 HAST	评估产品在环境应力与工作应力条件下的产品寿命及电性性能 Evaluate the lifespan and electrical performance of products in condition of environmental stress and working stress.	IEC 60068-2-66 AEC-Q101	温度范围: 105~142.9°C 湿度范围: 75~100%RH 压力范围: 0.02~0.196MPa Temperature range: 105~142.9°C Humidity range: 75~100%RH Pressure range: 0.02~0.196MPa
 温湿度储存测试 THS	评估产品在恒温恒湿条件下的可靠性及电性性能 Evaluate the reliability and electrical performance of products in condition of constant temperature and humidity.	IEC 60068-2-67	温度范围: -20~180 °C 湿度范围: 10~98% RH Temperature range: -20~180 °C Humidity range: 10~98% RH
 温度循环测试 TCT	用于模拟外界温度变化对产品的影响, 验证器件或模块的整体结构和材料 Used to simulate the impact of external temperature changes on products, verify the overall structure and materials of power devices or modules.	IEC 60749-25 AEC-Q101	温度范围: -70~180 °C 温度变换速率: 26°C/min Temperature range: -70~180 °C Temperature change rate: 26 °C/min
 温度冲击测试 TST	验证IGBT在被动温度变化的情况下对机械应力的抵抗能力 Verify the resistance of IGBT to mechanical stress in condition of passive temperature changes.	IEC 60068-2-14 AQG-324	高温温度范围: 60~205 °C 低温温度范围: -77~0 °C 温度转换阶段时间: 10s High temperature range: 60~205 °C Low temperature range: -77~0 °C Temperature conversion phase time: 10s

### 耐力测试 Endurance Test

测试项目 Test Item	测试目的 Test Purpose	测试标准 Test Standard	测试能力 Test Ability
 高温反偏老化测试 HTRB	主要用于验证长期稳定情况下芯片的漏电流, 考验对象是IGBT边缘结构和钝化层的弱点或退化效应。 Evaluate the leakage current of the power device in condition of high temperature and reverse bias conditions.	IEC 60749-9 AEC-Q101 AQG-324	温度范围: 20~200 °C 电压范围: 0~2000V Temperature range: 20~200 °C Voltage range: 0~2000V
 高温栅反偏老化测试 HTGB	主要用于验证栅极漏电流的稳定性, 考验对象是IGBT栅极氧化层。 Verify the stability of gate leakage current, the test object is the IGBT gate oxide layer.	IEC 60749-9 AEC-Q101 AQG-324	温度范围: 20~200 °C 电压范围: 0~30V Temperature range: 20~200 °C Voltage range: 0~30V
 高温高湿反偏老化测试 H3TRB	又名双85测试, 主要用于测试湿度对功率器件长期特性的影响。 Also known as Double 85 Test, it is mainly used to test the impact of humidity on the long-term characteristics of power devices.	IEC 60749-9 AEC-Q101 AQG-324	温度范围: 20~100 °C 湿度范围: 25~98% RH 电压范围: 0~2000V Temperature range: 20~100 °C Humidity range: 25~98% RH Voltage range: 0~2000V
 功率循环测试 (分钟级) PC / min	评估器件在重复热应力下的可靠性和寿命。(分钟级) Evaluate the reliability and lifespan of the device in condition of repeated thermal stress. (Minute-level)	IEC 60749-34 AEC-Q101 AQG-324	设备输出: 四通道 单通道最大电流600A 最大可输出电流2400A Current output: four channels Single channel maximum current 600A Maximum output current 2400A
 功率循环测试 (秒级) PC / sec	评估器件在重复热应力下的可靠性和寿命。(秒级) Evaluate the reliability and lifespan of the device in condition of repeated thermal stress. (Second-level)	IEC 60749-34 AEC-Q101 AQG-324	设备输出: 四通道 单通道最大电流600A 最大可输出电流1800A Current output: four channels Single channel maximum current 600A Maximum output current 1800A

## 失效分析实验室 Failure Analysis Laboratory

失效分析是为确定和分析失效器件的失效模式、失效机理、失效原因和失效性质而对产品所做的分析和检查。

Failure analysis is the analysis and inspection of a product to determine and analyze the failure mode, failure mechanism, failure cause, and failure property for failed devices.



拥有经验丰富的专业实验团队, 高效的失效分析能力。精湛的样品制备技术, 如切片分析+离子束研磨等。  
Experienced professional experimental team, efficient failure analysis ability.  
Excellent sample preparation techniques, such as Cross Section Polisher + ion beam grinding, etc.



独立失效分析实验室, 具备各类专业仪器设备, 实验规范及制度完善, 贯穿产品生命周期的各个环节。可对材料表面和剖面、材料内部及材料半成品进行微区或其成份元素的全面分析。

Independent failure analysis laboratory, with all kinds of professional instruments and equipments, experimental standards and perfect system, throughout all aspects of the product life cycle. The surface and profile of the material, the interior of the material and the semi-finished product of the material can be fully analyzed in microregion or their component elements.



系统级测试平台, 以全覆盖测试方式, 对设计研发、生产和应用过程中的失效问题进行精细化分析, 可快速有效找到失效具体位置、失效原因及预防措施, 满足用户对高品质高可靠性产品要求。

System-level test platform, with full coverage test method, fine analysis of failure problems during the R&D, production and application process, can quickly and effectively find the failure specific location, failure causes and preventive measures to meet customers' requirements for high-quality and reliable products.

### SEM/EDX

SEM景深大、分辨率高, 放大倍率可达到数十万倍以上, 可用来观察样品表面及剖面微结构; 另配备EDS, 可对样品表面同时进行微区之材料分析, 包括定性、半定量之成分分析以及特定区域之Point、Line Scan、Mapping分析。

SEM has a large depth of field, high resolution, and a magnification of hundreds of thousands of times or more, which can be used to observe the surface and profile microstructure of samples; Equipped with EDS, it can simultaneously perform micro area material analysis on the surface of the sample, including qualitative and semi quantitative component analysis, as well as point, line scan, and mapping analysis for specific areas.

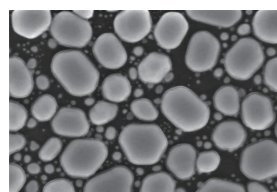

金颗粒的高解析影像  
High resolution images of gold particles

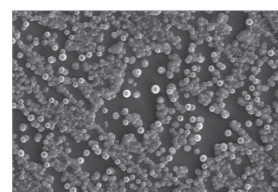

铜颗粒的高解析影像  
High resolution images of copper particles

### 2D X-ray

2D X-ray检测, 是当前非破坏检测产品内部缺陷分析有效且快速的方法, X-ray可检测待测物内部结构及是否有缺陷、空洞(Void)、Crack等异常。

2D X-ray detection is currently an effective and fast method for analyzing internal defects in non-destructive testing products. X-ray can detect the internal structure of the tested object and whether there are defects, voids, cracks, and other abnormalities.

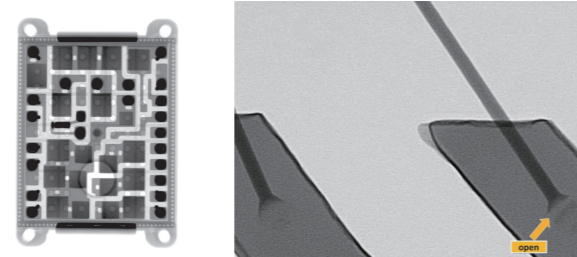

### SAT 超声波扫描

SAT超声波可用来检测芯片组件内部不同位置的脱层(Delamination)、裂缝(Crack)、气洞及粘着状况, 多用于检查芯片封胶内的缺陷。

SAT ultrasound can be used to detect delamination, cracks, air holes, and adhesion at different positions inside chip components, and is often used to inspect defects inside chip seals.

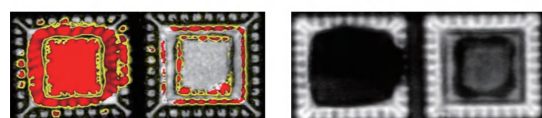
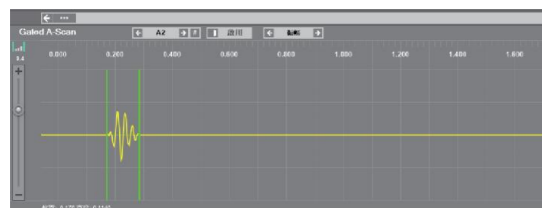

### 切片分析 PCBA (X-section)

快速的样品制备方式之一, 利用砂纸或钻石砂纸, 加上后续的抛光, 可处理出清晰的样品表面。

One of the fast sample preparation methods is to use sandpaper or diamond sandpaper, combined with subsequent polishing, to produce a clear sample surface.

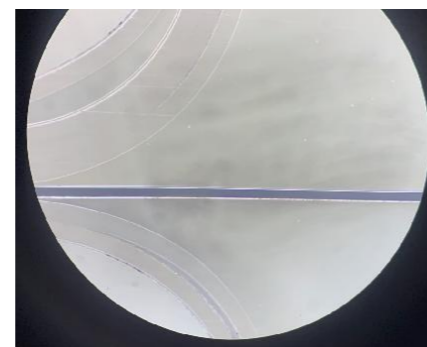

### 离子束研磨 Cross Section Polisher (CP)

离子束剖面研磨、离子束截面研磨(Cross Section Polisher, 简称CP), 是利用离子束切割方式, 去切割出样品的剖面, 不同于一般样品剖面研磨, 离子束切割的方式可避免因研磨过程所产生的应力影响。

Ion beam profile grinding, Cross Section Polisher (referred to as CP), it uses ion beam cutting to cut the profile of a sample. Unlike general sample profile grinding, ion beam cutting can avoid stress effects caused by the grinding process.

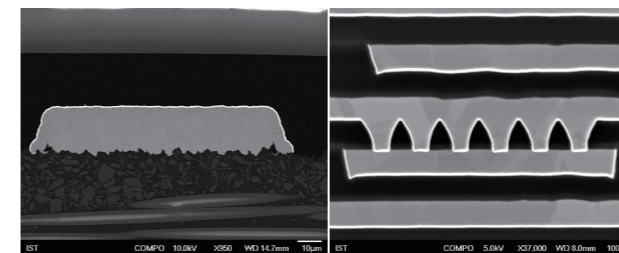

### 双眼显微镜 Optical Microscope (OM)

透过光学的透镜放大、缩小及CCD来撷取影像, 进行表面形貌观察。

Using optical lenses for magnification, reduction, and CCD to capture images and observe surface morphology.

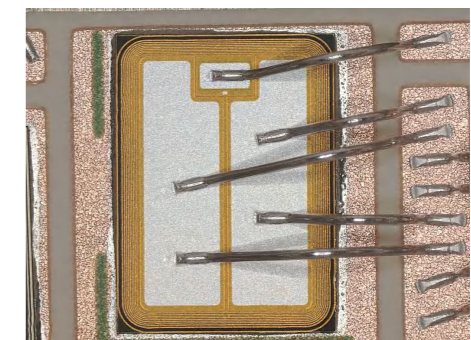

### 红药水渗透 Red Medicine Penetration Test

利用液体具有渗透的特性, 可以渗透到所有的焊锡缝隙来判断焊接是否完好。

By utilizing the permeability of liquids, it can penetrate all solder gaps to determine the integrity of the welding process.

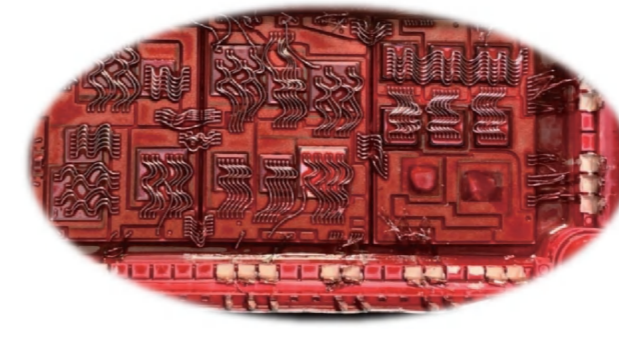

### 弹坑试验 Crater Test

芯片失效分析时, 需分析内部的芯片、打线、组件, 因封装胶体阻挡观察, 利用「laser蚀刻」及「湿式蚀刻」两种搭配使用, 使封装体内包覆的对象裸露出来, 以便后续相关实验处理、观察。

It is necessary to analyze the internal chips, wiring, and components during chip failure analysis. Due to the obstruction of the packaging colloid, two combinations of "laser etching" and "wet etching" are used to expose the objects inside the packaging for subsequent experimental processing and observation.



弹坑前

弹坑后